



Vertical Normal Lab Freeze Dryer

Model YR05190

Instruction Manual

Thank you very much for purchasing our Kalsteins's Vertical Normal Lab Freeze Dryer Model YR05190

Please read the "Operating Instructions" and "Warranty" before operating this unit to assure proper operation. After reading these documents, be sure to store them securely together with the "Warranty" at a hand place for future reference.



Warning: Before operating the unit, be sure to read carefully and fully understand important warnings in the operating instructions.



OUR SERVICES

Benefits and Support

In Kalstein France, we take care of the full satisfaction of our customers, that is why we provide value-added services of the highest level based on our experience.



Online Inductions and Trainings

In any part of the world, receive your induction or training from our specialized team of engineers



Quick Response

Our work team is always available to response all your consults or questions, in order to support you in any situation.



#Letsgivemore

Thanks to your purchase, a donation will be made to a non-profit foundation that fights against breast cancer and helps most vulnerable communities.



Technical Support

Enjoy of personalized advice for the correct preventive and corrective maintenance of your equipment, thanks to Kalstein's manuals and articles, special catalogues and video tutorials.

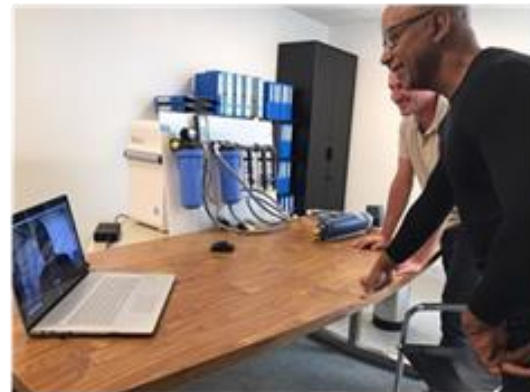

Delivery Logistics

We take care of all the necessary logistics for the dispatch of your goods, whether is by sea, land or air.



Kalstein Worldwide

With more than 25 years growing with our customers, Kalstein's multiformat and modern content, is now present in more than 10 countries and increasing.





■ Safety

The safety statements in this manual comply with the requirements of the HEALTH AND SAFETY AT WORK ACT, 1974.

Read following instructions before installing and using the instrument and its accessories. The apparatus should be operated by appropriate laboratory technicians.

■ General

The apparatus described in this manual is designed to be used by properly trained personnel in a suitable equipped laboratory. For the correct and safe use of this apparatus it is essential that laboratory personnel follow generally accepted safe procedures in addition to the safety precautions called for in this manual.

The covers on this instrument may be removed for servicing. However, the inside of the power supply unit is a hazardous area and its cover should not be removed under any circumstances. There are no serviceable components inside this power supply unit. Please avoid touching the high voltage power supply at all times.

Some of the chemicals used in spectrophotometer are corrosive and/or inflammable and samples may be radioactive, toxic, or potentially infective. Care should be taken to follow the normal laboratory procedures for handling chemicals and samples.

■ Electrical

Before switching on the apparatus, make sure it is set to the voltage of the local power supply.

The power cord shall be inserted in a socket provided with a protective earth contact. The protective action must not be negated by the use of an extension cord without a protective conductor.

■ Warning

Any interruption of the protective conductor inside or outside the apparatus or disconnection of the protective earth terminal is likely to make the apparatus dangerous. Intentional interruption is prohibited.

Whenever it is likely that the protection has been impaired, the apparatus shall be made inoperative and be secured against any unintended operation.

NEVER touch or handle the power supply on due to the high voltage!

The protection is likely to be impaired if, for example, the apparatus

- Shows visible damage
- Fails to perform the intended measurements
- Has been subjected to prolonged storage under unfavorable conditions
- Has been subjected to severe transport stresses

■ Radio Interference

For compliance with the EMC standards referred to in the EC Declaration of Conformity, it is necessary that only shielded cables supplied by us are used when connecting the instrument to computers and accessories.



Contents

Chapter 1 Introduction	1
1.1 Summary	1
1.2 Characteristics and Technical Parameters	1
1.4 Installation and Preparations for Freeze Drying	3
1.5 Installation of Freeze Dryer	5
1.6 Installation Steps:	6
1.6 Test of Freeze Dryer:	6
1.7 Notices:	7
✓ 1 There are no obstructions behind and at sides of host within 30cm;	7
1.8 The General Pre-Freezing Process with Steps:	8
1.9 Drying Process:	8
Chapter 2 Multi-Mainfold Configuration Drying Process	10





Chapter 1 Introduction

1.1 Summary

The vacuum freeze-drying technology, which is also called sublimation drying, is a technical method that freezes the samples in advance, and then sublimates its moisture in the vacuum state. Goods are easier for long-term preservation after freeze-drying processing. They can be restored to the original state and maintain their chemical and biological characteristics after being watered. So the freeze-drying technology is widely used in medicine, food, chemistry industry and biological products etc.

1.2 Characteristics and Technical Parameters

1. Main characteristics

- ✓ SECOP compressor, the refrigeration process is rapid and the condenser temperature is low.
- ✓ LCD screen control system, simple operation and good function.
- ✓ The control system automatically stores data, and data can be viewed in form of curves. Whole freeze-drying process is clear.
- ✓ The drying chamber uses the transparent organic glass drum. So you can clearly view sample state and observe the whole freeze-drying process.
- ✓ The vacuum pump is connected with host by international standard KF quick joint.
- ✓ Performance of machine is stable, easy to operate and low noise.

2. Technical parameter

- ✓ cold trap coil temperature: -50°C (no-load)
- ✓ Limit vacuum: less than 10Pa



1.3 Conditions in Use

- ✓ Ambient temperature in normal working condition: 10°C-26°C.
- ✓ Relative humidity: ≤70%.
- ✓ Power supply: 220V±10%, 50Hz
- ✓ The working environment should be no conductive dust, explosive and corrosive gases and strong electromagnetic interference.

2. Transport and storage conditions

- ✓ Environment temperature: -40°C ~ 50°C.
- ✓ Relative humidity: ≤93%.
- ✓ The storage conditions should be well-ventilated, no corrosive gases.
- ✓ The safety classification: I Grade B Type.





1.4 Installation and Preparations for Freeze Drying

- ✓ Structure of freeze dryer and name of partition

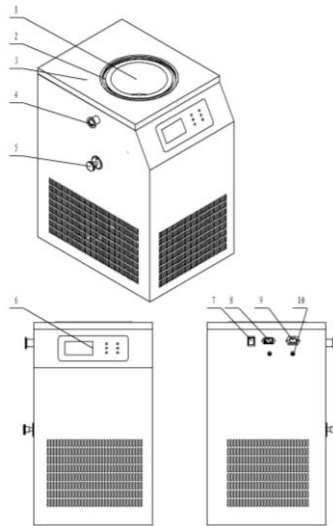

Figure 1-1 Structure of host

- | | | |
|---------------------|---------------------------------|-----------------|
| 1 condenser | 2 sealed ring | 3 workbench |
| 4 vacuum port | 5 drain valve (air inlet valve) | |
| 6 control panel | 7 switch | 8 general power |
| 9 vacuum pump power | | 10 fuse |

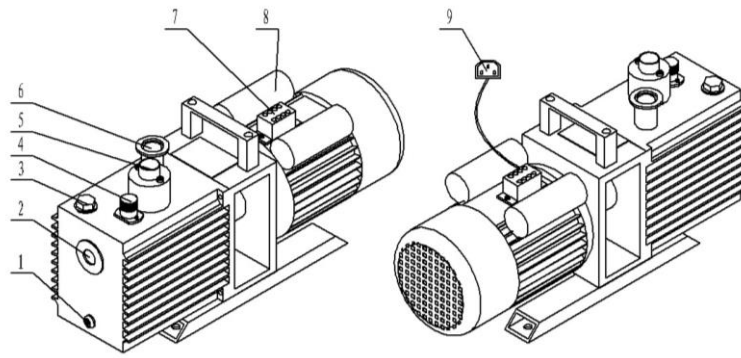

Figure 1-2 structure of vacuum pump

- 1 oil drain 2 oil level glass 3 oil filler hole
- 4 gas ballast valve 5 exhaust port 6 air inlet
- 7 connecting terminal 8 capacitor 9 vacuum pump power cord

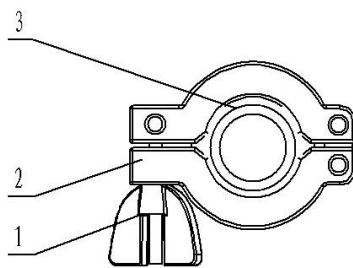

Figure 1-3 structure of clamp

- 1 screw nut 2 support 3 gasket ring

1.5 Installation of Freeze Dryer

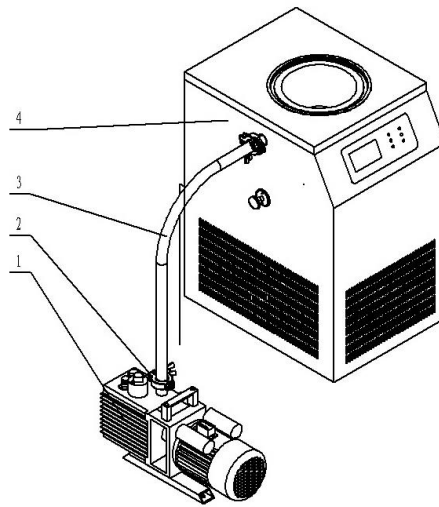

Figure 1-4 connection of the device

1 vacuum pump 2 clamp 3 tube that connects host with vacuum pump 4 host





1.6 Installation Steps:

- ✓ Check accessories complete and undamaged after unpacking box;
- ✓ Add vacuum pump oil to middle of level glass
- ✓ Please use our designated vacuum pump oil.
- ✓ Vacuum pump oil parameter:
- ✓ Coefficient of viscosity: 100; specific gravity: 1 ; flash point: 120 (°C)
- ✓ 40°C kinematic viscosity: 100 (cst) ; pour point: 60 (°C)
- ✓ Connect the air inlet on pump and tube by clamp; the other end of tube connected with vacuum port on host;
- ✓ Connect the “vacuum pump power cord” with “vacuum pump power ”interface on host;
- ✓ One end of the power line is inserted into “general power” interface on host; the other end is connected to power supply 220V, 50Hz (the power should be connected with ground lead).
- ✓ Turn on switch and test the index of freeze dryer (vacuum degree<10Pa, Minimum condenser temperature<-50°C).Then the device is put into use.

1.6 Test of Freeze Dryer:

- ✓ Test of condenser temperature
- ✓ Cover the pre-freeze lid
- ✓ Turn on switch, to enter control system. Touch the screen, to go to main interface. Press “compressor” to turn on compressor to test refrigeration.
- ✓ Condenser temperature drops to -50°C within 30 minutes, test is ok.
- ✓ Test of vacuum degree
- ✓ Press “viscometer” to turn on vacuum gauge, standard atmosphere is displayed;
- ✓ Put on sealed ring
- ✓ tighten the air inlet valve
- ✓ Place organic glass drum, drum bottom full contact with sealed ring.
- ✓ 5) Turn on vacuum pump by touching“vacuum pump”. Vacuum degree rapidly decline.
- ✓ Vacuum degree goes down below 10 Pa within 10 minutes, test is ok.
- ✓ After finishing tests, open air inlet valve on host to inflate host and restore normal pressure. Then the machine is ready for running.

1.7 Notices:

- ✓ 1 There are no obstructions behind and at sides of host within 30cm;
- ✓ 2 Make sure that the vacuum pump oil has been filled before starting up.

Operation of pre-freezing and drying process:

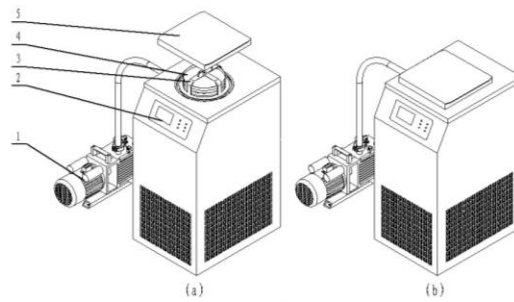

Figure 1-5 pre-freezing process

- 1 vacuum pump 2 control panel 3 pre-freeze shelf
4 material tray 5 pre-freeze lid

1.8 The General Pre-Freezing Process with Steps:

(If you have low-temperature refrigerator, this process may be canceled.)

- ✓ Turn on machine and start compressor. When condenser temperature drops below -40°C , you begin to freeze material ;
- ✓ Put material into tray (liquid directly into tray, solid material and vials evenly put on tray);
- ✓ Put material tray into pre-freeze shelf and put the temperature sensor into material with full touch, to reduce error of sample temperature and actual temperature;
- ✓ Put pre-freeze shelf into condenser;
- ✓ Cover the pre-freeze lid;
- ✓ When temperature of all parts of material drop below eutectic point, this condition will be still keeping about one hour .Then pre-freezing process is over and ready to make drying process.

1.9 Drying Process:

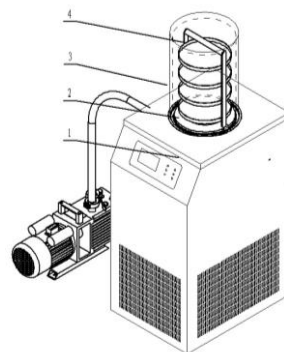

Figure 1-6 ordinary configuration drying process

1 main engine

2 material tray

3 organic glass barrel

4 drying shelf



- ✓ 1 Take out the material from cold trap and put them on drying shelf;
- ✓ 2 Put the drying shelf on cold trap;
- ✓ 3 Check sealed ring and cover the organic glass barrel;
- ✓ 4 Tight the drain valve in clockwise;
- ✓ 5 Open vacuum pump and vacuum gauge. The vacuum degree is decline. It's normal that the vacuum degree is less than 20Pa;
- ✓ 6 Open drain (inlet) valve and then close vacuum pump. Remove organic glass cover and collect material.
- ✓ 7 Close drain (inlet) valve. Open drain (outlet) valve and clean this freeze dryer.
- ✓ 8 When the vacuum pump doesn't work, please cover the exhaust hole.

Notice: a The refrigerator is mustn't turn off in drying process;

- ✓ Drying time and freezing time is different because of differences in material properties.



Chapter 2 Multi-Mainfold Configuration Drying Process

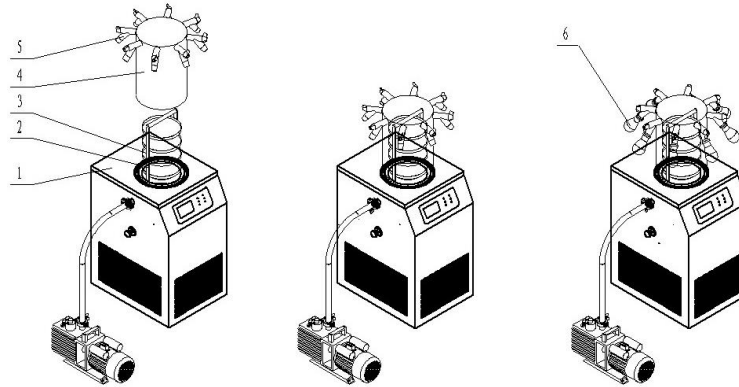

Figure 1-7 Multi-manifold drying process

- ✓ 1 main engine 2 drying shelf 3 material tray
- ✓ 4 multi-manifold organic glass barrel 5 bottle
- ✓ 1 Take out the material from cold trap and put them on drying shelf;
- ✓ 2 Put the drying shelf on cold trap;
- ✓ 3 Check sealed ring and cover the organic glass barrel;
- ✓ 4 Tight the drain valve in clockwise;
- ✓ 5 Open vacuum pump and vacuum gauge. The vacuum degree is decline. It's normal that the vacuum degree is less than 20Pa;
- ✓ 6 Hang the flask one by one and open the manifold valve; when the material in the flask is dry, close the manifold valve and remove the flask.
- ✓ 7 After drying, first open the "drain (inlet) valve" and then close the vacuum pump. Remove the organic glass cover and collect the dry matter.
- ✓ 8 Lose drain (inlet) valve. Open drain (outlet) valve and clean this freeze dryer.
- ✓ 9 When the vacuum pump doesn't work, please cover the exhaust hole.

Notice: a The refrigerator is mustn't turn off in drying process;

- ✓ Drying time and freezing time is different because of differences in material properties.

2.1 Top-Press Configuration Drying Process

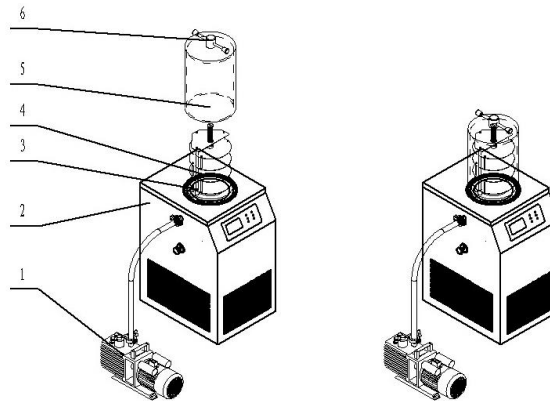

Figure 1-8 top-press configuration drying process

1 vacuum pump 2 main engine 3 top-press drying shelf

4 material tray 5 organic glass barrel 6 handle

- ✓ 1、 Take out the material from cold trap and put them on drying shelf;
- ✓ 2、 Put the drying shelf on cold trap;
- ✓ 3、 Check sealed ring and cover the organic glass barrel;
- ✓ 4、 Tight the drain valve in clockwise;
- ✓ 5、 Open vacuum pump and vacuum gauge. The vacuum degree is decline. It's normal that the vacuum degree is less than 20Pa;
- ✓ 6、 After the drying, first open the drain (inlet) valve and then close the vacuum pump (turn the lid handle clockwise if you need to press the cylinder, then press the cork and let off the air). Remove the organic glass cover and collect the dry matter.
- ✓ 7、 Close drain (inlet) valve. Open drain (outlet) valve and clean this freeze dryer.
- ✓ 8、 When the vacuum pump doesn't work, please cover the exhaust hole.

Notice: a The refrigerator is mustn't turn off in drying process;

B、 Drying time and freezing time is different because of differences in material properties.

2.2 Top-Press Multi-Manifold Configuration Drying Process:

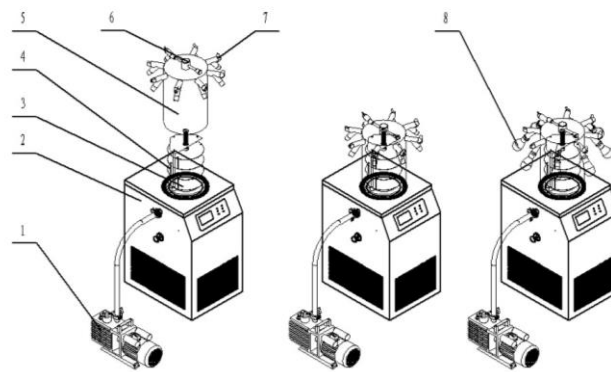

Figure 1-9 Top-press multi-manifold configuration drying process

1 vacuum pump 2 main engine 3 top-press drying shelf

4 material tray 5 top-press multi-manifold organic glass barrel

6 handle 7 multi-manifold interface 8 bottle

- ✓ Take out the material from cold trap and put them on drying shelf;
- ✓ Put the drying shelf on cold trap;
- ✓ Check sealed ring and cover the organic glass barrel;
- ✓ Tight the drain valve in clockwise;
- ✓ Open vacuum pump and vacuum gauge. The vacuum degree is decline. It's normal that the vacuum degree is less than 20Pa;
- ✓ Hang the flask one by one and open the manifold valve; when the material in the flask is dry, close the manifold valve and remove the flask.
- ✓ After the drying, first open the drain (inlet) valve and then close the vacuum pump (turn the lid handle clockwise if you need to press the cylinder, then press the cork and let off the air). Remove the organic glass cover and collect the dry matter.
- ✓ Close power and close drain (inlet) valve. Open drain (outlet) valve and clean this freeze dryer.
- ✓ When the vacuum pump doesn't work, please cover the exhaust hole.

Notice: a. The refrigerator is mustn't turn off in drying process;

- ✓ Drying time and freezing time is different because of differences in material properties.

Note: If material is loaded in vials, turn top press handle clockwise, to seal vial at vacuum state. Then open air inlet valve to inflate host.



2.3 T Type Configuration Drying Process:

- ✓ Install the T-shaped device above the cold trap;
- ✓ The interfaces of the T-type device are connected to ensure sealing;
- ✓ open the vacuum pump (before the "refrigerator" has been opened), when the vacuum value drops to 10-30Pa, you can connect the materials that need to be dried one by one;
- ✓ Remove the dry material;
- ✓ After the drying is finished, first open the water discharge (intake) valve and then close the vacuum pump;
- ✓ Turn off the power, turn off the water release (intake) valve, and defrost the equipment. After the defrosting is finished, open the draining (deflation) valve to drain the device and wipe the equipment clean.
- ✓ When the vacuum pump is not working, please cover the vent hole to prevent dust from entering.



2.4 T Turn off Machine Operation:

- ✓ 1 .Turn off power switch;
- ✓ 2. Unplug the power cord;
- ✓ 3. Clean condenser, drying shelf and acrylic drum and other parts;
- ✓ 4. When the vacuum pump does not work, please cover exhaust port to prevent dust entering.

2.5 T Control System Operation:

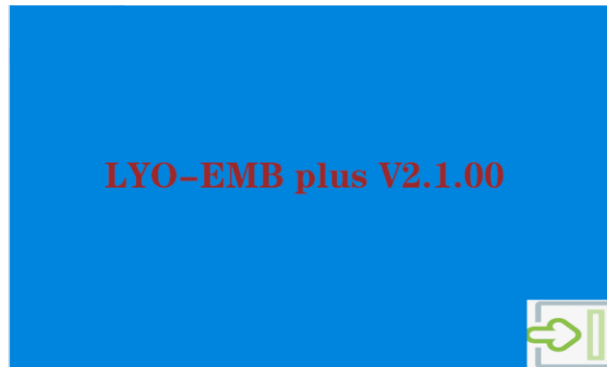

Fig.1 Initial Screen

- ✓ Press the login icon on the lower right corner, the system will switch into the main screen. As shown in Fig.2.

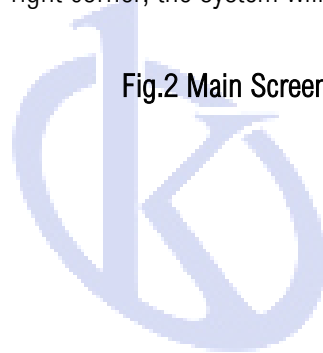
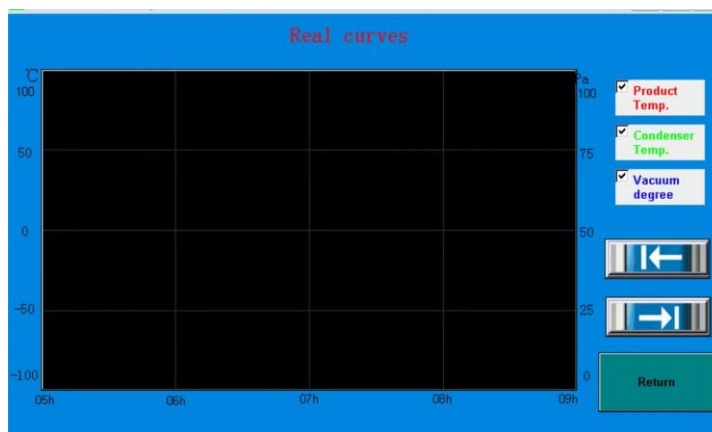
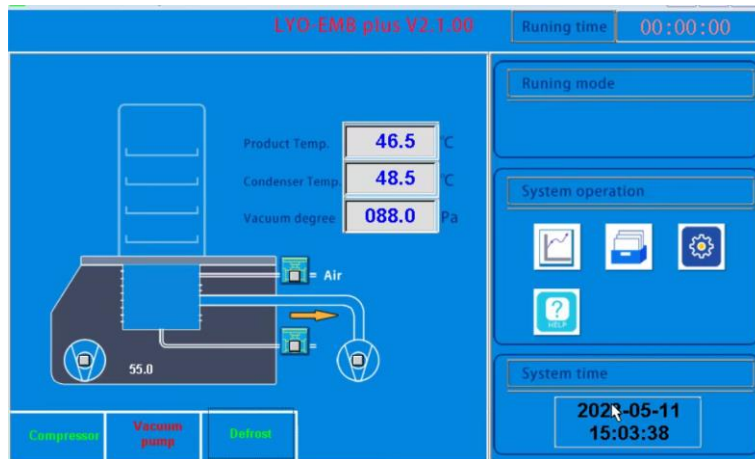

Fig.2 Main Screen





- ✓ On the above screen, you can switch on/off the Compressor, Vacuum Pump and Viscometer through pressing the relevant button. Attention: the compressor is not allowed to start/stop frequently, you need to wait at least 30 seconds to restart the compressor. The vacuum pump can run only when condenser temp is below -40°C (default value). You can also check the product temp, condenser temp, vacuum, and run time of the freeze dryer. Press the Real Curve button, you can check the drying process curve information. As shown in Fig.3.



- ✓
- ✓
- ✓ Press the History Data button on the main screen, you can check the history batch data information. As shown in Fig4.

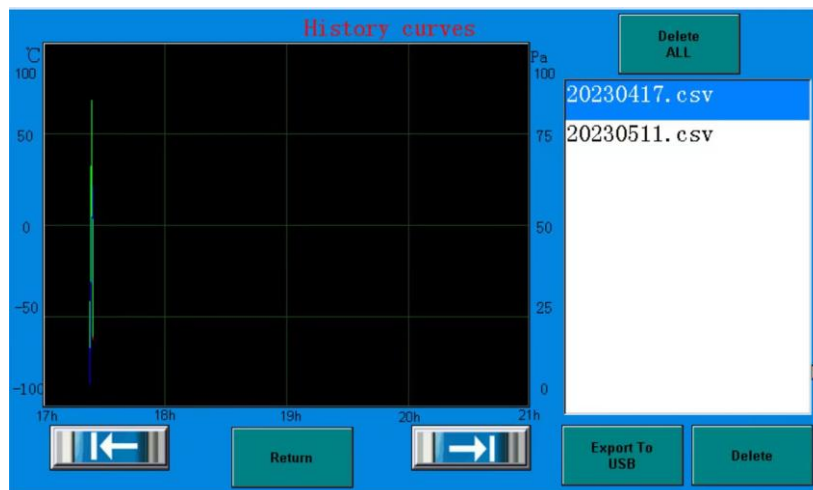



Fig.4 History Data Screen

- ✓ In the above screen, you can select a batch file, then click confirm button to check the history curve information. You can export the selected batch file to you U disk, and also delete the selected batch file.
- ✓ If you need vacuum adjustment, you can press and hold the vacuum
- ✓ Display value area for about 5 seconds to enter the vacuum adjustment setting screen to set parameters.

2.6 T Notices:

- ✓ The vacuum pump should be put on ground so that it maintains a certain height difference with host (at least 50cm), to prevent oil return if power is suddenly off. If power off, you should open air inlet valve to inflate the host, take out the samples as soon as possible and properly store samples
- ✓ Working environment temperature should be less than or equal 32°C. Humidity should be $\leq 80\%$.
- ✓ When turn off the machine, user should inflate host first, later turn off vacuum pump to prevent oil return and sample pollution.
- ✓ The acrylic drum is connected with host by "O" sealed ring.
- ✓ Sealed ring should be kept clean, without organic solvent cleaning; acrylic drum's touch end with sealed ring should be protected from strike and damage.
- ✓ Grounding power socket must be used.
- ✓ The vacuum pump oil should be replaced regularly after working 200 hours continuously.
- ✓ Please don't frequently turn on and turn off power supply and compressor. If compressor stops working because of wrong operation, user needs to restart the compressor after waiting for at least 3 minutes.



2.7 T Common Breakdown and Elimination:

1. The vacuum degree cannot achieve below 15Pa.
 - (1) Check the connection between vacuum pump and host, to make sure clamp is tight.
 - (2) Check whether the bottom of acrylic drum is clean, whether there is damage on the touch surface.
 - (3) Check whether the "O" sealed ring is clean, whether its placement is correct.
 - (4) Check whether the vacuum pump works normally and whether the pump oil is clean.
 - (5) Check whether the air inlet valve is screwed tightly.
2. High condenser temperature

Ambient temperature is too high, leading to bad heat dissipation. Please place the machine in proper environment with well-ventilated condition.

