

YR05108/ YR05109/ YR05110
Ultra-Low Temperature Freezer

Instruction Manual

Thank you very much for purchasing our Ultra Low Temperature Upright Freezer Digital Display.

Please read the "Operating Instructions" and "Warranty" before operating this unit to assure proper operation. After reading these documents, be sure to store them securely together with the "Warranty" at a hand place for future reference.



Warning: Before operating the unit, be sure to read carefully and fully understand important warnings in the operating instructions.



OUR SERVICES

Benefits and Support

In Kalstein France, we take care of the full satisfaction of our customers, that is why we provide value-added services of the highest level based on our experience.



Online Inductions and Trainings

In any part of the world, receive your induction or training from our specialized team of engineers



Quick Response

Our work team is always available to response all your consults or questions, in order to support you in any situation.



#Letsgivemore ♥

Thanks to your purchase, a donation will be made to a non-profit foundation that fights against breast cancer and helps most vulnerable communities.



Technical Support

Enjoy of personalized advice for the correct preventive and corrective maintenance of your equipment, thanks to Kalstein's manuals and articles, special catalogues and video tutorials.



Delivery Logistics

We take care of all the necessary logistics for the dispatch of your goods, whether is by sea, land or air.



Kalstein Worldwide

With more than 25 years growing with our customers, Kalstein's multiformat and modern content, is now present in more than 10 countries and increasing.





Name and model

Ultra Low Temperature Upright Freezer Digital Display - YR05108/ YR05109/
YR05110

Use

Kalstein's Ultra Low Temperature Upright Freezer Digital Display is specially designed and manufactured for long term storage of various biological products, including viruses, germs, erythrocytes, leucocytes and cutis.

Preface

- Please read the Operation Manual carefully before operation for your safety.
- We do not guarantee any safety if the appliance is used for any objects other than intended use or used by any procedures other than those mentioned in this manual.
- Please keep the Operation Manual at an approachable place.
- The contents of the manual will be subjected to change without notice due to the improvement of performance or functions.
- Please contact the sales representative or agency of us if you have any question of this operation manual.
- For any damage to the instrument the user is not required under this manual caused by, or individuals not in accordance with "Safety Tips" requires in the manual caused the damage, our company has no obligation and



responsibility turbot responsible.

- Proper use of protective equipment (including clothing, gloves, goggles, etc.)
- Adopt good health habits, in strict accordance with the product instructions.
- Everyone has an obligation to be responsible for their own safety.
- Not Allowed direct contact with patients, use or affect the product and in the product storage items.
- Products without sterilization.
- The product is used only for storage, not during use with other materials, Organization and Technology in combination.
- Products can not be used to measure or analysis.
- Life and storage life of the products is irrelevant.
- Some models need to regularly add supplies, such as printer paper, test tubes, etc.
- This product is non-explosion-proof products.
- Non flash freeze equipment, is limited to keeping the temperature used.
- Equipment maintenance can only be used by our company or authorized agents to complete.
- Date of manufacture see bar code, Bar code first and second representatives year, third or fourth representative batches, fifth or sixth, seventh or eighth representative product number last month of two representatives.
- Service life: According to affect key components of the shortest life **expectancy.**



Precautions for Safe Operation

- It is imperative that the user complies with this manual as it contains important safety advice.
- Items and procedures are described so that you can use this appliance correctly and safely.
- If the precautions advised are followed, this will prevent possible injury to the user and any other person.

Warning

Failure to observe WARNING signs could result in a hazard to personnel possibly resulting in serious injury or death.

Caution

Failure to observe CAUTION signs could result in injury to personnel and damage to the appliance and associated property.

Meaning of following Marks:

 This mark means Caution.

 This mark means Forbidden.



 This mark means that the regulations must be obeyed.

Be sure keep this Operation Manual at an approachable place.

< Mark on the Appliance >

This label is on the cover in which the electrical components of high voltage are enclosed to prevent the electric shock. The cover should be removed by a qualified engineer or a service personnel only

Meaning of following Marks:







-  This mark means Caution.
-  This mark means Forbidden.
-  This mark means that the regulations must be obeyed.

Be sure keep this Operation Manual at an approachable place.

 **< Mark on the Appliance >**

This label is on the cover in which the electrical components of high voltage are enclosed to prevent the electric shock. The cover should be removed by a qualified engineer or a service personnel only

 **Warning**

-  Do not use the appliance outdoors. Current leakage or electric shock may result if the appliance is exposed to rainwater.
-  This appliance should only be installed by qualified engineers or service personnel. The installation by unqualified personnel may cause electric shock or fire.
-  The appliance should be installed on the solid floor with suitable measures to avoid overturning. Otherwise, it may cause the appliance overturn or physical injury.
-  Never install the appliance in a humid place or a place where it is likely to be splashed by water. Deterioration of the insulation may result which could cause current leakage or electric shock.
-  Do not install the appliance in the place with flammable and explosive materials. Otherwise, it may cause explosion or fire.
-  Do not install the appliance in the place with acid or corrosive gas. Otherwise, it may cause leakage or electric shock as a result of corrosion.



- ⊕ Always ground (earth) the appliance to prevent electric shock. If the power supply outlet is not grounded, it will be necessary to install a ground by qualified engineers.
- ⊘ Do not connect this appliance with the ground through gas pipe, water pipe, telephone wire or lightning rod. Such grounding may cause electric shock in the case of an incomplete circuit.
- ❗ Connect the appliance to a power source as indicated on the rating label attached to the appliance. Use of any other voltage or frequency other than that on the rating label may cause fire or electric shock.
- ⊘ Do not insert metal objects such as a pin or a wire into any vent, gap or any outlet on the appliance. This may cause electric shock or injury by accidental connection with moving parts.
- ❗ Please use this appliance in a safe area when it is used to store toxic, harmful or radioactive materials, incorrect use may cause harm to the health of people and the environment.
- ❗ Turn off the power switch (if provided) and disconnect the power supply to the appliance prior to any repair or maintenance. In order to prevent electric shock or injury .
- ⊘ Please do not touch any electric part or switch with a wet hand. This possibly cause electric shock.

 **Warning**



- ❗ Ensure you do not inhale medicine or suspended particles around the appliance. Otherwise, it may cause harm to your health.
- ⊘ Do not splash liquid onto the appliance directly. Otherwise, it may cause electric shock or short circuit.
- ⊘ Please do not put the container with liquid on the appliance. Otherwise, it may cause electric shock or short circuit.
- ⊘ Do not pull, unwind or bind the power cord, do not damage the plug, since the damaged power cord or plug may cause fire or electric shock.
- ⊘ Please do not use power cord with a loose plug, it may cause fire or electric shock.
- ⊘ Please do not disassemble, repair or refit this appliance without permission since improper operation may cause fire or physical injury.
- ⊘ This appliance can be used by children aged from 8 years and above and persons with reduced physical, sensory or mental capabilities or lack of experience and knowledge if they have been given supervision or instruction concerning use of the appliance in a safe way and understand the hazards involved. Children shall not play with the appliance. Cleaning and user maintenance shall not be made by children without supervision.
- ⊘ If the supply cord is damaged, it must be replaced by the manufacturer, its service agent or similarly qualified persons in order to avoid a hazard.
- ⊘ Do not store explosive substances such as aerosol cans with a flammable propellant in this appliance.



- ❗ Cut off power supply plug if something wrong with the appliance. Continued abnormal operation may cause electric shock or fire.
- ❗ When removing the plug from the power supply outlet, grip the power supply plug, not the cord. Pulling the cord may result in electric shock or fire by short circuit.
- ❗ Disconnect plug and keep the power cord intact before moving the appliance. A damaged power cord may cause electric shock or fire.
- ❗ Disconnect the power plug when the appliance is not used for long period. Keeping the connection may cause electric shock, current leakage, or fire due to the deterioration of insulation.
- ❗ Keep children away from the appliance and keep the door open when the appliance is kept in an unsupervised area.
- ❗ The disposal of the appliance should be accomplished by appropriate person. Remove doors to prevent accidents such as suffocation.
- ⊘ Keep the packing plastic bag away from children because plastic bag may cause suffocation.

 **Caution**

- ❗ Use a dedicated power source as indicated on the rating label attached to the appliance ,Or it may cause fire resulting from abnormal heating.
- ❗ Connect the power supply plug to the power source firmly after removing the dust on the plug. A dusty plug or improper insertion may cause a heat or ignition.
- ⊘ Never store corrosive substances such as acid or alkali in the appliance if the

container can't be sealed. These may cause corrosion of inner components or electric parts.

❗ Check the setting when starting up of operation after power failure or turning off of power switch. The stored items may be damaged due to the change of setting.

❗ Be careful not to tip over the appliance during movement to prevent damage or injury.

Ambient Conditions

- Indoor Use.
- The elevation shall not exceed to 2000m.
- Ambient temperature: 10°C-32°C.
- Maximum relative humidity 80% for temperature up to 32°C, decreasing linearly to 70% relative humidity at 35°C.
- The voltage fluctuation range shall not exceed $\pm 10\%$ of the rated voltage.
- Transient over voltage according to Installation Categories (Over voltage Categories) II. For mains supply the minimum and normal category is II.
- Pollution degree 2 in accordance with IEC 60664.

Components

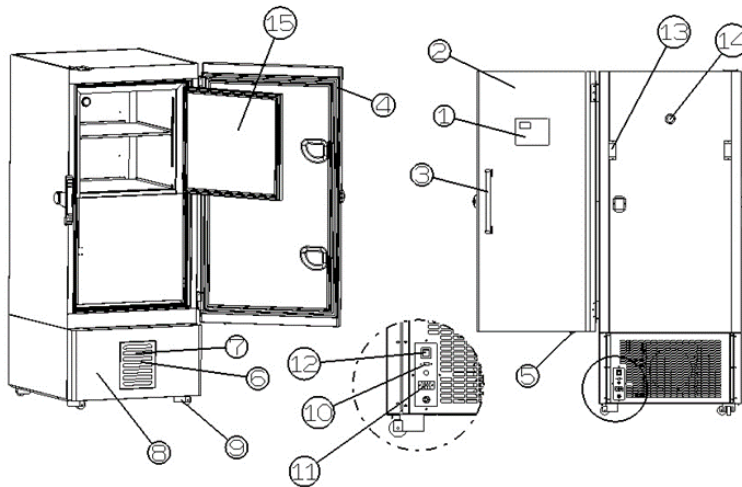

- 1. **Control panel** (on the wall of the external door): display the temperature setting and indication of operating status.
- 2. **External door**: to open the door, grip the handle. When closing the door, please completely lock the external door handle.
- 3. **Handle**: hold the handle to open and close the external door.
- 4. **Magnetic door gasket**: this provides a tight door seal and prevents cold air leak, please keep it clean.
- 5. **Door switch**: detect the status of the external door (Open/Close).
- 6. **Air intake vent grille**: do not block it to keep proper cooling performance.
- 7. **Condensing filter** (behind the grille): the filter can protect the condenser from dust. The dusty filter may cause damage for the refrigerating appliance. Clean the filter monthly.
- 8. **Front panel of device**
- 9. **Caster**: the height of the freezer can be adjusted by this screw type foot. Keep the appliance horizontal during installation. Make sure the rubber part of the casters contact the floor.
- 10. **USB port**: for data download of recent 10000 temperature records.

- 11. **Remote alarm terminal:** it is used for sending the alarm to the remote location.
- 12. **Power switch:** turn ON/OFF the power supply. Power ON: “1”, Power OFF: “0”.
- 13. **Fixed handle** (at the back side): 2 fixed handles are used for keeping the gap between the appliance and the wall.
- 14. **Access port** (at the rear and bottom): this is used for leading a cable and sensor of a measuring appliance, or nozzle of back-up system to indoor.
- 15. **Inner door:** the operation of the inner door should be quick to minimize the temperature rise indoor. Lock the door latch completely when the door is closed. The door is removable for cleaning or defrosting. See page 12 “Routine maintenance”.

Control Panel

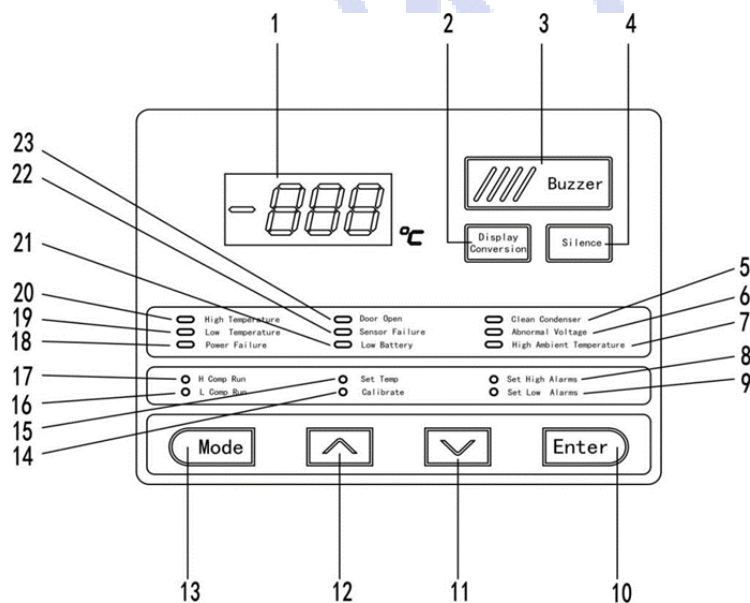

- 1. **Digital Temperature Display:** display the current temperature in the cabinet when it works normally.
- 2. **Button of display switch:** press this button for 1s could display every sensor's temperature and current voltage when it works normally, press again to return



to normal status. In the parameter setting menu, press it to exit the setting menu.

- 3. **Buzzer**
- 4. **MUTE button:** press this button for quit alarm. (Only stops the sound of the alarm. If the fault is not removed, the buzzer will alarm again)
- 5. **Condenser alarm lamp:** when there's too much dust on the condensing filter, the lamp lighted, clean the filter immediately.
- 6. **Abnormal voltage alarm:** the lamp lighted when the input voltage exceeds $220V \pm 10\%$.
- 7. **Ambient temperature alarm:** when the ambient temperature exceeds 32°C , the lamp lighted, when the ambient temperature exceeds 35°C , the lamp lighted and the buzzer sound.
- 8. **High-temperature alarm setting:** set the high-temperature alarm, the lamp lighted.
- 9. **Low-temperature alarm setting:** set the low-temperature alarm, the lamp lighted.
- 10. **Enter button:** set parameters, this button works as Confirm and Save.
- 11. **Value - button (V):** press this button to decrease the value.
- 12. **Value + button (Λ):** press this button to increase the value.
- 13. **Mode button:** press this button to switch mode.
- 14. **Sensor calibrating and setting:** when calibrating the temperature of sensor, the lamp lighted.
- 15. **Temperature setting:** when setting the temperature in the cabinet, the lamp lighted.
- 16. **II Compressor:** when II compressor is running, the lamp lighted.
- 17. **I compressor:** when I compressor is running, the lamp lighted.
- 18. **Power failure alarm:** the lamp lighted when the power supply cut off.



- 19. **Low-temperature alarm:** when the temperature in the cabinet is lower than the set value for a while, the indicating lamp lighted.
- 20. **High-temperature alarm:** when the temperature in the cabinet is higher than the set value for a while, the indicating lamp lighted.
- 21. **Battery capacity alarm:** when the battery capacity is too low, the indicating lamp lighted.
- 22. **Sensor failure alarm:** when the sensor is in short circuit or open circuit, the indicating lamp lighted.
- 23. **Door alarm:** when the door leaves open for a while, the indicating lamp lighted.

Installation Site

To operate this appliance properly and to obtain maximum performance, install the appliance in a location with the following conditions:

a. A place without direct sunlight

It may cause cooling failure if it is installed in the place with direct sunlight.

b. A place with adequate ventilation

Leave at least 10cm space around the appliance for ventilation. Poor ventilation may not obtain intended performance.

c. Keep away from heat sources

Avoid installing the appliance near heat-emitting appliances such as a heater or a boiler etc. Heat can decrease the intended performance of the appliance.

d. A place with firm and level floor.

 **Warning**

- Install the appliance on a strong floor. If the floor is not strong enough or the installation site is not adequate, this may caused injury from the appliance falling or overturning.
- Select a level and strong floor for installation. This precaution will prevent the appliance from falling or overturning.
- Improper installation may caused water spillage or injury.

A place without high humidity

 **Warning**

- Do not use the appliance outdoors. Current leakage or electric shock may caused if the appliance is exposed to rainwater.
- Never install the appliance in a humid place or a place where it is likely to be splashed by water.
- Deterioration of the insulation may cause current leakage or electric shock.

A place without flammable or corrosive gas.

 **Warning**

Never install the appliance in a flammable or volatile location. This may cause explosion or fire or may cause leakage or electric shock by the corrosion of the electrical components

Installation

1 Remove packing materials and packing tapes

Remove all packing materials and packing tapes. Open the door to ventilate the appliance. If the outside panels are dirty, clean them with soft fabric plus diluted neutral detergent.

(Undiluted detergent can damage the plastic components. For the dilution, refer to the instruction of the detergent). After the cleaning with the diluted detergent, always wipe it off with a wet cloth. Then wipe off the panels with a dry cloth.

2 Adjust the level feet

Turn the level feet clockwise to extrude the level feet, so as to contact the floor.

Make sure to keep the appliance at horizontal status.

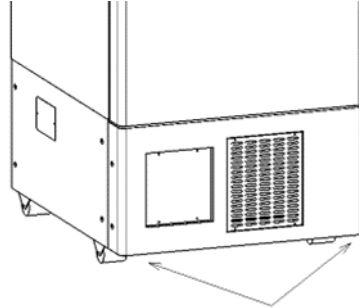

3 Fixed appliance

Two fixed handles are installed at the back panel of the cabinet. Fix the cabinet on the wall with fixed handle and rope or chain.

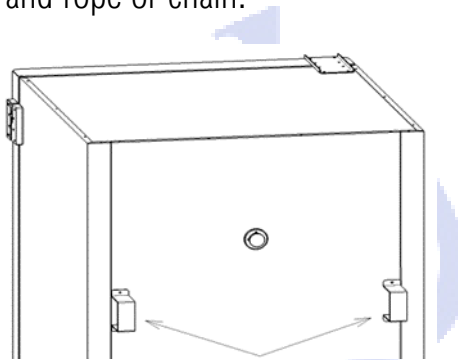

Fixed handle

Warning

- Use a power supply outlet with ground (earth) to prevent electric shock. If the power supply outlet is not grounded, it is necessary to install a ground by qualified engineers.
- Never ground the appliance through a gas pipe, water supply pipe, telephone line or lightning rod. Such grounding may cause electric shock in the case of an incomplete circuit.

Start-up of Appliance

Follow the procedures for the test and formal operations of the appliance:



- 1. Connect the power cord to the dedicated socket having appropriate rating and then turn on the power switch.
- 2. Press the MUTE button to stop the alarm if the alarm sounds.
- 3. Set the storage temperature as needed.
- 4. Check the temperature in the cabinet if reached the setting temperature.
- 5. After confirmed the above, put a small amount of pre-cold articles (-40°C) into appliance to prevent temperature and the time interval at least 2 hours.

Thermostat Setting

The default parameter of thermostat has been set before delivery, do not modify it.

⚠Caution: The default setting of temperature -80°C.

Remote Alarm Terminal

- The terminal of the remote alarm is installed at the lower left side of the appliance. The alarm signal is output from this terminal.
- The carrying capacity of the terminal is AC 220V, 10A.
- Terminal output: the alarm terminals are in open circuit normally, and in closed circuit if there's alarm.

⚠Caution: The alarm will be activated when the power cord falls down or the power supply cut off.

Compressor Delay Setting

In order to drop the power load after power recovery, the delay of the compressor I could be modified.

⚠Caution:

- The delay during I and II compressor can't be modified.



When the power capacity is enough, it is not necessary to modify the delay

Alarm and Security Functions

This appliance has alarm and security functions of the table as below, and also has the function of self-diagnosis

Alarm and Security Functions:

Alarm and Security Functions	Status	Indication	Buzzer	Safety Operation
High-temperature alarm	When the temperature in the cabinet is higher than the set value for a while	Alarm indicator lights on, display window flashes Hi	Ring	Remote alarm activates
Low-temperature alarm	When the temperature in the cabinet is lower than set value for a certain period	Alarm indicator lights on, display window flashes Lo		
Power failure alarm	When the power is disconnected	Alarm indicating lamp flashes	Ring	
Door alarm	When the door keeps open over the setting value	Door alarm indicating lamp lights on	Ring	
Condenser alarm	When the condensing filter is blocked or cooling fan is failure	condenser alarm indicating lamp lights on, display window flashes AC	Ring	
Ambient temperature alarm	When the ambient temperature exceeds 32°C	Ambient temperature alarm indicating lamp lights on	When the ambient temperature exceeds 35°C Ring	
Sensor failure	When the temperature sensor is failure	Sensor failure indicator lights on, display window flashes E0	Ring	
	When the ambient temperature sensor is failure	Sensor fault alarm indicator lights on, display window flashes E1		
	When the condenser sensor is failure	Sensor fault alarm indicator lights on, display window flashes E2		
	When the heat exchanger sensor is failure	Sensor fault alarm indicator lights on, display window flashes E3		

 **Caution:** The freezer recover the operation after power failure with the temperature setting before power failure as the inside temperature setting and alarm temperature setting are memorized in the nonvolatile memory.

Routine Maintenance

Warning

- Warning: Always disconnect the power supply to the appliance prior to any repair or maintenance in order to prevent electric shock or injury.
- Make sure you will not inhale medicine or suspended particles around the appliance at the time of maintenance; these possibly be harmful to your health.

1. Clean the Cabinet

- Please clean the cabinet once a month. Periodical cleaning keeps the appliance looking new.
- Use a dry cloth to wipe off small amounts of dirt on the outside and inside of the appliance and all accessories, If the appliance is dirty, clean it with a diluted neutral dish washing detergent. (Undiluted detergent can damage the plastic components. For the dilution, refer to the instruction of the detergent.)After the cleaning with the diluted detergent, always wipe it off with a wet cloth. Then wipe off the cabinet or accessories with a dry cloth.
- Never pour water onto or into the appliance. Doing so can damage the electric insulation and cause failure.
- The compressor and other mechanical parts are completely sealed and the appliance requires absolutely no lubrication.
- The fan is installed behind the compressor, so please be very careful when insert the hand in this part.

2. Clean the Condenser and Filter

When condenser alarm indicating lamp lights on, please clean the filter or condenser. If the cooling fan is failure, please notify the professional technician to replace the fan. Even the indicating lamp is not on, the filter shall also be cleaned once a month. If the filter is jammed, it may shorten the service life of the compressor and lead to a bad performance.

- Please following the steps to clean the filter and condenser:
 - a. Twist down the four fixed screws from the air inlet grille.
 - b. Take out the filter from air inlet grille.
 - c. Clean the filter and grille with clear water.
 - d. Blow away the dust from the condenser with compressed air.
 - e. Install back the filter and air inlet grille.
 - f. If the condenser alarm indicator lights on before cleaning, check if it is off after cleaning.

Warning

Do not touch the condenser directly when taking out and cleaning the filter. It may cause injury since its surface is hot.

3. Defrosting

The frost is built at the upper portion of the appliance and inner door. The excessive frost possibly make some gap between the cabinet and door gasket, which may cause poor cooling. Remove the frost on the inner door with a scraper enclosed with the appliance. Defrost the cabinet with following steps.

 Caution: For removing the frost, do not use a tool with sharp edge such as a knife or a screwdriver

- Please turn off the backup cooling system if have.
- Take out and transfer all the objects to another cabinets or containers which is



refrigerated by liquid carbon dioxide or dry ice.

- Turn off power switch of the freezer.
- Open the external door and internal door. Hold up the internal door and take it away.
- Keep the external door open to defrost for a moment.
- Clean the water with dry fabric from the bottom of the cabinet.
- After cleaning the cabinet and internal door, put the internal door back; please restart the appliance according to the “Switch on the Appliance”.
- Put the objects into the thoroughly refrigerated cabinet.

Turn on the back-up system if it is provided.

Failure Recovery

Please check the fault as following before notifying the repair service:

Faults	Checking/Solutions
The cabinet is not fully cooled	<ul style="list-style-type: none">· Check the appliance if connect to the power supply?· Check if the power voltage is too low? (Under this condition, please notify the electrician.)· Check if the power switch is turned on?· Check if the fuse blowing?· Check if too much objects are stored in the cabinet?
Poor cooling performance	<ul style="list-style-type: none">· Check if the ambient temperature is too high?· Check if the internal door is completely closed? Check if the external door is closed firmly? (The frost or ice between the cabinet and door gasket possibly prevents door seal)· Check if the air inlet grille is blocked?· Check if the filter is dirty and blocked? When the condenser alarm



	<p>indicator lights on, please clean the filter and condenser.</p> <ul style="list-style-type: none">· Check if the internal door is installed correctly?· Check if the temperature is set correctly?· Check if the grille is jammed?· Check if the cabinet is far from direct sunlight?· Check if the cabinet is near the heat source?· Check if the rubber cover and insulating material of the cable port are installed correctly?· Check if too much objects are stored in the cabinet?
--	---

 **Caution:** If the problem is not solved or the problem is not listed in the above table, please contact with the after-sale technicians.

Disposal of Abandoned Appliance

<ul style="list-style-type: none">➤  Warning➤ If the appliance is to be stored unused in the open area for an extended period, ensure that children don't approach the appliance and the cabinet door can not be closed completely.➤ The abandoned appliance shall be handled by appropriate personnel. Remove the cabinet doors to avoid accidents such as suffocation.
--

Storage Box Rack (Optional)

The optional storage box rack are useful to store the small size materials in the appliance effectively. When the racks are used, it is necessary to adjust the height of the shelves.



Specification

Name	Ultra-low temperature freezer		
Model	YR05108	YR05109	YR05110
External Dimension(mm)	872×1028×1945.5(W*D*H)	872X1192X1994.5(W*D*H)	1229X1012X1994.5(W*D*H)
Internal Dimension(mm)	606×575×1180(W*D*H)	606X738X1310 (W*D*H)	963X571X1350(W*D*H)
Effective Volume	408L	588L	728L
Exterior	Painted Steel Panel		
Interior	Stainless steel		
Outer Door	Painted Steel Panel		
Inner Door	Stainless steel, 2 doors		
Shelf	3 stainless steel shelves (adjustable) Dimension: 580X521(W*D mm) Load: 40kg/shelf	3 stainless steel shelves (adjustable) Dimension: 586X689(W*D mm) Load: 40kg/shelf	3 stainless steel shelves (adjustable) Dimension: 937X 506(W*D mm) Load: 40kg/shelf
cable Port	25mm Diameter, 1 holes (back)		
Insulation	Rigid polyurethane foamed and VIP		
Evaporator	Tube type		
Condenser	Tube plate type		
Refrigerant	R4001 350g	R4001 320g	R4001 370g
Controller	Microcomputer control system		
Temperature display	Digital display		
Temperature Sensor	Platinum resistance (Pt 100)		
Alarm	high-temperature alarm, low-temperature alarm, power failure alarm, door-open alarm, filter cleaning alarm, battery alarm, ambient temperature alarm, condenser alarm, fan alarm		
Remote Alarm Terminal	Max capacity: AC220V, 10A		
Battery	Lead-acid cell, DC12V, 7000mAh, automatic charging		
Accessories	Defrosting scoop		
Net Weight	268kg	303kg	374kg
Optional Parts	Storage Box Rack, Inner door, Temperature recorder(Data logger)		

 Caution:



- Design specifications are subject to change without prior notice.
- The battery for power failure alarm is consumable; it is suggested to replace it every 3 years for once. To replace the battery, please contact the representative of us, agent or after-sale service.

Performance

Model	YR05108	YR05109	YR05110
Cooling Performance	cabinet center-86°C(Ambient temperature 32°C, no-load)		
Temperature Control Range	-40°C~-86°C(Ambient temperature 32°C, no-load)		
Rated Voltage	AC220V,50Hz		
Rated power	890W	1500w	1400w
Noise level	55dB[A](background noise, 20dB)		

⚠Caution:

✘**Performance:** when the ambient temperature is 32°C, the temperature in the cabinet reaches -86°C (Unload).

Packing List

Model	User Manual	Limiting location Clip	Shelf	Buckle	Cream shovel	Handle	Screw
Quantity	1	2	3	12	1	1	4



All rights reserved © KALSTEIN France S. A. S.,
Optimum Business Center 450 Rue Baden Powell,
• 34000 Montpellier, France.
Tlf: +33 467158849 / +33 680760710/ +33 663810023
<https://kalstein.eu>
KALSTEIN FRANCE, S. A. S

