

Tissue Embedding & Cooling System
YR443

Instruction Manual

Thank you very much for purchasing our Tissue Embedding & Cooling System YR443.

Please read the "Operating Instructions" and "Warranty" before operating this unit to assure proper operation. After reading these documents, be sure to store them securely together with the "Warranty" at a hand place for future reference.



Warning: Before operating the unit, be sure to read carefully and fully understand important warnings in the operating instructions.

Content

I . Introduction.....	2
II . Functions and features	2
III . Main technical parameters.....	3
IV . Sketch of the Instrument	4
V . Sketch of the Operating Panel and Its Functions.....	4
VI . Ways for Operations.....	5
VII . Attentions.....	7
VIII . Maintenance Service.....	8
IX . Translocation and storage	8

I. Introduction

YR443 Model Tissue Embedding & Cooling System is the regular instruments used to embed pathological tissues. It is used to cool and embed the tissues of human body or the zoological and botanical tissues after dehydration and paraffin soaked. The advanced controlling-microprocessor and the new PTC calorific material have been applied to this machine. It is also equipped with five temperature control lines and multiple overheat-avoidance devices. And with the device of time initialization (automatically startup) for a seven-day week, the client can choose to set the start time (X Day, X hour X Minute) in advance to melt down the paraffin. It is novelty in form, precise in structure, stable in performance and easy for operation. And the Cooling platform is composed of disassembled parts for free combination.

This machine is advanced both abroad and at home. It is the practical and necessary instrument for pathological study and teaching for hospitals, medical schools, scientific research institutes and food quarantine and inspection organizations.

II. Functions and features

1. The new PTC calorific material has been used to make it heat up quickly and heated equally, and energy-saving.
2. The fully automatic procedure control can make it possible for presetting the start time of any weekday. If it is set as 00 o'clock 00 minute of a weekday, that means to cancel the fixed time of this day.
3. The odd controlling-microprocessor from American ATMEL Corporation has been used to make it easy to set up temperature and the shining tube has been used to display the temperature so that we can clearly know that it is in the working state.
4. The temperature survey integration block from American DALLAS Corporation has been used to make it precise in temperature survey and credible in performance.
5. It possesses the function of memorization to keep the set temperature automatically after startup.
6. It is safe by employing the dual overheat-avoidance devices to protect the heating system.
7. Big stainless steel paraffin tank of 5 liters capacity.
8. The separate cooled spot for a quick cooling of specimens.
9. Free choice for manual control or foot control.
10. The lowest temperature of the Cooling platform can be 20°C below zero (-20°C), and the

delay protection has been provided with.

11. The illuminating lamp has been provided for the operation to the minimum specimen tissues.

12. Precise in time display, and it is simple for timing.

III. Main technical parameters

1. Range for setting the temperature of the heater: 55~70°C.
2. Range for temperature control of the heater: ±3%.
3. Range for automatic running time-setting: any weekday, any hour, any minute
4. The lowest working temperature of the Cooling platform: ≤-20°C.
5. The temperature of Cooled spot: 5°C.
5. Size of the working quarter:
 - Volume of the paraffin: 228×148×90mm
 - Volume of the preservation box: 228×148×50 mm×2
 - Size of the embedding table: 170×90 mm
 - Size of the Cooling platform: 320×300 mm
6. Voltage: AC 110V±10%V 60Hz±1Hz, Power: ≤1500VA
7. External dimensions & Weight:
 - Cooling platform: 345×500×360 mm, 25 kg.
 - Embedding machine: 550×500×360 mm, 29 kg.

The picture of Embedding & Cooling System is as below:



IV. Sketch of the Machine

YR443 Model Tissue Embedding & Cooling System is composed of five heating quarter and one Cooling quarter. (See Picture 1)

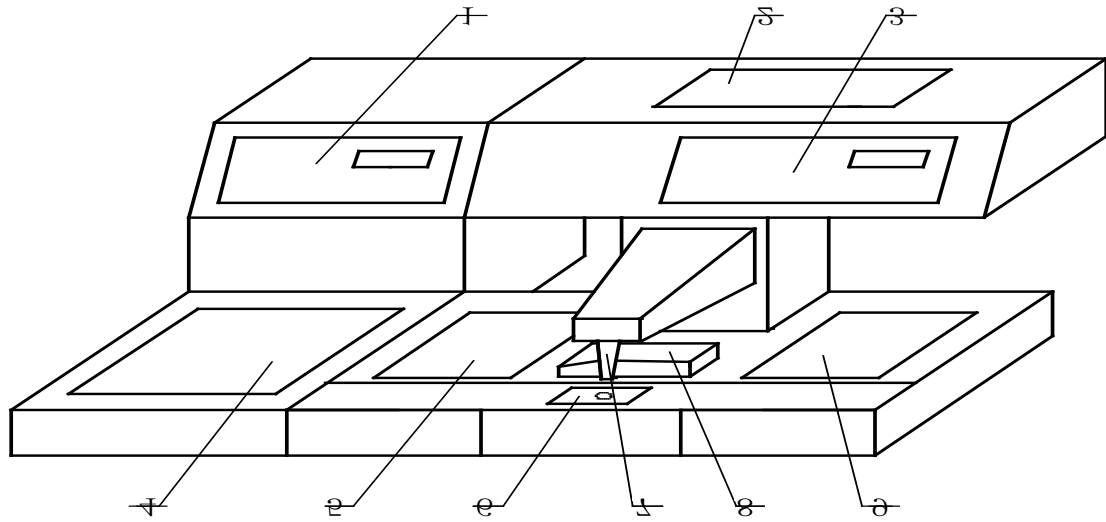

- | | |
|--|-----------------------|
| 1、 Display Screen of Cooling platform | 2、 Paraffin container |
| 3、 Display Screen of embedding machine | 4、 Cooling platform |
| 5、 Left preservation box | 6、 Operating table |
| 7、 Paraffin nozzle | 8、 Forceps store |
| 9、 Right preservation box | |

(Picture 1) Sketch of the Machine

V. Sketch of the Operating Panel and Its Functions

1. Sketch of the Operating Panel

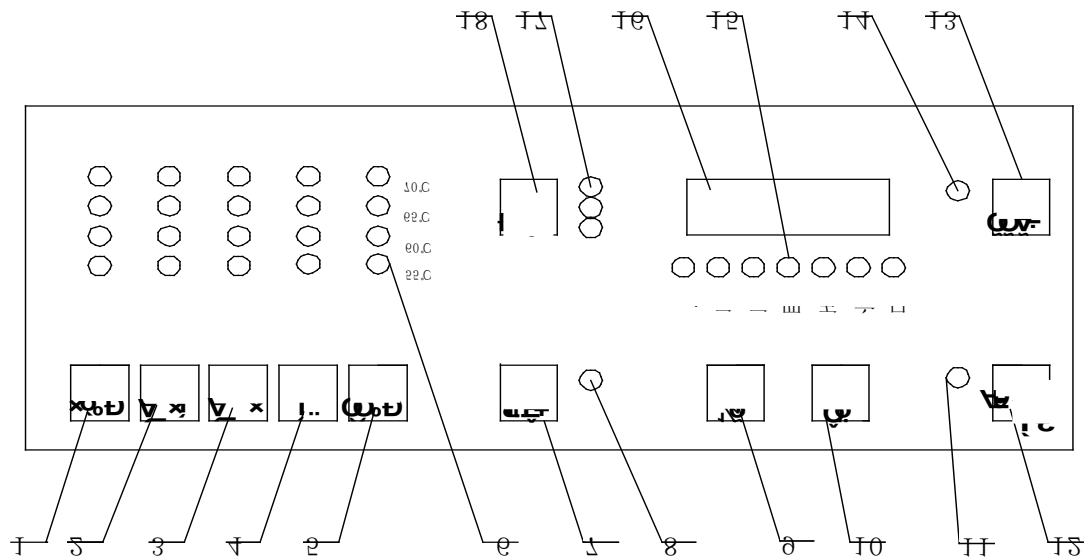

- | | |
|--|----------------------------------|
| 1、 Temperature setting for Left preservation box | 10、 Up |
| 2、 Temperature setting for Paraffin nozzle | 11、 Startup/Stop Indicator |
| 3、 Temperature setting for Paraffin container | 12、 Startup/Stop |
| 4、 Temperature setting for Operating table | 13、 Switch for illuminating lamp |

- | | |
|---|--------------------------------------|
| 5、 Temperature setting for Right preservation box | 14、 Indicator of illumination switch |
| 6、 Temperature Indicator and working Indicator | 15、 Indicator for weekday |
| 7、 Time setting | 16、 Time display screen |
| 8、 Fixed time Indicator | 17、 Indicator of week, hour, minute |
| 9、 Down | 18、 Timing |

2. Sketch of the Rear Operating Panel

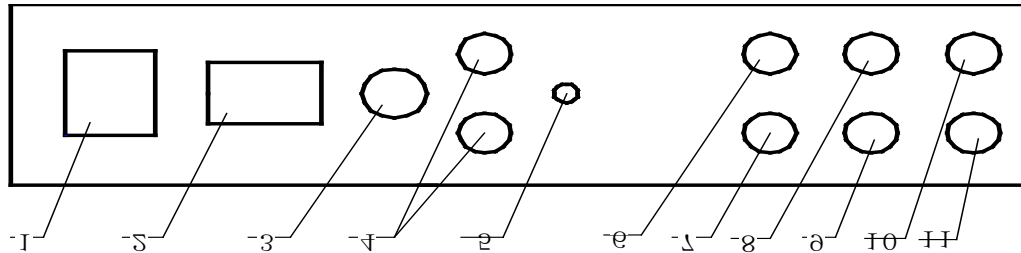

- | | |
|---|---|
| 1、 Power switch | 7、 F ₂ Fuse of paraffin nozzle (6A) |
| 2、 Power socket | 8、 F ₃ Paraffin container (6A) |
| 3、 Foot switch socket | 9、 F ₄ Fuse of operating table(3A) |
| 4、 Fuse of the machine(10A) | 10、 F ₅ Fuse of right box (3A) |
| 5、 Grounding column | 11、 F ₆ Fuse of illuminating lamp (3A) |
| 6. F ₁ Fuse of left box (3A) | |

VI. Ways of Operation

- 1、 Get ready. Firstly, put enough paraffin blocks into the paraffin container.
- 2、 Start the machine. Get through the power supply by connecting the power line of AC110V with the power socket on the rear panel, and press down the switch, the power has got through when the green light of the switch indicator is bright.

Attention: For the easy operation to users, we have preset the regular temperatures of the five heating zones in advance: Left box 55°C, paraffin nozzle 70°C, paraffin container 65 °C, working table 55 °C, right box 55 °C. If the user thinks it is appropriate, just directly presses the “Start/Stop” key to put it into work.

3、 Temperature Setting

Before using the machine, the temperatures of the five heating zones should be set. Do as follows: Temperature setting should be done when the "Start/Stop" indicator shuts off. For instance, Press the “preservation box” key, the temperature will increase 5°C for each time, and the corresponding number (cycling from 55°C~70°C) indicator becomes bright. Do the same to other working zones.

When the user wants to stop heating in a working zone, all the indicators in this zone can be set shutoff. For instance, if the user wants the working table to stop heating, press the “working table” key to shut off all the corresponding indicators. Press the “Start/Stop” key, the “Start/Stop” indicator becomes bright, and the working zone begin to heat up, the temperature display tube will change from “Green” into “Red”, When reaching the set temperature, the indicator will change from “Red” into “Orange”.

“Red” indicates that the heater is heating up.

“Green” indicates that the heater is at the state of temperature setting.

“Orange” indicates that the temperature has reached the set one and the heater is at the state of heat holding.

The preset temperature will automatically be memorized by the computer chip. If the user does not want to change the preset temperature, press the “Start/Stop” key to start heating.

4、 Timing

Press the “Timing” key for three seconds, the indicator for Weekday becomes bright, then press “Up” or “Down” key to choose the weekday (from 1 to 7), when finishing the setting, the corresponding weekday indicator will become bright.

Press the “Timing” key to set Hour, the indicator for hour becomes bright and “00” will be displayed, then press “Up” or “Down” key to choose the hour (from 0 to 23) to finish the hour setting.

Press the “Timing” key to set Minute, the indicator for minute becomes bright and “00” will be displayed, then press “Up” or “Down” key to choose the Minute (from 0 to 59) to finish the Minute setting.

At last, press the “Timing” key to finish the Time setting, and all the indicators will shut off.

5、 Time Setting

Press the “Time Setting” key for three seconds, the “Fixed Time” indicator becomes bright for fixed-time startup setting. When the weekday indicator becomes bright, press “Up” or “Down” key to choose the weekday (from 1 to 7), when finishing the setting, the corresponding weekday indicator will become bright., then press the “Time Setting” key to finish the weekday setting.

Press the “Timing” key to set Hour, the indicator for hour becomes bright and “00” will be

displayed, then press “Up” or “Down” key to choose the hour (from 0 to 23), then press the “Time Setting” key to finish the hour setting.

Press the “Timing” key to set Minute, the indicator for minute becomes bright and “00” will be displayed, then press “Up” or “Down” key to choose the Minute (from 0 to 59), then press the “Time Setting” key to finish the Minute setting.

When finished setting the fixed-start-time, all the indicators will shut off.

Attention:

When 00 Hour 00 Minute has been set, the machine will stop startup that day.

VI. Attention

1. After getting the machine, please open the package to examine the outer appearance, check the appurtenances, and read the instruction carefully before starting and operating the machine.

2. In order to ensure the security of people and the equipment, the three-line power source is needed, and make sure that the grounding works well. Non-grounding power is prohibited to this machine.

3. Before the paraffin completely liquated, or before the paraffin nozzle has reached the set temperature, do not use the manual or foot switch in order to prevent the nozzle from leaking paraffin and the pipeline blockage.

4. The overheat protector has been equipped to this machine. When the temperature of the heater surpasses the dangerous temperature 100 °C, the overheat protector can automatically turn off the power source of heating. When the temperature becomes lower, the machine will automatically return to its heating state.

5. In order to lengthen the service life of the Cooling compressor, the successive working time should be within 4 hours. And a more-than-five-minute gap is needed for restarting the machine after the power absence.

VIII、 Maintenance Service

Under the condition of following the instructed operating regulations, we guarantee to keep our promise of free maintenance service within one year from the sales day. To those which have

surpassed the period, we will also provide maintenance service according to the stipulations.

IX、 Translocation and Storage

Translocation: Handle in care, avoid wetting, and place upward.

Storage: This machine should be stored in the clean and airy indoor places with the relative humidity under 80% and be kept far from the caustic gas.

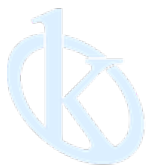

All rights reserved © KALSTEIN France S. A. S.,
Optimum Business Center 450 Rue Baden Powell,
• 34000 Montpellier, France.
Tlf: +33 467158849 / +33 680760710/ +33 663810023
<https://kalstein.eu>
KALSTEIN FRANCE, S. A. S

