

Thermostatic Bath
Model Series YR04985
Instruction Manual

Thank you very much for purchasing our Thermostatic Bath

Model Series YR04985.

Please read the “Operating Instructions” and “Warranty” before operating this unit to assure proper operation. After reading these documents, be sure to store them securely together with the “Warranty” at a hand place for future reference.



Warning: Before operating the unit, be sure to read carefully and fully understand important warnings in the operating instructions.



I. Product Overview

II. Product Features

III. Instrument Structure

IV. Parameters Specification

V. Instrument Installation and Commissioning

VI. Temperature Controller Button Operation and Description

VII. Instrument Precautions for Use and Maintenance

VIII. Instrument Fault Analysis and Elimination



I. Product Overview

The YR series cryogenic thermostatic bath is the common necessary regularity equipment in lab. It is widely used in bioengineering, national defense, medicine, food, chemical industry, metallurgy, chemical analysis, petroleum and other fields, providing users with a constant field source of high precision, control and uniform temperature, which is the ideal thermostatic bath for major small and medium-sized research institutes, universities, factory laboratories, and quality inspection departments.

II. Product Features

The YR series cryogenic thermostatic bath is a type of intelligent microcomputer temperature control thermostatic bath, which is of following features:

1. Adopting new high microcomputer temperature control PID adjustment technology with high temperature control accuracy.
2. The intelligent all-digital system could correct the deviation of the temperature measurement value, with the digital display resolution at 0.1 °C.
3. Adopting imported temperature sensor.
4. The refrigeration system is of multiple protection functions of overheating and overcurrent.
5. Intelligent instrument control, simple operation, decent temperature stability, with upper and lower limit over temperature alarm function.
6. It is equipped with fully efficient anti-interference compressor.
7. The cooling speed is speedier than similar products, with less noise and vibration.
8. Double window red and green colors are applied, with red upper window measurement value (PV) and green the lower window setting value (SP) in LED display.
9. There are internal and external circulations. During the external circulation, the thermostatic liquid in the tank (box) could be led out to create a second constant temperature field. It could also be taken as the cold source (heat source) to direct the liquid to get out of the tank (box), which could reduce (elevate) the temperature of the experimental container outside the tank and expand the utilization range. Likewise, it is of fine appearance.

III. Instrument Structure

This product is the YR series cryogenic thermostatic bath. The liner is welded with stainless steel as a whole, with the shell of high-quality cold-rolled sheet. Temporarily, it was processed with plastic spraying to enhance the anti-corrosion effect, together with the intelligent temperature control and Pt100 platinum resistance temperature sensor. The heating system consists of a high-efficiency U-shaped electric heating tube. The refrigeration system is composed of a fully efficient anti-interference compressor, evaporator, etc. The thermostatic control adopts the international



advanced anti-integral saturation PID control system to prevent the phenomenon of temperature shock during the heating process, thereby upgrading the control accuracy.

IV. Parameters Specification

Specification:

Model	Temperature	Stability	Flow	Lift	Capacity	Opening	Depth	Product size
	(°C)	(°C)	(L/min)	(m)	(L)	(mm)	(mm)	W*D*H(mm)
YR04985	-5~100	±0.05	14L/min	12	10	160*140	180	450*360*820
YR04986	-10~100	±0.05	14L/min	12				
YR04987	-20~100	±0.05	14L/min	12				
YR04988	-30~100	±0.05	14L/min	12				600*540*950
YR04989	-40~100	±0.05	14L/min	12				
YR04990	-5~100	±0.05	14L/min	12	20	210*210	180	500*400*820
YR04991	-10~100	±0.05	14L/min	12				
YR04992	-20~100	±0.05	14L/min	12				
YR04993	-30~100	±0.05	14L/min	12				600*570*950
YR04994	-40~100	±0.05	14L/min	12				
YR04995	-5~100	±0.05	14L/min	12	30	310*280	180	600*480*820



YR04996	-10~100	±0.05	14L/min	12				
YR04997	-20~100	±0.05	14L/min	12				
YR04998	-30~100	±0.05	14L/min	12				700*650*95
YR04999	-40~100	±0.05	14L/min	12				0

V. Instrument Installation and Commissioning

1. Unpack and satiate the product, then put it on a fixed firm workbench.
2. Add liquid medium into the tank and leave its' level lower than the workbench by about 30mm.
3. Connect the circulation pump inlet and outlet pipes.
 - a) When the circulation pump does not require external circulation, just connect the "inlet pipe" and "outlet pipe" with a hose.
 - b) When the circulating pump is used for the external circulation of constant temperature liquid, two hoses should be used to connect the "outlet" tube to the inlet of the experimental container outside the tank, and the "inlet" tube to the outlet tube of the experimental container outside the tank.
4. Turn on the power, as well as the "power" switch and the "circulation" switch.

At this time, PV and SP are in the initialization state, as shown below:

(For specific operation of the instrument, please refer to Section VI- Temperature Controller Button Operation and Description)

When the set temperature is lower than normal temperature, turn on the cooling switch.



VI. Temperature Controller Button Operation and Description

1. Overview

DHH-C2006 controller is of fine appearance, comprehensive functions and trouble-free operation. It is suitable for low-temperature and high-low temperature thermostatic equipment controlled by single compressor.

2. Main parameters specifications and requirements

a. Power supply voltage: 220V AC \pm 10%; Ambient temperature: 0 \sim 50 $^{\circ}$ C; Relative humidity: <85% RH;

b. Temperature sensor: PT100;

c. Temperature setting range: -90.0 \sim 300.0 $^{\circ}$ C; Temperature measuring range: -99.0 \sim 315.0 $^{\circ}$ C;

d. Basic error of temperature measurement value: <0.1%;



e. Output contact capacity: Heating power \leq 1.6 KW (resistive load)

Refrigeration relay \leq 4 A (inductive load); Circulation relay \leq 1 A (inductive load);

Stirring relay \leq 1 A (inductive load); Switching relay \leq 1 A (inductive load);

3. Panel Instructions:

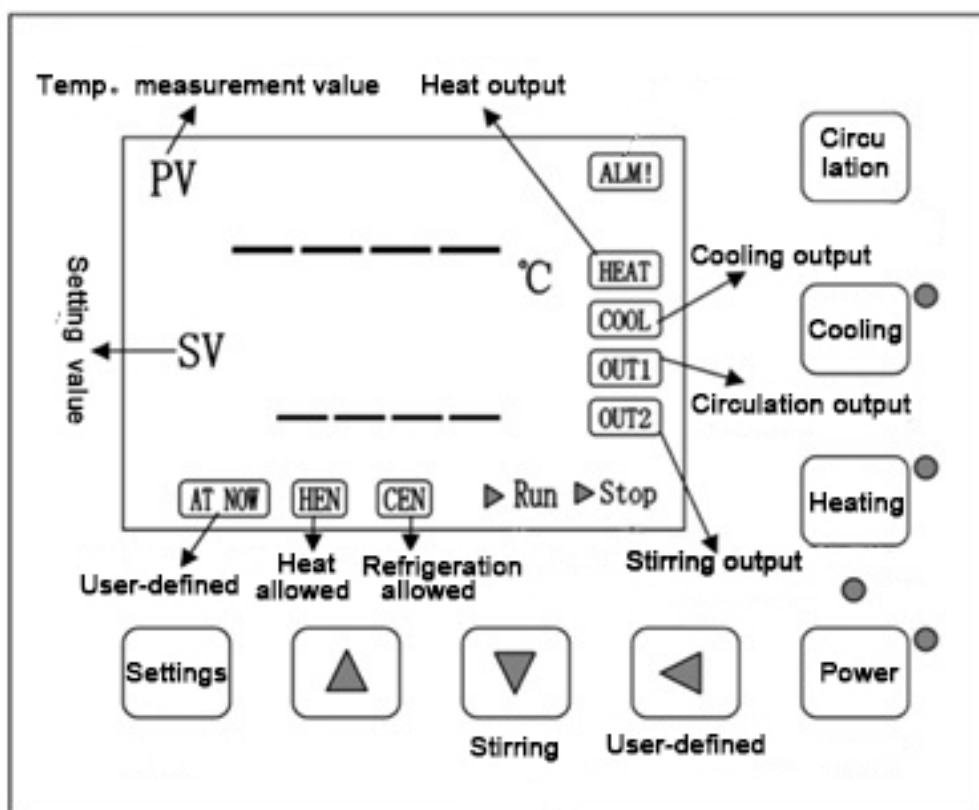



4. Buttons Definition:

a. "Power": Press this button continuously for PoT seconds (see "V. Internal Parameter Table-3") to turn on or off the display and all outputs of the controller itself.

Note: When the controller is turned off by this button, the power supply of the device would not be really cut off. Therefore, if the device would be idle for a long time, it is strongly recommended to unplug the external power supply of the device!

b. "Circulation": Circulation output button.

c. "Cooling" and "Heating": Allows the button to be switched on for cooling and heating.

d. "Setting": In the normal display state, click this button to enter the temperature setting state, long press this button to enter the internal parameter setting state.

e. ◀ (shift) button: Click this button in the setting state to make the setting value shift and flash to modify. In the normal display state, long press this button for 5 seconds to enter the temperature auto-tuning selection state.

f. "▼" (decrease) button: Click this button in the setting state to decrease the setting value, and long press this button to decrease the setting value continuously. In the normal display state, click this button to switch the stirring output.

g. "▲" (increase) button: Click this button in the setting state to increase the setting value, long press this button to continuously increase the setting value.

5. Operation and Usage

a. When the instrument is powered on, the controller is in the display and all output is off. Click the "power" button to enter the normal working state.

b. Temperature Setting

In the normal display state, click the "Setting" button to enter the temperature setting state. The upper window displays the prompt "SP" and the lower row displays the temperature setting value. After modifying to the desired setting value, then click the "Setting" button to exit this setting state, and the modified setting value would be saved automatically.

c. Internal Parameter Setting

In the normal display state, long press the "Setting" button for 3 seconds, the upper window of the display window displays the password prompt "PA", the lower row displays the password value, after modifying the desired password value. Then click the "Setting" button if the password value is incorrect, the controller would automatically return to the normal display state. If the password value is correct, enter the internal parameter setting state, and then click the "Setting" button to modify each parameter in turn (see the internal parameter table for details); Press and hold the "setting" button for 3 seconds to exit this state, and the parameter value is automatically saved.



Note: The temperature setting value: hereinafter referred to as SP; the first temperature measurement value: hereinafter referred to as PV;

Internal Parameter Table-1

Parameter indication	Items	Parameter function description	(Range) Defaults
PA	Password	When PA = 3, you could view and modify the parameter value.	0
HAL	Upper deviation Over temperature alarm	When "PV > SP + Hal", there is upper deviation over temperature alarm.	(0~50.0°C) 30.0
CuP	Compressor Start threshold 1	When refrigeration is allowed, If "PV > SP + Cup", start the compressor output.	(0~50.0°C) 5.0
Cdn	Compressor Close threshold 1	If "PV < SP + CDN", turn off the compressor output.	(-50.0~0°C) -5.0
Enb	Parameter enable	0: invalid lcup and LCDn parameters; 1: lcup and LCDn parameters are valid.	(0~1) 0
LCuP	Compressor Start threshold 2	Note 1	(0~50.0°C) 0.0
LCdn	Compressor Close threshold 2	Note 1	(-50.0~0°C) -10.0
Pb	Temperature correction	Correct the error in temperature measurement. $Pb = Pb + (\text{actual temperature value} - PV)$ Note 2	(-50.0~50.0°C) 0
PL	Low temperature Slope correction	Slope correction of temperature measurement value when "PV < 0 °C" $PL = 1000 * (\text{actual temperature value} - PV) / PV$ Note 2	(-999~999) 0
PH	High temperature Slope correction 1	Slope correction of temperature measurement value when "PV > 0 °C" $PH = 1000 * (\text{actual temperature value} - PV) / PV$ Note 2	(-999~999) 0
Addr	Postal address	Product mailing address.	(1~32) 1
SPLc	Setting lock	0: temperature setting value could be modified; 1: do not modify the temperature setting.	(0~1) 0

Note 1: When both "Enb = 1" and "SP < dP (see internal parameter table-3 for details)" and "Refrigeration permission on" and "Heating permission on" are both satisfied:

If "PV > SP + LCuP", start the compressor output, if "PV < SP + LCdn", turn off the compressor output;

When other refrigeration permits:

If "PV > SP + CuP", start the compressor output, if "PV < SP + Cdn", turn off the compressor output.

Note 2: Use Pb to correct the error at normal temperature (preferably 0 °C), while PL for lower temperature (such as -40 °C) and PH for higher temperature (such as 200 °C).

Internal Parameter Table-2 (Note: see Internal Parameter Table-3 for parameter "DP")



Parameter Indication	Items	Parameter Function Description	(Range) Defaults
PA	Password	When PA = 9, you could view and modify the parameter value.	0
T	Control period	Heating control circulation.	(1~60 s) 3
P1	Scale band 1	When "SP ≥ DP", the time proportion is adjusted.	(1~300.0) 40.0
I1	Integration time 1	The regulation of integral action when SP ≥ DP.	(1~2000 s) 200
D1	Differential time 1	Regulation of differential action when "SP ≥ DP".	(0~1000 s) 150
P2	Scale band 2	When "SP < DP", the time proportion is adjusted.	(1~300.0) 30.0
I2	Integral time 2	Regulation of integral action when "SP < DP".	(1~2000 s) 200
D2	Differential time 2	Regulation of differential action when "SP < DP".	(0~1000 s) 200

Internal Parameter Table-3

Parameter Indication	Items	Parameter Function Description	(Range) Defaults
PA	Password	The parameter value could be viewed and modified when PA = 27.	0
Pon	Power off recovery Function selection	0: no power off recovery function; 1: it has power-off recovery function.	(0~1) 0
NodE	Working mode	Note 3	(1~3) 1
FcH	Relay Function selection	0: when "PV > DP", the normally open point of relay is closed; otherwise, its normally open point is open. 1: when "PV > DP" and the compressor are started, the normally open point of the relay is closed; otherwise, the normally open point is open. 2: when there is temperature deviation over temperature alarm, the normally open point of relay is closed; otherwise, the normally open point is open. 3: when the refrigeration is allowed (CEN character is on), the normally open point of the relay is closed; otherwise, the normally open point is open.	(0~3) 0
DP	Dividing point	Dividing points of solenoid valve, refrigeration, PID and self-tuning functions. Note: see specific functions for details.	(0~300.0°C) 50.0
CT	Compressor Start delay	The minimum interval between shutdown and restart of refrigeration compressor.	(0~600 s) 180



CnP	No compressor working point	When $PV \geq CNP$, the compressor is not allowed to work; otherwise, the compressor is allowed to work.	(0~300.0°C) 300.0
NP	Maximum Power output	The maximum power percentage of the heating output.	(0~100%) 100
Co	Turn off heating output deviation	When " $PV \geq (SP + CO)$ ", absolutely turn off the heating output.	(0~20.0°C) 20.0
DF	Display Insensitive area	The insensitivity area of the temperature display of the measured value.	(0.0~0.9°C) 0.1
PoT	Power key Effective time	The power key is only valid if the pot time is pressed continuously.	(0~3s) 0
S1T	Sina switch judgment delay	When the sin1 switch is short circuited continuously for s1t, the controller has its fault prompt and handling.	(0~180 s) 0
S2T	Sin2 switch judgment delay	When the sin2 switch is short circuited continuously for s2t, the controller has its fault prompt and handling.	(0~180 s) 0
SPL	Minimum temperature Setting value	Minimum value of the temperature setting.	(-90.0~0°C) -90.0
SPH	Maximum temperature Setting value	The maximum value of the temperature setting.	(0~300.0°C) 300.0

Note 3:

- 1) Mode 1: Manual mode, the power button directly into the running state after turning on, regardless of "circulation", the "heating" and "cooling" keys are valid, and the corresponding heating and cooling permission indicators are on or off.
- 2) Mode 2: Manual mode, after the power button is turned on, it stops. Click the "circulation" button to start and stop operation, the LCD screen displays the corresponding prompt "Run" or "Stop", in the running state, "heating" and cooling" is only valid, and the corresponding heating and cooling permission indicators are on or off. In the stop state, the "heating" and "cooling" keys are invalid.
- 3) Mode 3: Automatic mode, the power button directly enters the running state after being turned on, the controller automatically controls the heating and cooling output, the "heating" and "cooling" keys are invalid, and the heating and cooling allow indicator lights automatically turn on or off.

Internal Parameter Table-4

Parameter indication	Items	Parameter function description	(Range) Defaults
PA	Password	When $PA = 81$, you could view and modify the parameter value.	0
ACT	Allowed cumulative usage time	When " $trun \geq act$ ", there is an error code display, and the device is forbidden to run again. Note: If " $Act = 0$ ", continuous operation of the equipment is allowed.	(0-9999 hours) 0
Trun	Running time	Equipment operation time, not modifiable.	(0-9999 hours) 0



d. Abnormal temperature alarm

If "----" is displayed in the upper row of the display window, it indicates that the temperature sensor is faulty or the temperature exceeds the measurement range or the meter itself is faulty. The meter automatically turns off the heating output. The buzzer continuously sounds and the "ALM!" character lights up, please check on the sensor and its wiring.

e. Solenoid Valve Function (see Internal Parameter Table-3 for details)

f. Mixing Function

In the normal display state, click the "Decrease" button to switch the stirring output.

Note: In the running or stop state, the stirring function is effective, but if there is an error code or abnormal temperature alarm display, the stirring function is invalid.

g. When the over-temperature alarm occurs, the buzzer sounds intermittently, the "ALM!" Character is always on, and the over-temperature alarm relay output is disconnected.

Note: If an over-temperature alarm occurs due to a change in the temperature setting value, the "ALM!" Character is always on, but the buzzer does not sound.

h. Error Alarm

When the signals "SIN1" and "SIN2" are short-circuited, the error codes "E-01" and "E-02" are displayed respectively.

When the cumulative use time is allowed, the error code "E-05" is displayed.

If an error code is displayed, the controller automatically stops running, disconnects all outputs, and the buzzer continuously sounds. The error code display could not be cleared. If the fault is removed, click the "Power" button to restart the operation.

i. When the buzzer sounds, you could press any key to mute the sound.

6. System Self-tuning

When the temperature control effect is not ideal, the system self-tuning could be performed. There would be a large overshoot in the temperature during auto-tuning. Please fully consider this factor before the system auto-tuning.

In the running and normal display state, long press the "Shift" button for 5 seconds, the upper row displays the auto-tuning prompt "AT". The lower row displays "off", you could click the "increase" or "decrease" button to select the display "on" or "off". When "on" is displayed, click the "setting" button, the auto tuning prompt "AT NOW" flashes, after auto tuning is complete, the "AT NOW" character stops flashing, the controller would group better system PID parameters, parameter values are automatically saved.



During the auto-tuning process, repeat the above operations. When "off" is displayed, click the "Setting" button to terminate the auto-tuning program. If the working mode is 2 or 3, click the "Circulation" button to terminate the auto-tuning program.

When "SP≥dP", the auto-tuning result is saved as P1, I1, and d1. Otherwise, it is saved as P2, I2, and d2.

During the system auto-tuning process, the "heating" key is invalid, the heating output is always allowed, and the heating permission indicator is always on; if there is an over temperature alarm, the "ALM!" Character does not light, and the buzzer does not sound, but the temperature alarm relay output would be disconnected; the temperature and internal parameter settings are invalid.

Special Note: When performing auto-tuning, in order to make the result more accurate, if "SP≥dP" with the compressor is not normally open, please manually turn off the refrigeration output!

7. Wiring Diagram

Special Reminder: In order to reduce the interference to the instrument when wiring, please pay attention to the separation of strong current lines (such as power lines and load lines, etc.) and weak current lines (such as sensor signal lines and button lead lines, etc.).

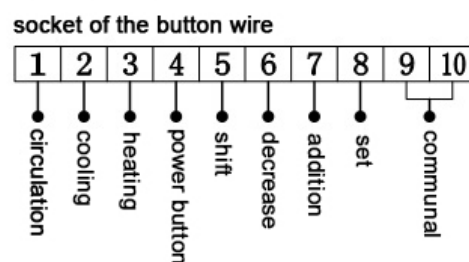
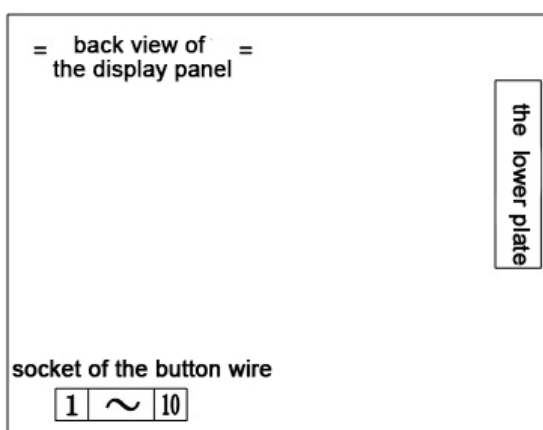

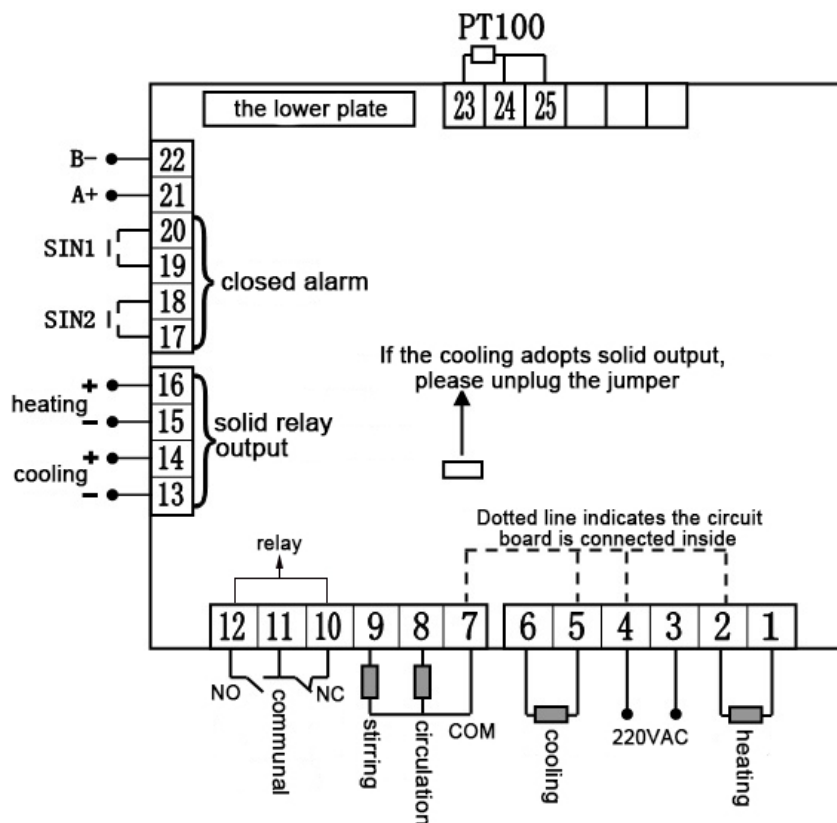

VII. Instrument Precautions for Use and Maintenance

1. The liquid medium must be added into the tank before use, otherwise the heater will be damaged when the power is turned on. The medium liquid level should be about 30 mm lower than the workbench.
2. The selection of liquid medium in the tank should meet the following principles:
 - a. When the working temperature is 5 ~ 85 °C, the liquid medium generally uses water;
 - b. When the working temperature is 85 ~ 95 °C, the liquid medium can choose 15% glycerin aqueous solution;
 - c. When the working temperature is lower than 5 °C, the liquid medium generally uses alcohol or freezing liquid.
3. In order to improve the service life of the refrigeration system, the refrigeration system of this product protects the startup of the refrigeration compressor. After the refrigeration switch is turned off, the refrigeration switch should be turned on again at intervals of 10 ~ 20 minutes (depending on the ambient temperature).
4. Power supply: 220 V / 50 Hz, the power supply should be greater than the total power of the instrument; the power supply is must of a high-quality "ground" device.
5. The instrument should be placed in a dry and ventilated place with no obstacles within 300 mm around the instrument.



6. When the working temperature of the thermostatic bath is low, care should be taken not to enter the bath with hands to prevent frostbite.
7. After use, all switches are turned off to cut off the power.
8. The instrument should do regular cleaning to keep the workbench and operation panel clean.

VIII. Instrument Fault Analysis and Elimination

No	Fault	Reason	Exclude
1	No display	The power supply is not connected normally Fuse damage	Check the cause of power failure and reconnect it Replace the fuse and contact the manufacturer if it is burnt out again
2	No heating	The set temperature is lower than the measured temperature Heater damaged Poor contact of temperature sensor	Reset temperature Contact the manufacturer for repair Check the sensor wiring and connect it or report for repair
3	Show "OUEY" or "0000"	Poor contact or damage of temperature sensor	Check the sensor wiring and connect it or report for repair
4	Uncooled system	The fuse of refrigeration system is damaged Temperature control system is faulty Heating when not heating Air cooled motor does not operate Compressor does not work	Replace the fuse and contact the manufacturer if it is burnt out again Contact the manufacturer for repair Contact the manufacturer for repair Contact the manufacturer for repair



Product Packing List

No.	Item	Quantity	Remarks
1	Mainframe	1	
2	Power cord	1	
3	Upper cover	1	
4	Hose	1	
5	Instruction manual	1	
6	Certificate	1	
7	Warranty card	1	
8	Instrument instruction	1	

