



Drying Oven

Model Series YR0T0

Instruction Manual

Thank you very much for purchasing our Kalstein's Drying Oven Model YR0T0.

Please read the "Operating Instructions" and "Warranty" before operating this unit to assure proper operation. After reading these documents, be sure to store them securely together with the "Warranty" at a hand place for future reference.



Warning: Before operating the unit, be sure to read carefully and fully understand important warnings in the operating instructions.



OUR SERVICES

Benefits and Support

In Kalstein France, we take care of the full satisfaction of our customers, that is why we provide value-added services of the highest level based on our experience.



Online Inductions and Trainings

In any part of the world, receive your induction or training from our specialized team of engineers



Quick Response

Our work team is always available to response all your consults or questions, in order to support you in any situation.



#Letsgivemore

Thanks to your purchase, a donation will be made to a non-profit foundation that fights against breast cancer and helps most vulnerable communities.



Technical Support

Enjoy of personalized advice for the correct preventive and corrective maintenance of your equipment, thanks to Kalstein's manuals and articles, special catalogues and video tutorials.



Delivery Logistics

We take care of all the necessary logistics for the dispatch of your goods, whether is by sea, land or air.



Kalstein Worldwide

With more than 25 years growing with our customers, Kalstein's multiformat and modern content, is now present in more than 10 countries and increasing.



1. Application range

This drying oven is used in medical treatment unit, industry and mining enterprise, universities and colleges and scientific research for drying, melting wax, sterilizing and disinfecting. don't use it to dry any volatile, inflammable and explosive items.

2. Product structure

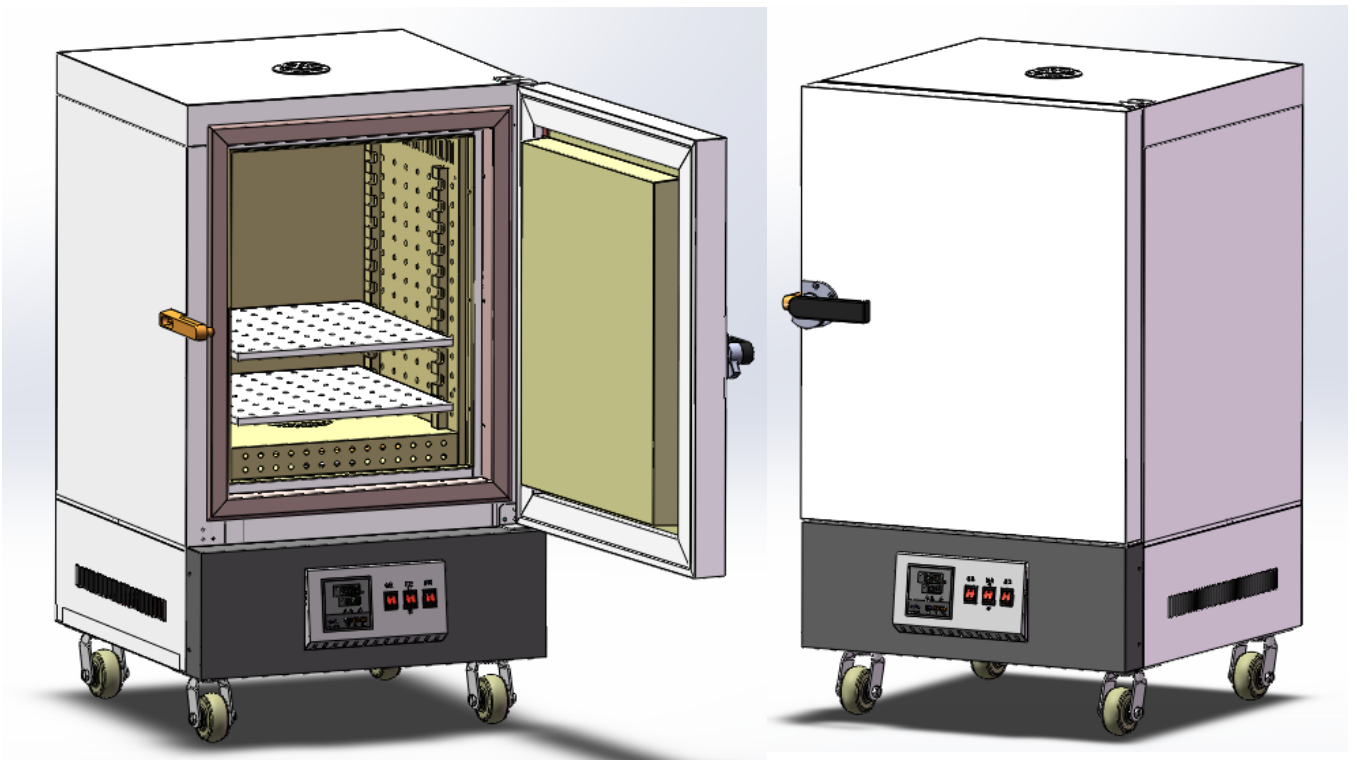

Heating tube is in the bottom of inner chamber, fan in the left of chamber ,temp. controller controls the constant and change of temperature ,the air flow inflows inner chamber via heating tube to fan which make it flows uniformly. arc-design ,shelf space can be adjusted ,built-in temp. probe. inner chamber is



made of high-temperature resistance stainless steel plate

3. Product model and parameter

Model	Interior size (mm)			Exterior size (mm)			voltage AC(V)	Power (KW)	Temp.range (°C)	Fluctuation (°C)
	H	W	D	H	W	D				
YR0T0	450	350	350	1050	580	650	220	4.5	RT+5-600	±5%
YR0T1AS	550	450	450	1150	680	750	380	5.5	RT+5-600	±5%
YR0T2	750	600	600	1350	830	900	380	6.5	RT+5-600	±5%

4. Operation

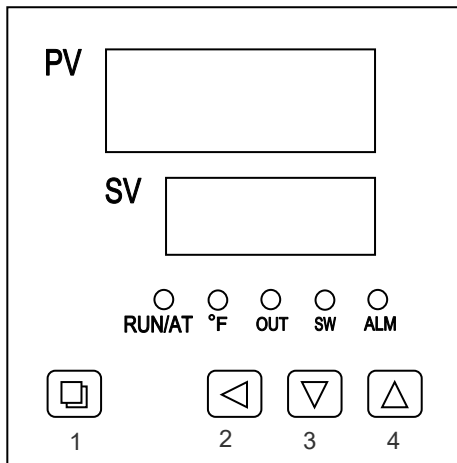

Indicator definition:

1. "RUN/AT" indicator: when running, this light is lit, the end of the regular time to extinguish; self timer, the lights flashing
2. "OUT" indicator light: when heating output, this light is lit, and on the contrary, it goes out
3. "ALM" indicator: there is a temperature deviation alarm or abnormal temperature measurement, this light is lit, there is a temperature deviation warning, this light flashes, and otherwise extinguished
4. "" indicator light: when the unit of temperature is Fahrenheit, the lamp lights up and turns off
5. "SW" indicator: reserved, invalid

- 1. setting 2. Shift / self identification
- 3. Reduce / rerun 4. increase

Operation and use method:

1. meters, the upper display display window "indexing and instrument models", "row display version number" after about 2 seconds into the normal state.
2. temperature and time reference and setting
 - 1) if there is no timing function:

Click the "set" button, enter the set temperature, the display window on the display prompt "SP", lower display setting temperature, can be reduced by shifting, increase key modifications to the desired set value; then click "setup" button to exit the setting state, the set value automatically save changes.
 - 2) if there is a timer function

Click the "set" button, enter the set temperature, the display window on the display prompt "SP", lower display setting temperature, modification method ibid; then click the "set" button, enter the time to set state, the display window on the display prompt "ST", the lower display time set value; then click the "set" key to exit the setting state, modify the set value automatically saved.

When the time is set to "0", said there is no timing function, instrument continuous operation, the display window shows lower temperature setting value; when the setting time is "0", the display window shows lower running time, "Fu said" light, start time, "Fu said" flashing time, running time the end of the display window, the lower display "End", the buzzer interrupted EST seconds (see the tweet internal parameter table -2) after stop singing. From time to time after the end of the run, according to the "reduce" button for 3 seconds to start running.



Explanation: for type PC-C6000 meters, the term "symbol" is "time unit";

For the PC-E6000 type instrument, "Fu said" to "lower display of a decimal point.

3. abnormal alarm of temperature measurement value

If the display window on the display, "said temperature sensor fault or temperature exceeds the measuring range or instrument failure, the instrument automatically disconnect the heating output, buzzer sound, alarm lamp lit, please carefully check the temperature sensor and wiring.

4. error over temperature alarm, buzzer beep, beep beep, ALM alarm lamp lit, disconnect the heating output; deviation over temperature alarm, buzzer beep, beep beep, "ALM" alarm lights; if due to the change of temperature setting value and over temperature alarm, "ALM" alarm lamp lit, but the buzzer sounds.

5. when the buzzer calls, press any key to mute

6. "shift" key: in the set state, click this button to make the setting value shift, flicker, modify; in the normal display state, long press this button for 6 seconds, you can enter the temperature self-tuning selection state

7. "reduced" button: click this button in the setting of the set value decreasing, press this button to set the value of continuous decline; in the normal display state, when the time after the end of the run, press this button for 3 seconds to start running.

"8. increase" button: click this button in the setting of the set value increasing, press this button to set the value of continuous increasing; in the normal display state, for the PC-C6000 type instrument, click this button to switch the LCD backlight.

System self-tuning

When the temperature control effect is not ideal, the system can be adjusted automatically. During the self setting process, the temperature will be greatly overshoot. The user should take full account of this factor before making the system self-tuning

Set state long press "shift" button for 6 seconds after entering the system self-tuning state in the upper display self-tuning prompt "AT" into the show "oFF", click "add" or "reduced" button to select "on" or "oFF", "on" is displayed in the, click on the "set" button, the instrument into the system self-tuning state [AT] indicator light flashes, self tuning is completed, [AT] stop flashing lights, PID controller will get a better, parameters automatically saved in the system. The auto tuning process in long press "shift" button for 6 seconds after the suspension tuning procedures.

In the system of the auto tuning process if there is deviation over temperature alarm, ALM alarm lamp is not lit, the buzzer is not sound, but heating alarm relay will automatically disconnect. In the system in the process of setting the "set" button is invalid. In the system tuning process regardless of whether there is constant time setting controller, display window always shows the lower temperature setting value.

Reference and setting of temperature internal parameters

Press the set button for about 3 seconds, the instrument display window on the display the password prompt "Lc" row display password value, by increasing, decreasing and the shift key, to modify the password required value. Then click the settings button, if the password value is not correct, the instrument can automatically return to normal state, if the password is correct. Then into the temperature parameters, click setting key again can modify various parameters. Then press the set button for 3 seconds, can exit the state parameters automatically saved as shown in the table below:



Internal parameter table -1

Parameter indication	Parameter name	Parameter function description	Factory default (range)
Lc	password	when“Lc=3” can view and modify parameter values	0
ALH	Up deviation alarm over temperature	when“Temperature measurement value > temperature setting value +HAL”, There is a deviation over temperature alarm (see 五.4) .	(0~100.0°C) 20.0
ALL	Lower deviation overtemperature alarm	when“Temperature measurement value < temperature setting value -ALL”, There is down deviation over temperature alarm (see 五.4)。 explain: when“ALL=0”, False alarm is invalid。	(0~100.0°C) 0
P	proportional band	Time proportional action regulation .	Note 1
I	integration time	Integral action regulation	(1~2000 second) 200
d	rate time	Differential action regulation	(0~1000 second) 200
T	control cycle	Heating control cycle	(1~60 second) Note 2
Pb	Measuring temperature deviation correction	It is usually used to correct the errors produced by cryogenic measurements Pb= actual temperature values - instrument measurements.	(-50.0~50.0°C) 0
PL	Measurement of temperature slope correction	Often used to correct errors in high temperature measurements PL= 1000 * (Actual temperature - instrument measurements) ÷ Instrument measuring value	(-999~999) 0
Addr	postal address	Reserve, Invalid	(1~32) 1
Loc	Locked	0: Temperature or time setting can be modified 1: Do not modify the setting of temperature or time	(0~1) 0

note 1: CU50 type: (0.1~100.0°C) 20.0; the others: (0.1~300.0°C) 35.0

note 2: The control period of the relay output type instrument .the factory default 20 second, the others are 5 seconds

Internal parameter table -2



Parameter indication	Parameter name	Parameter function description	Factory default (range)
Lc	password	when“Lc=9” View and modify parameter values	0
ndA	Temperature alarm mode	0: Only temperature deviation over temperature alarm; 1: At the same time there are temperature, down deviation, over temperature alarm;	(0~1) 0
ndc	temperature control	0: Fuzzy PID control; 1: stepping control	(0~1) 0
dE1	stepping control deviation	when“Temperature measurement value>temperature setpoint+dE1”, Turn off heating output; when“Temperature measurement value<temperature setpoint-dE2”, Turn on heating output. explain: This parameter is valid only when it is in stepping control.	(0~100.0°C) 0
dE2	stepping control lower deviation		(0~100.0°C) 0
ndT	timing mode	0: No timing function; 1: Constant temperature timing; 2: Boot timing	(0~2) 1
Hn	Constant temperature timer	0: Minute timer; 1: Hour timer	(0~1) 0
SPd	Constant temperature deviation	when“Temperature measurement value≥temperature setpoint-SPd”, enter into a state of constant temperature	(0.1~100.0°C) 0.5
SPT	Constant temperature Prompt time	When entering a constant temperature, the buzzer prompts the time. note: when“SPT=9999”, Permanent prompt.	(0~9999 second) 0
EST	Time end prompt time	When the timer is over, the buzzer indicates the time. note: when“EST=9999”, Permanent prompt.	(0~9999 second) 60
EH	whether the timer end up with constant temperature control	0: Turn off heating output at the end of the timer; 1: Continue the constant temperature control after the end of the timer.	(0~1) 0
ndo	Switch output mode	0: At the end of the timer, there is a switch output; 1: Over temperature alarm, there is a switch output; 2: When starting the constant temperature timing, there is a switch output. Note 3	(0~2) 1
oPn	Gating function	0: Close the door and judge the function; 1: Open the door and judge the function. Note 4	(0~1) 0



nP	maximizing power output	Maximum power percentage of heating output	(0~100%) 100
Co	Turn off heating output bias	when "Temperature measurement value \geq temperature setpoint + Co", Turn off heating output. Description: this parameter is valid only when PID is in control	(0~100.0) 50.0
SPL	Minimum temperature setpoint	Minimum value of temperature setting	Note 5
SPH	Maximum temperature setting	Maximum value of temperature setting	Note 6

note 3: Only model PC-6201 (solid state relay with switching output) of the instrument to have this function, there is a switch output refers to the relay normally open point closed

Note 4: To avoid false positives, choose a closed door opening function for a system that does not need to open the door to judge or cool down very quickly.

Note 5: PT100 type: (-50.0~50.0°C) 0; the others: (0~50.0°C) 0

Note 6: PT100 type: (SPL~400.0°C) 300.0; CU50 type: (SPL~100.0°C) 100.0;
E/K type thermocouple: (SPL~600.0°C) 300.0;

Internal parameter table-3

Parameter indication	Parameter name	Parameter function description	Factory default (range)
Lc	password	when "Lc=27" View and modify parameter values	0
Fc	Temperature e unit	0: degree Celsius; 1: Fahrenheit degree	Note 7

Note 7: PT100/CU50 hot resistance: (0~1) 0; E/K type hot resistance: (0~0) 0;

Internal parameter table -4

Parameter indication	Parameter name	Parameter function description	Factory default (range)
Lc	password	when "Lc=567" View and modify parameter values	0
rST	Factory Reset	0: cancel factory reset; 1: Confirm recover factory reset.	(0~1) 0

5. Troubleshooting

Trouble	Failure analysis and solutions
11.The equipment fails to work after power is connected	* there is something wrong with power , ask an electrician for help * heating wire burned out, test the two end resistance value of heat ware ,if resistance value is 0 , It means that the heating wire is short-circuit , it occurs switch trip ; if the resistance value is hundred Kohm or infinity ,it means that heat ware is open circuit power switch blade is off The power switch is on ,check the control circuit board and cable
2.temperature stops rising	* Check timing whether it is timing settings; * Most users do not understand the function, when reaches timing value, the heating wire stops working, the fan fails to work, temperature stops increasing .



	<p>* Check whether the fan is working , if fails (use multi-meter to test the voltage of fan pin whether it is 220V), then call us to send accessories to solve</p> <p>* Checking control panel with a multi-meter to see whether there is output, according to the drawing; (Drawings attached).</p>
3.motor fails to run	Result : it is running, but the airflow is unable to circulate ,lead to temperature rises slowly ,then contact us
4.handle is broken	Replace and contact supplier
5.there are differences between the temperature which panel displays and mercury temp.	<p>premise:</p> <p>Thermometer need to be tested whether it is qualified then to measure</p> <p>The installation position of mercury :hang the thermometer in the center of chamber ,avoid putting on the shelf to measure</p> <p>Refer to the parameter adjustment table</p>
6.temperature appears bounce or keep stationary ,or abnormal "----"	<p>* there is something wrong with temperature sensor , should to be replaced .</p> <p>Note : sensor adopts Pt100 platinum resistance</p>

6.Wiring diagram

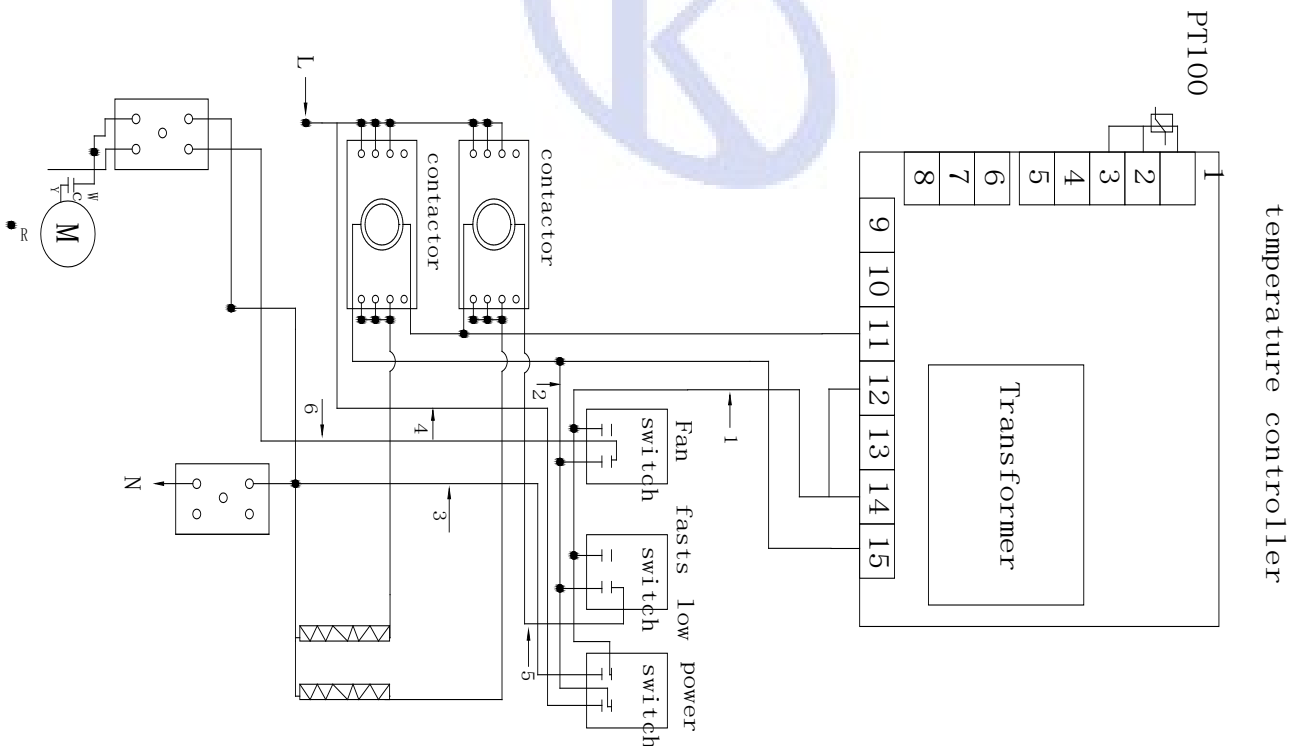

7. Notice

1. The samples should not be placed too crowded, so as not to affect convection inside the chamber.



Please connect the oven with protective conductor terminal according to relevant regulations. in

order to be safe, don't touch electrical circuit which is in the left oven with hand and wet cloth

2. Don't splash water to observation door, or it may crack
3. Don't use this kind of oven to dry inflammable, volatile and explosive substance, or it may cause explosion

8. Maintain

1. Drying oven should be kept clean, please use cotton cloth to clean glass door, in order to avoid chemical reaction , do not use corrosive chemical solution to sweep
2. If drying oven is not used for a long period, in order to avoid corrosion, should apply with neutral grease or Vaseline in the electroplating pieces. and placed in a dry indoors
3. Please operate this oven according to our manual, if there is something wrong with this oven, please refer to below solution

Packing list ↵

Name ↵	Quantity ↵	Remarks ↵
Drying oven ↵	1 ↵	↵
Shelf ↵	2 ↵	↵
English manual ↵	1 ↵	↵

↵