



Drying Oven

Series YR0171-1

# Instruction User Manual

Thank you very much for purchasing our Drying Oven Series YR0171-1.

Please read the “Operating Instructions” and “Warranty” before operating this unit to assure proper operation. After reading these documents, be sure to store them securely together with the “Warranty” at a hand place for future reference.



**Warning:** Before operating the unit, be sure to read carefully and fully understand important warnings in the operating instructions.



OUR SERVICES

## Benefits and Support

In Kalstein France, we take care of the full satisfaction of our customers, that is why we provide value-added services of the highest level based on our experience.



### Online Inductions and Trainings

In any part of the world, receive your induction or training from our specialized team of engineers



### Quick Response

Our work team is always available to response all your consults or questions, in order to support you in any situation.



### #Letsgivemore ♥

Thanks to your purchase, a donation will be made to a non-profit foundation that fights against breast cancer and helps most vulnerable communities.



### Technical Support

Enjoy of personalized advice for the correct preventive and corrective maintenance of your equipment, thanks to Kalstein's manuals and articles, special catalogues and video tutorials.



### Delivery Logistics

We take care of all the necessary logistics for the dispatch of your goods, whether is by sea, land or air.



### Kalstein Worldwide

With more than 25 years growing with our customers, Kalstein's multiformat and modern content, is now present in more than 10 countries and increasing.





## Table of contents

<b>I.</b>	<b>Scope of application .....</b>	<b>2</b>
<b>II.</b>	<b>Technical indexes .....</b>	<b>2</b>
<b>III.</b>	<b>Structural description .....</b>	<b>2</b>
<b>IV.</b>	<b>Method of use .....</b>	<b>3</b>
<b>V.</b>	<b>Precautions .....</b>	<b>4</b>
<b>VI.</b>	<b>Operating methods .....</b>	<b>4</b>
<b>VII.</b>	<b>Wiring diagram .....</b>	<b>8</b>
<b>VIII.</b>	<b>Failure handling methods .....</b>	<b>9</b>



## I. Scope of application

Apply to the drying, braking, wax melting and sterilization of the articles in industrial and mining enterprises, colleges and universities, scientific research and medical units, labs, etc.

## II. Technical indexes:

Drying oven								
Model:	YR0171-1	YR0171-2	YR0171-3	YR0171-4	YR0171-5	YR0171-7	YR0171-8	YR0171-9
Electrical Requirement:	220V 50HZ		220V 50HZ			380V 50Hz		
Temperature Range:	RT+10~200°C/RT+10°C~250°C							
Display Resolution:	0.1°C							
Temperature Stability:	±1°C							
Ambient Temperature:	+5~40°C							
Power Consumption:	850W	850W	1550W	2050W	2450W	3100W	4000W	5200W
Chamber Volume:	30L	50L	80L	136L	220L	420L	620L	1000L
Interior Dimension (W×D×H, mm):	340x320x320	420x395x350	450x400x450	550x450x550	600x500x750	640x585x1355	840x600x1355	1000x600x1600
Exterior Dimension (W×D×H, mm):	620×440×490	720×530×520	740x530x630	840×580×730	880×630×930	760×730×1780	980x800x1880	1140x800x2150
Shelves:	2(pcs)	2(pcs)	2(pcs)	2(pcs)	2(pcs)	3(pcs)	4(pcs)	4(pcs)
Timing range:	1~5999min				1~5999min			

## III. Structural description

Drying Oven Model forced air drying cabinet includes serial products. They are divided into two categories in appearance: desk-type and vertical-type. The desk type has a relatively smaller capacity, including three types of specifications: 30L, 70L and 120L. The vertical type has a relatively bigger capacity, including 200L, 420L and 620L. The shells of drying cabinets of all specifications are made of excellent steel plates and the surfaces have baking varnishes. The working room is made of stainless steel plates and has 2~5-layered shelves made of stainless steel wires (the middle layer is filled with extra-fine glass wool for insulation). The desk-type cabinet door adopts dual-layer tempered glass door; the vertical cabinet door has dual-layer glass viewing window in the top middle, through which the heating articles in the cabinet can be clearly observed. The connection between the working room and the cabinet door is installed with heat-resistant silicone rubber sealing ring in order to guarantee the sealing between the working room and cabinet door. The power switch, power indicator light, air door adjusting knob, temperature control instrument and other operating parts of drying cabinet are all located on the control panel in the front of cabinet body. For the desk type, the control panel is on the front left side of cabinet body; for the vertical type, it is on the front top side of cabinet body.

The heating constant temperature system in the cabinet mainly consists of motor with centrifugal impellers, electric heater, proper air duct structure and temperature control instrument.



When switching on the drying cabinet, the motor rotates and vent upwards the heat produced by the electric heater (at the bottom of the cabinet) through air duct, which is absorbed into the fan after going through the articles to be dried in the working room. Such circulation continues until the temperature becomes even.

The temperature control instrument is a universal-purpose part made meticulously by our company. It is featured by the following functions: precise temperature control; the set temperature and the temperature in the cabinet are digitally displayed; the set temperature has protective device and tracking alarm. When the temperature in the cabinet is 10°C higher than the set temperature, the tracking alarm will switch off the power supply of the heater and send out the sound and light alarms.

Air door regulator can regulate the air inflow and outflow of the cabinet by starting up the air door adjusting knob.

#### **IV. Method of use**

1. Put the articles to be dried into the drying cabinet, close well the door and turn the air door adjusting knob to “ ∑ ” position.
2. Move the power switch to “ON”. The power indicator light lights up and figures appear on the temperature control instrument.
3. Press and hold the temperature adjusting knob of temperature control instrument, the numeric temperature displayed at the moment is the set temperature. At the same time rotate the knob to select the required set temperature. When loosening the knob, the numeric temperature displayed at the moment is the temperature in the cabinet and the heating indicator light lights up, showing that the instrument has been in the heating and temperature-rising state. After a period of time, when the displayed temperature is near to the set temperature, the heating indicator light is flickering for many times. Under usual conditions, after heating for 90 minutes, the temperature control will be the constant temperature state.
4. When the required working temperature is lower, adopt the two-stage set method. For example, if the required temperature is 80°C, first set 70°C and after the overshoot temperature starts to drop back, then set 80°C, which can reduce and even eliminate the phenomenon of overshoot temperature, thus enable the inside cabinet to attain the temperature-constant state as early as possible.
5. Select the different drying times according to the different humidity of different articles, e.g., the articles to be dried are more humid, turn the air door adjusting knob to “ ≡ ” position so as to vent the humid air in the cabinet.
6. When the drying process being over, if not to immediately take the articles out, first turn the air door adjusting knob to close the air door, or let open the air door and move the power switch to “OFF”, then opening the cabinet door immediately to take out articles, but take care not to be scalded.

#### **V. Precautions:**

1. The shell of the drying cabinet shall be well grounded to guarantee the safe use.
2. The drying cabinet shall be placed inside one well-ventilated room, surrounding which no



inflammable and explosive articles are available.

3. The drying cabinet has no explosion-proof device, so never place inflammable and explosive articles inside for drying.

4. The articles in the cabinet shall not be too crowded. Certain space shall be left so as to facilitate the circulation of hot air.

5. Always keep the internal and external of the cabinet clean. In case it will not be used for a long time, please cover it with a plastic thin film dirt shroud and put it in a drying room.

## VI. Operating methods

### 1. Energization to start up

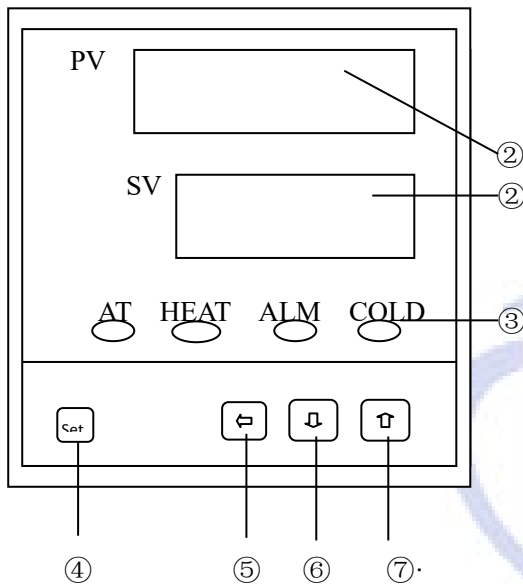

①PV display unit (Red)

·Displays measured value or the various characters depending the statue of the instrument

②SV display unit (Green)

·Displays the set value or the timing and rated parameters

③Indicators

·share AT working incubator (green) and TIME of light when ST=0and light is on,mean not use timing;flashes d uring auto-turning execution or ST=0mean self-turning  
HEAT heating output lamp (green) It shines when working for output.

ALM alarming indicator(Red),turned on

(Note: COLD cooling function)

④Function key

·Used for displaying the change and confirm of the parameters

⑤shift key

shifting the set value or observing

⑥and ⑦ Add or Subtract key for changing the digital code and/or the key to express entering the auto-tuning state

·Used for adjusting the digital code displayed or entering the auto-tuning state

### ◆ Sequence to pick up the functions of the instrument

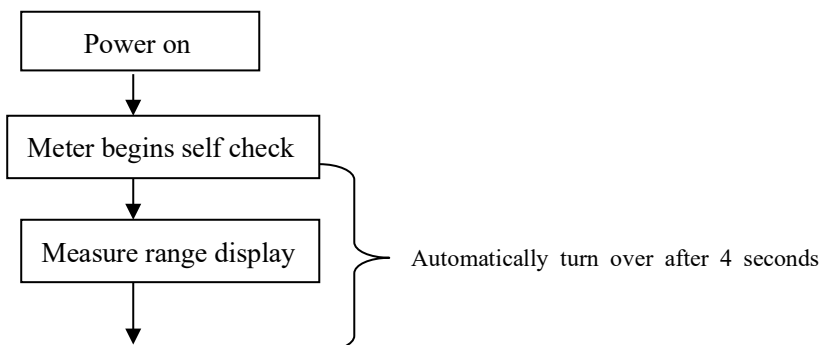

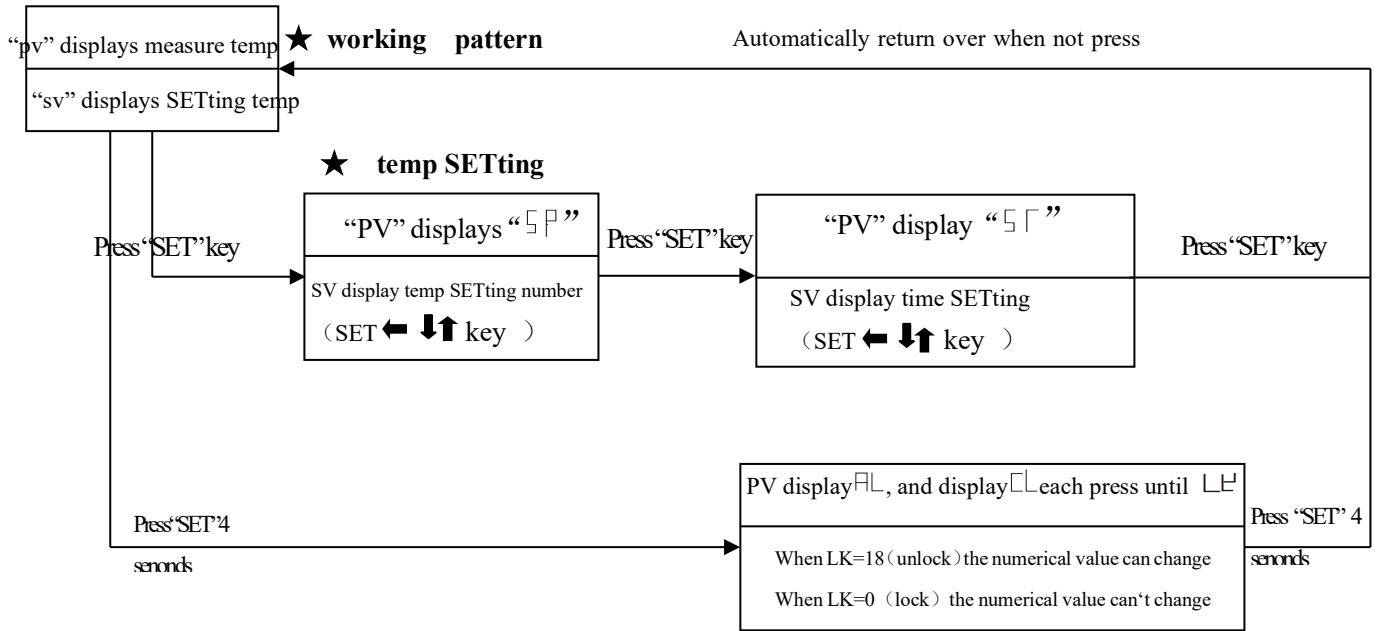

★  $\overline{LE}$  is code lock,  $\overline{AL}$   $\overline{CL}$ ...meanings please check sheet “8 Page”

◆ **The detail description for every function**

- If upper row displays “OVER” the sensor is in open circuit or the input signal exceeds the range of measurement.

- The method for changing set value:

1. Press set key the upper row displays SP. Press  $\overline{\downarrow}$  or  $\overline{\uparrow}$  key, the low row displays the needed value. Again press the upper row displays set key, press  $\overline{\uparrow}$  or  $\overline{\downarrow}$  key, the lower row displays the timing time needed. Again press key, the instrument return to the standard display mode.

2. Set the temperature at 150°C. The heating indicator lamp is on, indicating the entry into the heating-up state. A while later, as the displayed temperature is close to the set value, the heating lamp is repetitively on and off for many times. Generally speaking, the temperature will become constant after being heated for 90 minutes.

3. If the required working temperature is rather lower, the method of secondary setting can be adopted. For example, f the required working temperature is 70°C, first set the temperature at 60°C, then wait till the temperature to begin to fall, and further set the temperature at 70°C, thus decreasing or even eliminating the temperature overshoot and entering into the constant temperature state as soon as possible.

- Timing function

1. When the value of St is setting to zero, the timing function is canceled. Otherwise when the value of is St not setting to zero the timing function is available. (timing function range:1-9999 minute)





Timing resume: set  $\overline{\uparrow}$  until the instrument entering the working mode, and run



according to the setting time before.

2. When the power is turned on the timing function starts. In case of achieving the setting timing the heating output is close, and the buzzer sounds four times to notice the operator. But the refrigeration output is working continuously. When the system is starting with auto tuning, the timing function is also canceled. When the auto tuning process is completed, the timing function would start again. During the operating period of the instrument, it is allowed to update the value of St online, and the time passed can be memorized and the instrument will operate the updated timing time. When the updated time is less than the passed accumulative time, the heating output close immediately, the buzzer sounds 4 times. The refrigeration output is working continuously.

● The method for changing control parameter:

. After press set key over 4 seconds, find LK. Then press  or  key to the lower displayer display 18. Again press the set key to find the symbol character for the needed parameter. Through, press the key  or  till the high row displays display the parameter needed is reached. Some parameters may be setting at once. After 30 seconds, the instrument returned to the standard mode. If no key is press down the instrument return to its standard mode after 1 minute.

◆ **The function of the controller Auto-tuning:**

1. After pressing  /TIME key, the instrument displays the time have been operated.

2. After pressing  /AT key 20 seconds the AT indicator flashes and the auto-tuning process starts; after the end of auto-tuning the AT indicator then be turned out. A set of PID parameters can be got automatically for overcoming temperature overshoot. The controller operates according to this set of PID parameters is working continuously.

3. In the period of auto tuning, if press  /AT key beyond 20 seconds the AT indicator turns out and the auto tuning process is canceled. The instrument operated according to the original PID parameters.

◆ **Following table lists the function parameters:**





Symbol	Name	Setting range	Description	Factory set value
AL/AL	Alarming setting	0-Full Range 0.0-Full Range	When temperature is beyond SP+AL, the ALM indicator turns on. The buzzer sounds and the heating power turn off.	
CL/CL	Refrigeration control setting	0-Full Range 0.0-Full Range	When the temperature less than SP+COL, the refrigeration point is turn on to drive the compressor.	<b>without this function</b>
CT/CT	Refrigeration control delay	(0~3600) s	When measured value reaches to alarm value, the alarm relay will not output before it passes CT time.	<b>without this function</b>
P/P	Proportional Band	1-Full Range 1.0-Full Range	Proportional control action. If P is larger, then the gain of system is lower. It only use on the heating side.	
I/I	Integral Time	0-3600 seconds	Integrated time constant. I larger, then the integrated action is smaller.	
D/d	Derivative Time	0-3600 seconds	Derivative time constant. D larger, then the derivative action is also larger D can overcome overshoot. I=0 and D=0 is called half proportional control.	
Ar/Ar	Overshoot Control(re-setting)	1-100%	At on-off PID control, the value of Ar is a constant which equals 1.5-2times of the ratio of on time to the on-off period in the equilibrium state, In the half proportional control, the Ar equals coefficient/P.	
T/T	Heating period	1-300seconds	For the thyristor output, it is about 1-3seconds. For those equipments that the superfluous power provided is comparatively larger, select larger T would decrease the stable error caused by PID control.	
Pd/Pb	Zero point adjust (intersection)	-100-100 -100.0-100.0	When the zero error comparatively smaller and the full point error comparatively larger, to update this value should be needed. Ordinary for pt100, updating this value is rarely needed.	
Pf/PK	Full point adjust(intercept)	-1000-1000 seconds	When the zero error comparatively larger and the full point error also comparatively larger, to update this value should be needed. PK=4000×(setting value-actual value)/actual value. For pt100 adjusting this value is need at first time.	
/FN	fan control	0~100	When set to 0, the low fan work when set to 50, mid-range fan work when set to 100, the work of high-grade fan.	
LK/LK	Password key	0-255	When LK=18 the parameters listed above then the above parameters can be updated.	



## VII. Wiring diagram

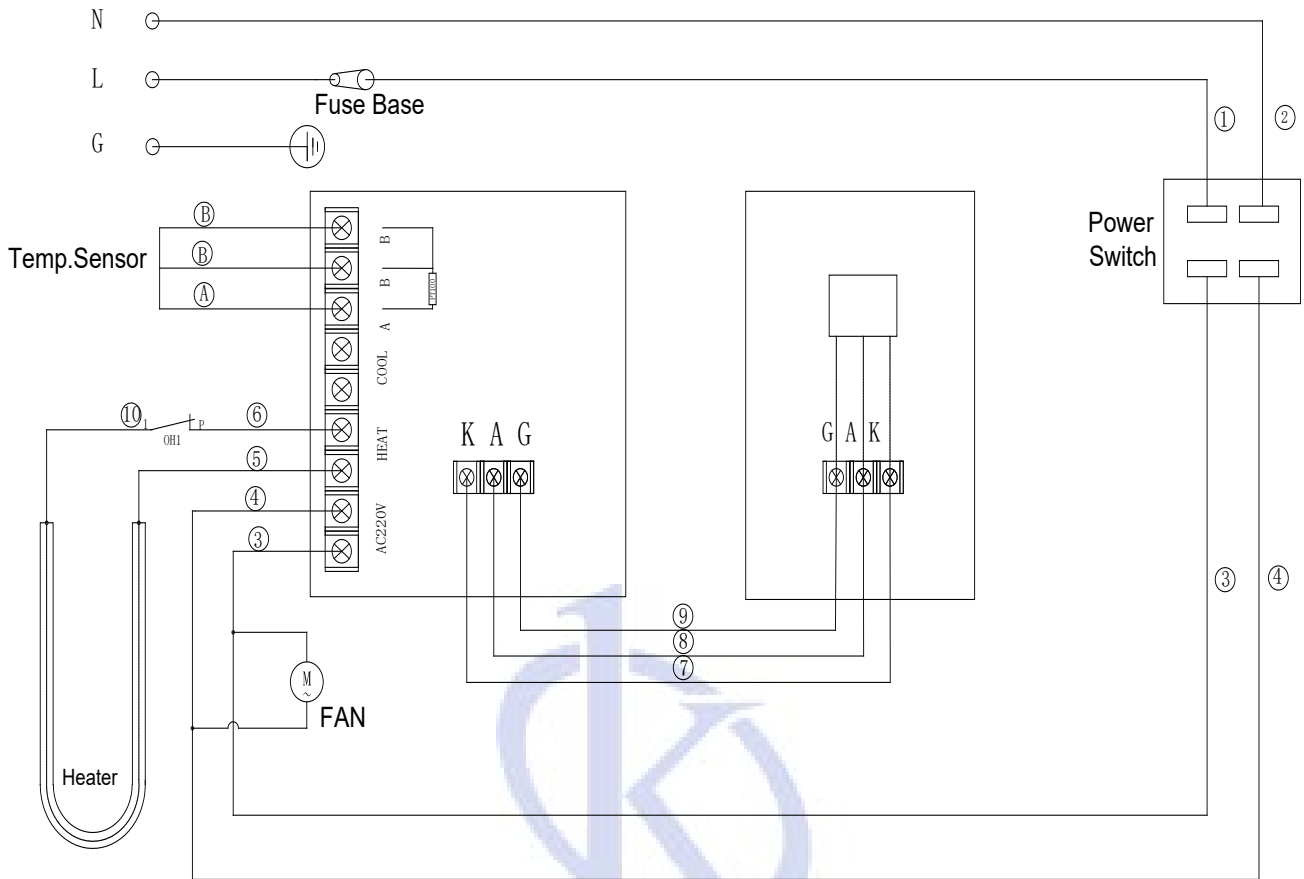



### VIII. Failure handling methods

Problems	Causes	Handling methods
1. No supply	1. The plug is not inserted well or the wire is disconnected.	1. Insert the plug and connect the wire.
	2. Fuse is open.	2. Replace the fuse.
2. The temperature in the cabinet does not increase.	1. The set temperature is low.	1. Adjust the set temperature.
	2. The electric heater does not work.	2. Replace the electric heater.
	3. The temperature control instrument does not work.	3. Replace temperature control instrument.
	4. The cyclic fan does not work.	4. Replace the fan.
3. The set temperature has a big difference from the temperature in the cabinet.	1. The temperature sensor does not work.	1. Change temperature sensor.
	2. The fine tuning potentiometer for setting temperature is not adjusted well.	2. Adjust the potentiometer.
4. The temperature alarming abnormal.	1. The set temperature is low.	1. Adjust the set temperature.
	2. The temperature control instrument does not work.	2. Replace the temperature control instrument.

### Packing list

No.	Type	Name	Unit	Qty.	Remarks
1	Document	Operating instructions		1	
2	Document	Packing list		1	
3	Spare part	Shelf		3	



All rights reserved © KALSTEIN France S. A. S.,  
 Optimum Business Center 450 Rue Baden Powell,  
 • 34000 Montpellier, France.  
 Tlf: +33 467158849 / +33 680760710 / +33 663810023  
<https://kalstein.eu>  
**KALSTEIN FRANCE, S. A. S**

