

Combined Refrigerator & Freezer

Model YR05320

Instruction Manual

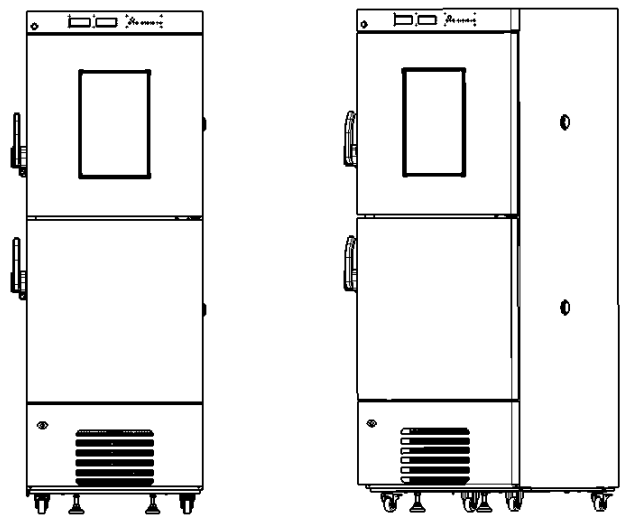

Thank you very much for purchasing our Kalstein's Combined Refrigerator & Freezer Model YR05320.

Please read the "Operating Instructions" and "Warranty" before operating this unit to assure proper operation. After reading these documents, be sure to store them securely together with the "Warranty" at a hand place for future reference.



Warning: Before operating the unit, be sure to read carefully and fully understand important warnings in the operating instructions.



OUR SERVICES

Benefits and Support

In Kalstein France, we take care of the full satisfaction of our customers, that is why we provide value-added services of the highest level based on our experience.



Online Inductions and Trainings

In any part of the world, receive your induction or training from our specialized team of engineers



Quick Response

Our work team is always available to response all your consults or questions, in order to support you in any situation.

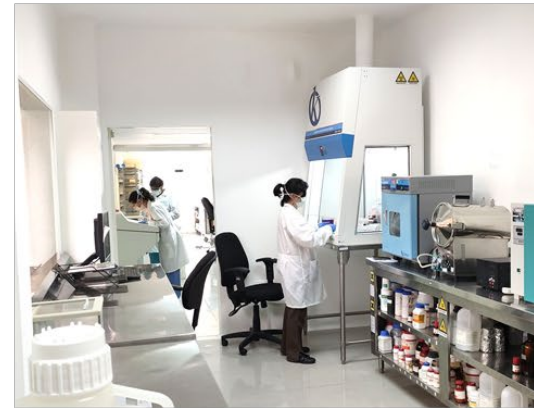

#Letsgivemore

Thanks to your purchase, a donation will be made to a non-profit foundation that fights against breast cancer and helps most vulnerable communities.



Technical Support

Enjoy of personalized advice for the correct preventive and corrective maintenance of your equipment, thanks to Kalstein's manuals and articles, special catalogues and video tutorials.



Delivery Logistics

We take care of all the necessary logistics for the dispatch of your goods, whether is by sea, land or air.



Kalstein Worldwide

With more than 25 years growing with our customers, Kalstein's multiformat and modern content, is now present in more than 10 countries and increasing.





CONTENTS

I. Product Features.....	5
II. Name of Components.....	6
III. Cautions on Safety.....	6
IV. Cautions on Transporting.....	9
V. Cautions on Use.....	9
VI. Installation.....	10
6.1 Installation Environment.....	10
6.2 Cautions.....	11
6.3 Installation Site.....	11
VII. Use.....	11
7.1 Installation.....	11
7.2 Grounding.....	12
7.3 Adjustment.....	12
7.4 Cautions.....	12
7.5 Forbidden.....	12
7.6 Operation after Cutting off Power Supply.....	13
VIII. Temperature Adjusting and Setting.....	13
8.1 Functions of Buttons.....	13
8.1.1 Time query settings.....	15
8.1.2 Alarm code.....	15
IX. Daily Maintenance.....	16
9.1 Clean the Storage Cabinet.....	16
9.2 Internal Wall Defrosting.....	16
X. Trouble shooting.....	16



XI. Abandoned Equipment Treatment.....	17
XII. Technical Data	18
12.1 Main technical parameters	18
12.2 Electric Circuit Diagram.....	18
XIII. Packaging List	14





I. Product Features

- Microcomputer digital thermostat, temperature is adjustable ranging 2°C~8°C / -10°C~-25°C.
- Diversified protection functions (compressor time delay protection, compressor high temperature protection) .
- The product is mainly used for storing blood plasma, biological materials, vaccine, electronic devices and low temperature test for special materials etc.
- It is applicable for the laboratory of blood bank, hospital, quarantine station, university, scientific research institute, electronic chemicals etc.
- Convenient for storing and taking with multi-layer and independent closed storage space.

Due to the improvement and various models of products, the actual product may be different from the diagram, please in kind prevail!

- Please see the real product for the appearance, color or pattern of the storage cabinet
- It is not allowed to use this storage cabinet for storing live animals and fresh flowers which have strict requirements on temperature



II. Name of Components

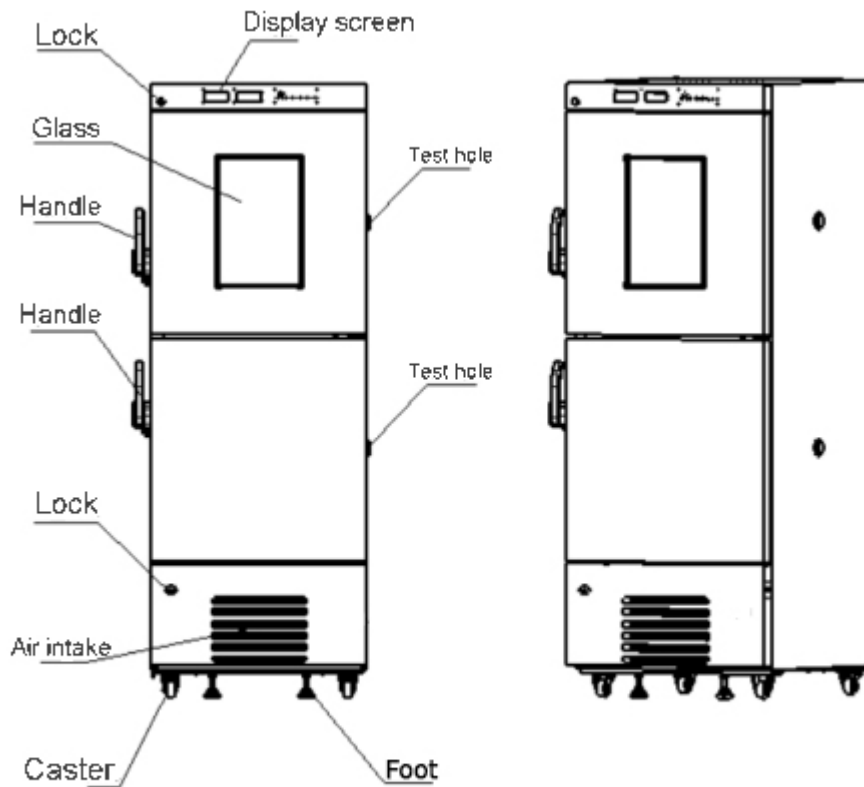

III. Cautions on Safety

- This User's Manual lists out the important safety regulations, please follow the safety regulations, otherwise, the consequences shall be undertaken by you.
 - Please follow the cautions and regulations listed in this User's Manual for avoiding possible injury for the operator and any other.
 - "Caution", "Forbidden" and "Warning" are shown as below:
- !** Items marked with "Warning" are related with the safety of the product and operator, and should be strictly followed.
- ⊘** Items marked with "Forbidden" must absolutely be forbidden, otherwise, it may possible cause damage for the storage cabinet or physical safety for the operator.



⚠ This mark is marked on the cover of high voltage electric appliance for avoiding electric shock, and this cover should be removed by qualified engineer or repair technician.

- ❖ **ⓘ** Please adopt the special power supply (AC 220V60Hz) listed on the name plate of the equipment. If the voltage is lower than 187V or higher than 242V, please install the 4000W or higher automatic voltage stabilizer for the product. If the power cord should be extended, it is necessary to use copper core wire above 2.5mm², and the cross section area of copper core wire in the wall connected with the power outlet must also be guaranteed to be above 4mm², and the length should not be longer than 3m. It may possibly cause fire or electric shock if power supply of different voltage or frequency which are not marked on the name plate is used.
- ❖ **ⓘ** The power cord of the storage cabinet has 3-line (grounding) plug, and standard 3-line (grounding) socket. Please do not cut or remove the grounding pin of the power cord under any condition. Please ensure that the plug of power cord tightly inserts into the socket with tight contact, otherwise, it may possibly cause fire.
- ❖ **ⓘ** Please use power socket which is connected with grounding wire for avoiding electric shock. If the power socket is not connected with the ground, please ask the qualified technician to install grounding wire.
- ❖ **ⓘ** It requires installing independent overload and leakage protector at the power supply terminal of this storage cabinet.
- ❖ **⊘** Do not drill on the surface of the storage cabinet, otherwise, it will seriously influence the cooling performance of the storage cabinet.
- ❖ **⊘** Do not connect this equipment with the ground through gas pipe, water pipe, telephone wire or lightning rod because above mentioned grounding will cause electric shock or other dangers.
- ❖ **⊘** Do not use the equipment in the open air. It may possibly cause electric leakage or electric shock if the storage cabinet is wet with rain.
- ❖ **ⓘ** This equipment should only be installed by qualified technician, it may possibly cause electric shock or fire if it is installed by disqualified technician.
- ❖ **ⓘ** Please install the equipment on the solid floor, if the floor is not solid or the installation place is unsuitable, it may possible cause equipment overturn or physical injury.
- ❖ **⊘** Do not install the equipment in the damp site or place where may easily suffer from water, otherwise, it may cause electric leakage or electric shock since the insulating quality will be dropped.
- ❖ **⊘** Do not store flammable, explosive and dangerous products or volatile materials in the equipment, do not use flammable mist near the equipment, otherwise, it may possibly cause explosion or fire.
- ❖ **⊘** Do not store acid, alkali and corrosive materials in this equipment, otherwise, it may possibly damage the internal components or electric parts of the equipment.



- ❖ ⦿ Do not insert metal products such as iron nail or wire into any hole and clearance of this equipment or any outlet for internal air circulation, otherwise, it may possibly cause electric shock or physical injury since the above objects may contact with the moving parts.
- ❖ ⚠ Please use this equipment in the safe area when it is used for toxic, harmful or radioactive materials since incorrect use may possibly cause harm to human health the environment.
- ❖ ⚠ When there's flammable gas leakage, please turn off the gas valve, open the doors and windows for ventilation, please do not unplug or insert the power plug of the storage cabinet.
- ❖ ⚠ Please cut off power supply before equipment repair or maintenance for avoiding electric shock or physical injury.
- ❖ ⚠ Ensure that the repair technician won't inhale medicine or suspended particles in or surrounding this equipment, otherwise, it may possibly cause harm to human health.
- ❖ ⦿ Do not directly pour water on the equipment, otherwise, it may cause electric shock or short circuit.
- ❖ ⦿ Please do not disassemble, repair or refit this equipment by yourself. Any above work which is not operated by the authorized technician may possibly cause fore or physical injury.
- ❖ ⚠ If the equipment doesn't work normally, please cut off power supply. It may possibly cause electric shock or fire if it keeps working under abnormal state.
- ❖ ⚠ If the equipment is kept in the open area for a long period, please ensure that children won't approach the equipment, and the cabinet door should not be closed completely.
- ❖ ⚠ Please do not supply power within 5 minutes if the power supply of the storage cabinet is cut off, otherwise, it may possibly damage the compressor or system, please unplug the power plug before repairing the equipment. Please do not roll, press or damage the power cord.
- ❖ ⚠ The abandoned equipment shall be handled by corresponding technician. Remove the cabinet doors for avoiding accident such as suffocation.
- ❖ ⚠ Please hold the power plug instead of pulling the wire of plug when removing the plug from the power socket, otherwise, it may possibly cause electric shock or fire caused by short circuit.
- ❖ ⦿ Please do not contact any electric part or switch such as power plug with wet hand, otherwise, it may possibly cause electric shock.
- ❖ ⚠ When restart the equipment after power failure or cutting off power supply, please check the settings of the equipment because the change of settings may possibly damage the stored materials.
- ❖ ⦿ Please do not put the container with water or heavy object on the equipment, otherwise, it may possibly cause physical injury if the object falls down, and the water may drop the insulation quality and result in electric leakage or electric shock.



- ❖ ⊘ Please do not climb on the equipment or put other objects on the equipment, otherwise, it may possible cause physical injury or equipment damage if the equipment turns over.
- ❖ ⊘ Please do not store the glass bottle or filling container in the cabinet, otherwise, it may possibly cause physical injury if the container is broken under low temperature.
- ❖ ⊘ Please do not directly contact the stored materials with hand, otherwise, it may possibly cause frostbite if hand contacts the frozen material or internal wall of the equipment.
- ❖ ⚠ Please wear gloves when repairing the equipment for avoiding injury caused by the sharp edge or corner.
- ❖ ⚠ If the equipment won't be used for a long period, please unplug the power plug for avoiding electric shock, electric leakage or fire caused by aging power cord.
- ❖ ⊘ Keep plastic bag out of reach of children because plastic bag may possibly cause suffocation.

IV. Cautions on Transporting

- **Please transport the storage cabinet with forklift or clip charter before unpacking.**
 - a. If forklift is used, please insert from the bottom of wood support at the side of the storage cabinet and then move the storage cabinet.
 - b. If the clip charter is used, please lift from the bottom of wood support, ensure clip the side of the storage cabinet.
- **After unpacking, please push the storage cabinet for moving it.**
- ⚠ **Note: Please do not incline the storage cabinet by over 45° when transporting.**

V. Cautions on Use

- After installation, keep the device standing for 12 hours at least to return the compressor oil.
- After installation and first use testing, please adjust the castors to fix the device.
- When starting the storage cabinet for the first time or after stopping for a long period, please test the battery, it is possible that the battery is under low power because the battery has been safely discharged, it doesn't mean that there's fault. Under this condition, please fully charge the battery, and keep the storage cabinet working continuously for about 10 hours.
- When the storage cabinet is working, the door frame of the cabinet may be hot, and it is not fault. In order to prevent dew on the enclosure, defrosting pipes are installed around the cabinet.
- Before storing objects in the storage cabinet, please confirm that the temperature has dropped in the cabinet, then put objects in it by batches for avoiding temperature rise.



- The temperature displayed is the temperature at the heat detector in the storing cabinet, although it is possible that there's difference between the displayed temperature and the actual temperature in the middle of the storing cabinet, it will gradually reach the real temperature.
- Please clean the equipment with diluted and PH-balanced detergent (undiluted detergent may damage the plastic parts. .Please refer to the instructions of detergent for diluting it). Do not clean the storage cabinet with brush, acid, gasoline, soap powder, polishing powder or hot water, because above materials may possibly hurt the coating surface and plastic and rubber parts. Please do not wipe the plastic and rubber parts with volatile solvent such as gasoline.
- After working for a period, frost may occur on the evaporator, if the frost is thick, it may influence the cooling effect of the storage cabinet and increase electricity consumption, therefore, please cut off power supply to remove frost when the frost is about 5mm thick.
- Before defrosting, please take out the objects from the cabinet and put the objects in the other chamber for avoiding damaging the objects when the temperature rises.
- There are a lot of cooling coils on the rack, please do not remove frost on the rack with sharp tools such as knife, ice chisel or screwdriver. When removing frost, please do not scratch the evaporating pipe, otherwise, it may cause equipment fault.
- If the storage cabinet won't be used for a long period, please cut off power supply and turn off the battery switch.
- In order to reach the best cooling effect, avoid frequently opening the first small door.

VI. Installation

6.1 Installation Environment

- Environment temperature: 10°C~32°C, do not exceed 32°C (keep below 28°C as far as possible for use. if the ambient temperature is higher than 32°C, the cooling efficiency will decrease rapidly, and the ambient temperature is higher than 32°C for a long time will probably lead to compressor damage or life reduction, therefore, the environment using this product is recommended to install air conditioning).)
- Environment humidity: <80% RH. It shall be lower than 57% RH if the highest work temperature is 32°C.
- Avoid too much dust.
- Avoid mechanical sway or vibration.
- Work Elevation: <2000m.
- Input Voltage: <220V±10%.



6.2 Cautions

- Because low temperature equipment is relatively sensitive to the environment temperature. If the equipment is installed in other environments and can't work normally, please optimize the environment.
- It is not allowed to install the equipment in the open environment. It may possibly cause electric leakage or electric shock if the storage cabinet is wet with rain.

6.3 Installation Site

In order to ensure normal work and obtain best performance, the site for installing the equipment shall meet the followings:

- Do not install it in the small and closed space, the door of the room shall not be less than this product for avoiding difficult repair and storage objects damage when the equipment is fault.
- Leave at least 30cm gap at four sides of the storage cabinet for ventilation.
- The floor for installing the equipment must be smooth.
- The site shall be well ventilated without direct sunlight.
- Please do not share one socket with other equipment, ensure the plug and socket are connected tightly.
- Please do not twist or press the power cord.
- To extend the power cord, the specification of the wire should be 230V~, 15A.
- Please check the work voltage before use, take it into consideration to use voltage stabilizer in the area with unstable voltage for assuring to stabilize the input voltage at 220V-±10%, the power of the voltage stabilizer shall >3kW.
- Ensure reliable grounding for this equipment.
- If the power socket is installed with grounding wire, please check the grounding condition before use.
- If the socket is not installed with grounding wire, please install grounding wire by qualified technician.
- Please install the independent overload and leakage protector at the power supply terminal of the storage cabinet.

VII. Use

7.1 Installation

- a. Remove packing materials and packing bag

Remove all packing materials and packing bags.

- b. Install the position limiting sheet metal



Install the position limiting sheet metal at the rear side of the machine set.

7.2 Grounding



Warning

- Please use power socket with grounding wire. If the socket is not installed with grounding wire, please install grounding wire by qualified technician.
- Do not connect this equipment with the ground through gas pipe, water pipe, telephone wire or lightning rod because above mentioned grounding will cause electric shock.
- After installing, the power socket must be approachable for conveniently unplug the power cord in emergency. Do not cover the air outlet of the Freezer with any object.

7.3 Adjustment

Please refer to the following steps when use the equipment for the first time:

1. After installing the storage cabinet, please do not supply power within 24 hours.
2. When nothing is stored in the cabinet, connect the power cord with special socket of suitable specification.
3. If there's alarm sound, please press the SET button to stop alarm.
4. Set the desired storage cabinet temperature: when nothing is stored in the cabinet, supply power, start the cabinet, observe that the storage cabinet may start and stop normally for over 24 hours, which proves that the performance of the storage cabinet is normal.
5. After confirming normal performance of the storage cabinet, please store objects in the storage cabinet.

7.4 Cautions

- Please arrange full time technician to check and record the working conditions (record once every 2-4 hours), the temperature in the storage cabinet will rise if there's fault or the cabinet is stopped, please take out the objects if it can't be repaired in a short period, and move the objects to the place which meets the requirement on storage temperature for avoiding damaging the objects.
- Before storing objects in the cabinet, please confirm that the desired temperature shall be accordant with the temperature range of this product for avoiding damaging the objects and causing loss if the temperature of the product can't reach the requirement.
- As a result of cooling inertia, there's difference between the displayed temperature and the setting temperature of the product (the lower the setting temperature, the lower the temperature difference), which is normal.

7.5 Forbidden

- All Freezer are the storage equipment, it is not allowed to put too much and relatively hot objects into it, otherwise, it may cause



constant working of compressor and bad cooling effect, which may easily damage the compressor.

- Please do not accelerate the defrosting process with any mechanical tool or other mode which is not approved by the manufacturer.
- Do not damage the cooling loop
- Do not use the electric appliance which is not approved by the manufacturer in the storage cabinet.
- Notes: If there is indeed parameter change requirement, please contact the after-sale and distributors of us for setting.

7.6 Operation after Cutting off Power Supply

The storage cabinet has memory function for the setting value, after power off, the equipment will work according to the setting parameters before the last power failure.



VIII. Temperature Adjusting and Setting

8.1 Functions of Buttons

The temperature controller is installed on the control panel of the medical refrigerator. When power is on, the digital display screen can display actual temperature inside the refrigerator. The control panel is illustrated by the following diagram:

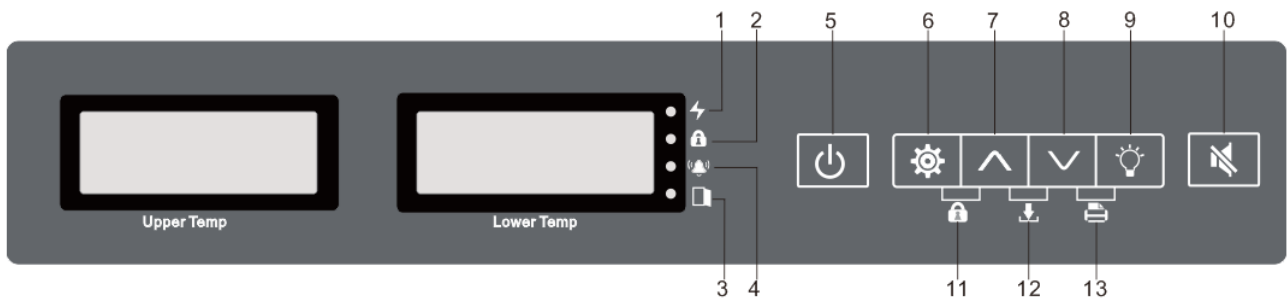

1.Power

2.Lock

3.Door's open

4.Alarm

5.power

6.Set

7.Up key

8.Down key

9.Light

10.Mute

11.Keyboard lock (Combination)

12.Data download key(Available when optional USB interface)

13.Printer(Combination) (Available when optional thermal printer)

- ❖ Under normal mode, press the setting key to enter the St parameter selection interface once, at this time, the left digital tube flashes to display the current temperature of the upper chamber, and the right side normally displays the current temperature of the lower chamber (at this time, select to adjust the upper chamber setting temperature).
- ❖ Select the St parameter that needs to be adjusted, press the setting key again, flicker to show the current setting temperature, then press the key to reduce the setting value 0.1, press the up key to increase the setting value 0.1
- ❖ After adjusting the set value, press the key, and the parameter is saved.
- ❖ If there is a special need to adjust, please call the after-sales service phone or by professional maintenance personnel to adjust. Adjust the set temperature at will, may cause the product high temperature (AH) or low temperature (AL) alarm, at this time, please adjust the high and low temperature alarm value (AH, AL) at the same time. Note: General high and low temperature alarm values



are in the set temperature ± 5 range.

8.1.1 Time query settings

Time setting is required to ensure accurate power-on of printed and recorded data.

Code	Display	Max	Min	Unit	Defaults
SJ	Selection of Time Parameters	Y	E	—	Y
Y	Year	00	99	—	19
N	Month	01	12	—	01
D	Date	01	31	—	01
H	Hour	00	23	—	00
E	Minute	00	59	—	00

Notes: If other parameter need to be changed, please contact after-sale or local distributor of us for setting.

Select SJ in the parameter by setting key, enter the setting of the current time, display Y, can select the parameter that needs to be adjusted by the upper and lower key, press the setting key to enter the setting of this parameter, adjust the parameter by the upper and lower key, and press the setting key to confirm.

Selection of SJ Time Parameters

Select this parameter to enter the current time settings and view.

8.1.2 Alarm code

Alarm code	Describe	Alarm code	Describe
AL	Low temperature alarm	E1	RT1 sensor error
AH	High temperature alarm	E2	RT2 sensor error
ALT	Low ambient temperature alarm	E3	RT3 sensor error
AHT	High ambient temperature alarm	E4	RT4 sensor error
Ado	Ajar door alarm	E5	RT5 sensor error
AUF	Power failure alarm	E6	RT6 sensor error
AHC	Condenser High Temperature Alarm	E7	RH sensor error
AdF	Battery alarm		



IX. Daily Maintenance

Warning: in order to avoid electric shock and physical injury, please cut off power supply of the equipment before repair or maintenance.

Ensure not inhale medicine or suspended particles surrounding this equipment, otherwise, it may possibly cause harm to your health.

9.1 Clean the Storage Cabinet

- Please clean the storage cabinet once a month. It can keep the new appearance of the storage cabinet after periodical cleaning.
- Wipe off dust from the enclosure and internal chamber and all accessories of the storage cabinet. If the storage cabinet is very dirt, please wipe off the dirt with soft fabric after immersing in PH-balanced detergent, and then wipe off the remained detergent with wet fabric, and then wipe with dry fabric. (Undiluted detergent may damage the plastic parts. .Please refer to the instructions of detergent for diluting it.)
- Do not directly pour water on enclosure of the equipment, otherwise, it may possible damage the electric insulation and cause fault.
- The compressor and other mechanical parts are under completely closed state and don't need lubricating.
- Remove the frost or ice from the internal wall once a month.

9.2 Internal Wall Defrosting

Frost may keep on the rack in the cabinet and may possibly cause gap between the cabinet body and door seal and drop the cooling effect, please remove frost after cutting off power supply, the followings are the method for defrosting through blanking the cabinet.

! **Note:** Please do not remove frost with toll of sharp edge such as knife or screwdriver.

- 1. Take out the objects from the cabinet and store in other storage cabinets or container with frozen liquid carbon dioxide.
- 2. Cut off power supply.
- 3. Open the small doors, keep the external door open to defrost for a moment.
- 4. Remove the water from the bottom of the cabinet with dry fabric.
- 5. Start the storage cabinet after cleaning the cabinet body.
- 6. Put the objects into the completely refrigerated cabinet.

X. Trouble shooting

Please check the followings before notifying the repair technician if there's fault:

The equipment can't start



- Check if power is correctly connected, if the main power switch is turned on?
- Check if the power voltage is too low?
- Check if too much objects are stored in the cabinet?

Bad cooling effect

- Check if the environment temperature is too high?
- Check if the external door is closed? (Frost between the cabinet body and door seal may possibly drop the sealing property of the door)
- Check if the temperature is set correctly?
- Check if the storage cabinet is far from direct sunlight?
- Check if the storage cabinet is near the heat source?
- If too much objects are stored in the cabinet within several hours? (Under this condition, the problem is temporary, please rise the setting temperature, stop and start the storage cabinet normally in a short moment to gradually drop the setting temperature.)

Noise

- Check if the storage cabinet is installed on the solid floor?
- Check if the storage cabinet enclosure contacts any foreign object?
- Check if the storage cabinet is working under low temperature state?
- If there are too many objects in the cabinet which may cause high temperature, the storage cabinet may make noises sometimes. And the noise will drop as the temperature drops.
- Check if the noise is from the compressor (the compressor noise of the low temperature equipment is higher than the compressor of home appliances)
- Knock noise. It may possibly cause by the acute cooling and contracting of internal parts, please drop the temperature gradually for avoiding sudden temperature drop in a short moment.

XI. Abandoned Equipment Treatment



Warning

If the equipment is kept in the open area for a long period, please ensure that children won't approach the equipment, and the cabinet door should not be closed completely. The abandoned equipment shall be handled by corresponding technician. Remove the cabinet



doors for avoiding accident such as suffocation.

XII. Technical Data

12.1 Main technical parameters

Model	Climate type	Temperature in Cabinet °C	Effective Capacity L	Rated Voltage /Frequency	Refrigerant	Dimension
YR05320	SN/N	2~8 -10~-25	368 R:189L F:179L	220V~/60Hz	R600a R290	720×830×1870

12.2 Electric Circuit Diagram

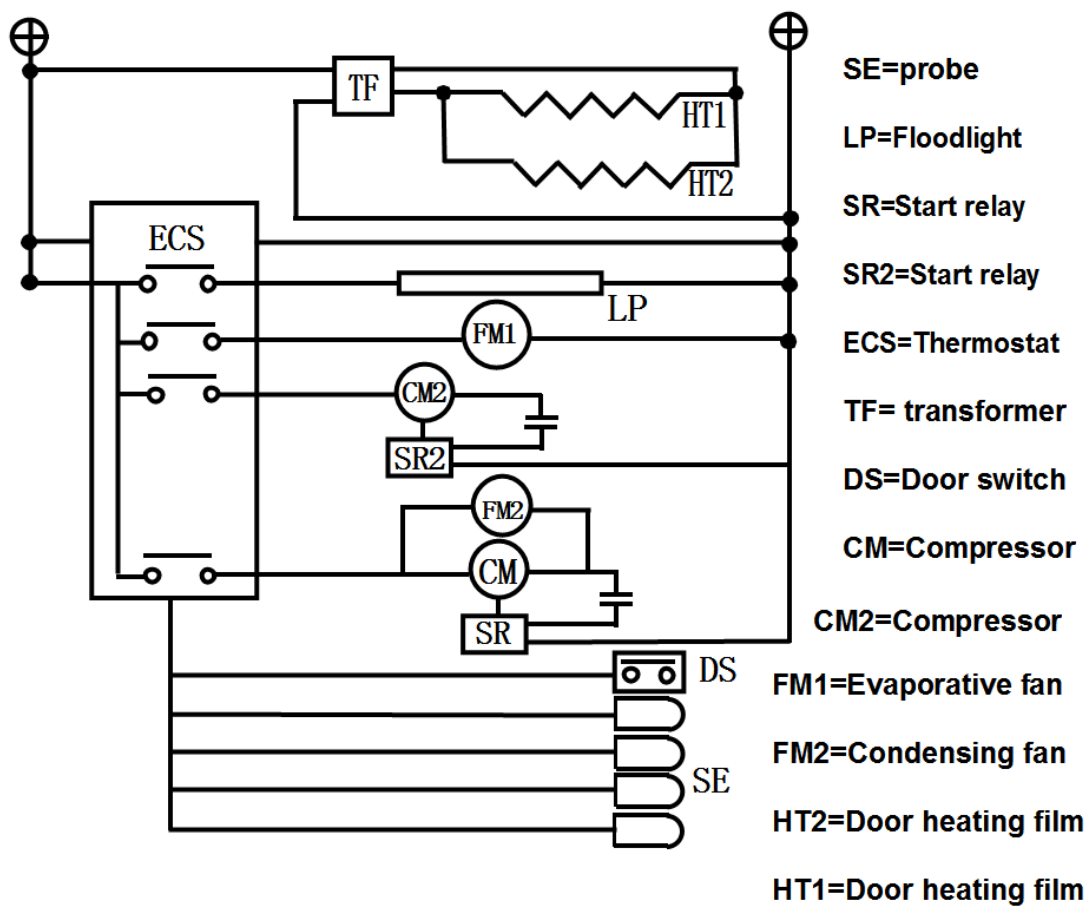



XIII. Packaging List

Model	User's Manual	Key	Position Limiting Sheet Metal	Shelf	Clip	Drawer	Cream shovel
YR05320	1	2	2	5	12	6	1

