

YR0098

BIOSAFETY CABINET

## Instruction Manual

Thank you very much for purchasing our Biosafety Cabinet YR0098.

Please read the “Operating Instructions” and “Warranty” before operating this unit to assure proper operation. After reading these documents, be sure to store them securely together with the “Warranty” at a hand place for future reference.



Warning: Before operating the unit, be sure to read carefully and fully understand important warnings in the operating instructions.



**YOUR ALTERNATIVE BRAND**





## Preface

Thank you very much for purchasing our class I biological safety cabinetry.

Please read the “Operating Instructions” and “Warranty” before operating this unit to assure proper operation. After reading these documents, be sure to store them securely together with the “Warranty” within touch for future reference.



Warning: Before operating the unit, be sure to read carefully and fully understand important warnings in the operating instructions.

### Disclaimer

Kalstein shall not be liable for any equipment failure or damage, or for any direct or indirect damage that may occur during the use of the equipment.

1. Malfunction or damage due to violation of the instructions, precautions, and intended use of this manual.
2. Malfunction or damage caused by repair or alteration of the other company.
3. Malfunction or damage caused by use instruments of other company at the same time .
4. Malfunction or damage caused by operating environment not corresponding to the specified operating environment (power conditions, installation environment, etc).
5. Malfunction or damage caused by natural disasters such as earthquakes and floods.
6. Malfunction or damage caused by the company unaware of the movement or transfer (transport) after installation.



## Content

1. Unpacking, Installation, Debugging .....	3
1.1 Unpacking .....	3
1.2 Accessories checking.....	5
1.3 Installation conditions and using environment.....	6
1.4 Installation .....	6
1.5 Checking after installation.....	6
2. User Instructions .....	7
2.1 Functions.....	7
2.1.1 Product Concept.....	7
2.1.2 Working theory/Air flow pattern and protected area .....	7
2.1.3 Protected objects.....	7
2.1.4 TECHNICAL PARAMETERS.....	8
2.2 Product structure .....	9
2.2.1 Structural composition of YR0096 & YR0097.....	9
2.2.2 Structure introduction .....	9
2.3 Instructions for Operation.....	12
2.3.1 Normal Operation Notice.....	12
2.3.2 Operation Process .....	13
2.4 Daily maintenance.....	13
2.4.1 Clean the working surface.....	13
2.4.2 Clean the external surface and front window.....	14
2.4.3 Overall maintenance period.....	14
2.4.4 Maintenance methods .....	14
2.4.5 Storage conditions .....	14
2.5 Replacement parts list.....	14
2.6 Wiring diagram.....	16
3. Trouble shooting and Labels.....	17
3.1 Common faults & solution.....	17
3.2 Replace the fuse.....	18
3.3 Replace LED lighting fixtures.....	19
3.4 Replace the UV lamp.....	19
3.5 Label Description .....	20
3.5.1 Fuse label .....	20
3.5.2 Ground label .....	20
4. Warranty.....	21



## 1. Unpacking, Installation, Debugging

Please firstly check if packing box is in good condition. If the packing box is damaged, please take photos.

### 1.1 Unpacking

Choose the proper unpacking method according to the actual situation. For wooden box:

- 1) Method 1 Use M8 Wrench to unpack



Picture 1

- 2) Method 1 Necessary tools for unpacking: Electric drill with hexagon dead M8



Picture 2

Rapid unpacking diagram (Picture 3). Disassemble the screws shown in the below Picture, then move the wooden pieces to right and left.

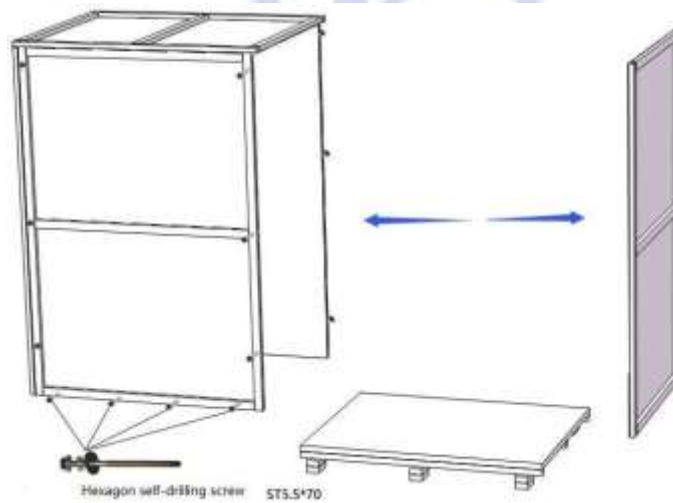

Picture 3

For carton box:

Using ordinary scissors to cut packing tape, take off the package cover, then move up the paper box body.

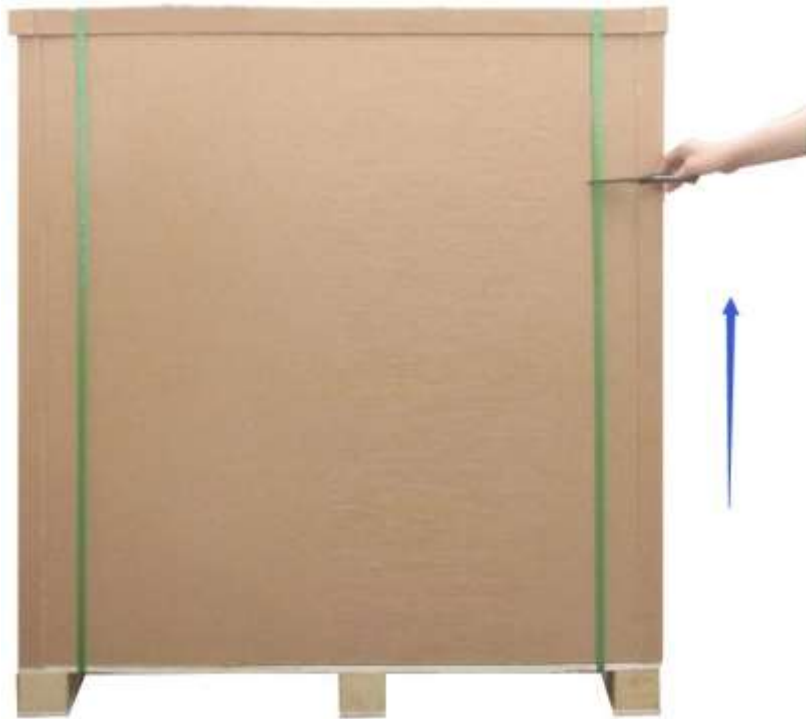

Picture 4

## 1.2 Accessories checking

Refer to the packing list and check the accessories.

YR0098 Packing List

Items	Quantity	Location
YR0098 Main Body	1 unit	Wooden Case
Power cord	1 pc	Packing bag
Fuse (5A)	1 pc	Document pouch
UV Lamp (T6 20W)	1 pc	Paper Packing
User manual	1 pc	Document pouch
Test report	1 pc	Document pouch
Quality certification card	1 pc	Document pouch
Warranty card	1 pc	Document pouch
Product acceptance certificate and installation report	1 pc	Document pouch
Training certificate	1 pc	Document pouch



### 1.3 Installation conditions and using environment

Biological safety cabinets should be placed in a position where there should be no opposing wall and far away from ventilation system and air conditioner vent, so as to avoid the airflow impact caused by ventilation system, air conditioner, door, window and even the personnel movement. Also, avoid blocking the local switch door entrance; avoid opposing and placing in the wall corner. There should be at least 300mm of the side of the safety cabinet for checking.

Working environment:

- (1) Only is suitable for indoor;
- (2) Ambient temperature: 15°C~35°C;
- (3) Relative Humidity: ≤75%;
- (4) Atmospheric pressure range: 70 KPa~106 KPa;
- (5) Electrical parameters: Consistent with the rated voltage of the biological safety cabinet (See 2.1.4 technical parameter performance index);
- (6) Power supply need to be grounded; (Judging method: testing the fire wire and the zero line of the power supply with multimeter, the fire wire to ground voltage should be grid voltage and the zero line to ground voltage should be 0, otherwise the power supply ground is bad);

### 1.4 Installation

- a、 Remove all the package materials;
- b、 Inspect the surface of main body to make sure whether there is scratch, deformation or uncorrelated things;
- c、 Check the accessories and documents according to the packing list. Move the device to the final place for installation.

### 1.5 Checking after installation

First, make sure the Voltage and frequency to be same as logo showing, and then check the follows items with power on:

Items	Normal Condition
Fan Runing	Normally
LED Lamp	Light on when press the corresponding button
UV Lamp	Light on when press the corresponding button
Display screen buttons	All buttons can be used



If you have any questions, please contact the Engineer for the process of debugging, debugging methods in the after-sales service manual.



## 2. User Instructions

### 2.1 Functions

#### 2.1.1 Product Concept

The developments of medical technology enable people to improve the understanding of microbial protection and pay more attention to laboratory safety. Thus there are more requirements for laboratory equipment's safety while it is more complete and standard. Clinical laboratories of medical institutions and scientific research laboratory will produce aerosol particles inevitably in the experimental operation, such as the mixing, stirring, grinding, crushing, centrifugal of sample pretreatment, and carrier of inoculating loop burning, dirt high pressure heating exhaust can be generated aerosol. The Class I biological safety cabinet can adequately protect the harm caused by aerosol pollution, and effectively protect the personnel and environment.

It is negative pressure air inlet in front window of Class I biological safety cabinet which can protect the operators and the exhaust air goes through HEPA filter which can protect the environment. The Class I Biological safety cabinet can be placed on anywhere with it's simple and portable structure.

#### 2.1.2 Working theory/Air flow pattern and protected area

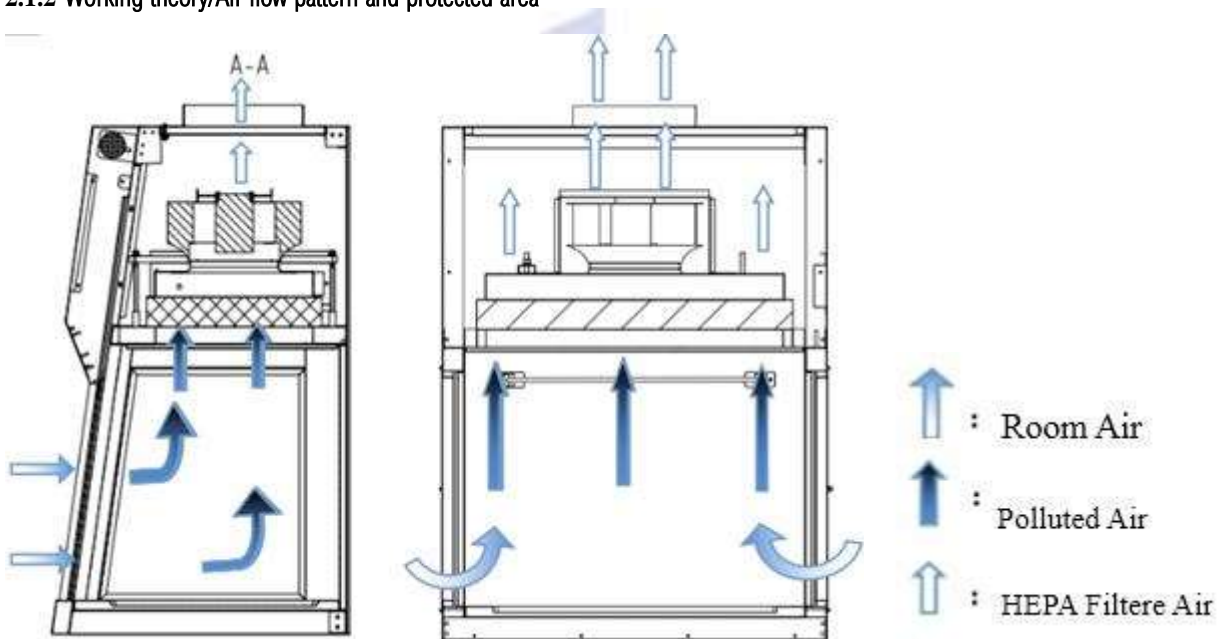

Picture 5

#### 2.1.3 Protected objects

The Class I biological safety cabinet are designed to protect the operator, the laboratory environment and work materials from exposure to infectious aerosols and splashes that may be generated when manipulating materials containing infectious agents, such as primary cultures, stocks and diagnostic specimens.



### 2.1.4 TECHNICAL PARAMETERS

Model	YR0098			
Parameters				
Power Supply AC	220V±10%	<input type="checkbox"/>	110V±10%	<input type="checkbox"/>
Frequency	50 Hz	<input type="checkbox"/>	60Hz	<input type="checkbox"/>
External Size(W*D*H)	900*713*1250 mm			
Working Zone Size(W*D*H)	800*635*600 mm			
Consumption	≤400 W			
Average airflow	> 0.3m/s			
LED fluorescent lamp Consumption	T5 8W			
UV Lamp Consumption	20W			
HEAP Filter	99.985% (Diameter:0.3μm)			
Noise	≤60 dB(A)			

Notes: (1) Our company has right for changing the products, if we need to change and re-design, please forgives us for not notifying you.

#### 1) Illumination

The average illumination is no less than 300lux. 2)

#### Electrical properties

The voltage increases to 1390V(AC) in 5s and keep for another 5s without breakdown. Grounding resistance ≤0.1Ω .

#### 3) Vibration amplitude

The net vibration amplitude between frequency 10Hz and 10KHz is no more than 5μm (rms).



## 2.2 Product structure

### 2.2.1 Structural composition

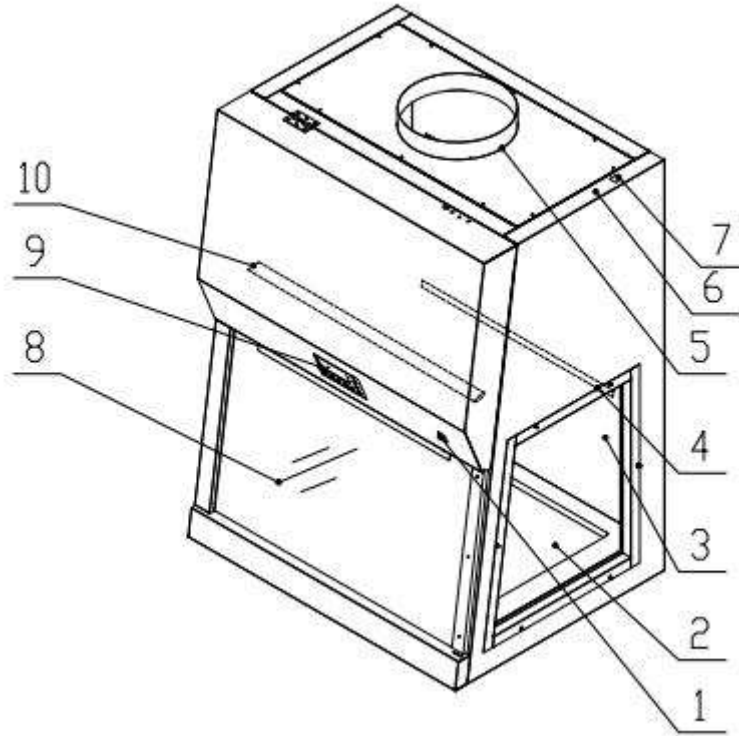

Picture 6

- |                     |                      |                 |                 |
|---------------------|----------------------|-----------------|-----------------|
| 1. Ship type switch | 2. Countertop        | 3. Side window  | 4. UV lamp      |
| 5. Chimney fan      | 6. Ground terminal   | 7. Power socket | 8. Front screen |
| 9. Control panel    | 10. Fluorescent Lamp |                 |                 |

### 2.2.2 Structure introduction

#### 1) Front glass door:

Front glass door is made of toughened glass, which have little damage to human when cracking. Front window was controlled by motor, it could up and down by adjusting direction switch.

#### 2) Air Filtration System

Air Filtration System is the most important system of this machine. It consists of blower, purify air filter and air flue. Aerosol produced during experiment operation enter Biosafety cabinet Class I with the air outside, then Filtration System will filter the dust particle or infectant and exhaust the purified air to external environment. Air Filtration System use the HEPA filter, which make sure the cleanliness of air outlet.

**Note:** Though Biological biosafety cabinet could protect operator and environment from harm, it couldn't make sure the samples used in experiment won't be polluted by the air in lab. It couldn't foreclose the possibility of cross-infection.



3) UV light:

UV lamp was used to sterilize. They located in interior of work area, and fixed at the top of operating area, where could make sure all space of work surface sufficiently exposure to the UV light.

4) Fluorescent light:

Fluorescent light can make sure illumination inside work area. LED lamp located in the top of operating area, keeping the illumination inside work area no less than 500Lux. Easy to change.

5) Operation Panel:

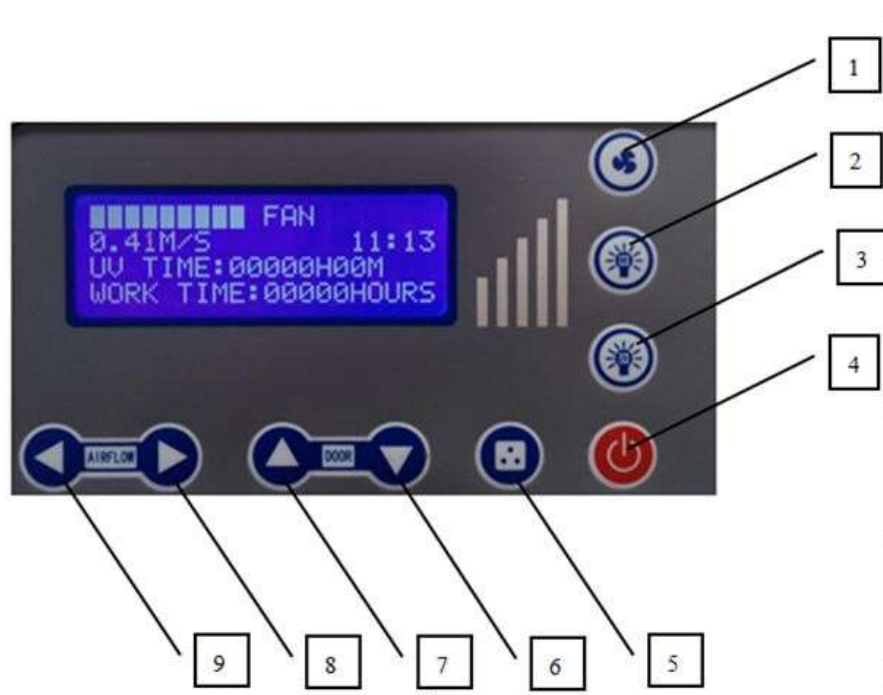

Picture 7

- |                    |                      |                      |
|--------------------|----------------------|----------------------|
| 1. Blower          | 2. Fluorescent Lamp  | 3. UV Lamp           |
| 4. Power           | 5. Socket            | 6. Glass window down |
| 7. Glass window up | 8. Air-flow decrease | 9. Air-flow increase |













a. Screen Display

The air-flow working status of the equipment can be seen on the screen.

b. Soft touch button

Operation of equipment could be executed by touch-buttons.



- (1).  Power button: control other function buttons. For each time pressing, buzzer will be ringing, and the status of LCD display will be changed at the same time (Turning lighter or darker). The system would be switched between standby mode and work mode.
- (2).  Blower button: control the working status of blower. For each time pressing, the blower's work status and indicator light displayed on LCD will be changed. Blower memory function make sure that it will maintain the work status same with last time power off. Blower could not be start when glass door closed.
- (3).  To Control Flourescent Lamp: For each time pressing, LED lamp's status and indicator light displayed on LCD will be changed (Turning on or off).
- (4).  To Control UV Lamp: For each time pressing, UV lamp's status and indicator light displayed on LCD will be changed (Turning on or off). UV lamp, blower, flourescent lamp and front window are interlocking. UV lamp will be auto switched off when flourescent lamp, blower and front window are opened.
- (5).  Glass window down button: For each time pressing, buzzer will be ringing. Glass window will keep going down when this button was pressed. Glass window stop going down when button was released.
- (6).  Glass window up button: For each time pressing, buzzer will be ringing. Glass window will keep going up when this button was pressed. Glass window stop going up when button was released.
- (7).  Air-flow decrease button: When blower is working, if the quantity of  are more than one, operator could press this button to decrease the air-flow. For each time press, the air-flow will be decreased by one gear with buzzer ringing for one time, until the quantity of  is one.
- (8).  Air-flow increase button: When blower is working, if the quantity of  are less than nine, operator could press this button to increase the air-flow. For each time press, the air-flow will be increased by one gear with buzzer ringing for one time, until “” was displayed.
- (9). LCD display: Power on. Display content from top to bottom:  FAN (show air-flow when blower is working). Current status of air-flow, time is displayed on right side (Time adjusting will be introduced next). UV TIME (Work time of UV lamp. For time resetting, please check 3.4). WORK TIME(Work time of the filter).
- (10). Clock adjustment: In standby mode, continue to press the Flourescent Lamp button and one alarm sound means clock set condition is ready, then minutes position start to twinkle, the



Decrease button and Increase button could adjust minutes. Then press Blower button, hour position started to twinkle, the Decrease button and Increase button could adjust hours. When finished, continue to press the Fluorescent Lamp button and one alarm sound means time reserved.

6). Ship type switch.

Main switch of equipment, have Power On and Power Off two status. When power on, only when the Ship type switch ON, the control panel could start and work.

7). Structure.

- a. Cabinet body is built of 1.2mm cold-rolled steel with anti-powder coating. Strong and steady.
- b. Work area is fully made of 304 stainless steel which looks beautiful and with corrosion resistance performance.
- c. Soft touch type control panel, easy to handle and beautiful appearance.

## 2.3 Instructions for Operation

### 2.3.1 Normal Operation Notice

- 1) Before AC power connecting, make sure input voltage is correct and stable. The rated load of main power socket should be higher than cabinet consumption. YR0098 adopt grounded plug, which only could be used with grounded socket. This is a kind of safety device. If the plug cannot be inserted into the socket, please ask electrician to install grounded socket.
- 2) The weight of items placed in the cabinet should be no more than 23Kg/25×25cm<sup>2</sup>
- 3) Samples placed in parallel: Samples should be placed in the cabinet parallelly to avoid cross-contamination between samples.
- 4) In order to avoid samples being sucked into the negative passage or the blower, do not place soft and slight samples (for example: soft tissue) on the surface during experiment.
- 5) Avoid vibration: avoid using vibration equipment inside the cabinet. Vibration would cause particulate matter shake off from filter membrane, causing lower cleanliness of operating area.
- 6) No flame: No flame is allowed inside the cabinet. Using of fire will lead to airflow disorder, and filter damage. If sterilization is required during the experiment, infrared sterilizer is highly recommended.
- 7) HEPA filter life: With the usage time increasing, dust and bacteria accumulate inside HEPA filter. Filter Resistance is getting bigger, when it reaches the maximum point, there will be audible alarm. Please replace new HEPA filter, otherwise it will affect the safety performance of the equipment. Interior components shouldn't be abandoned at random when the equipment is maintained or scraped. There are biological hazards of components, please processed based on local laws and regulations.
- 8) Blower and underside steel plate are static pressure, back door is dam-board of negative pressure air passage, which is sealed strictly in factory. The operator is not allowed to remove or loose screws of those parts. If necessary, please contact service personal.
- 9) The maximum storage period is one year. If the period is more than one year, performance test should be done by technical staff. Then it could be put into operation if qualified.



Serious declaration: we will take no responsibility for risks caused by improper operation and man-made damages!



### 2.3.2 Operation Process

- a. Connect the same AC power supply as required of equipment;
- b. Open the ship type switch, electrify the equipment. Pressing the relevant function button (Introduction and operation of function buttons, please check 2.2.2 ) to check if the function buttons are accordance with operating result and check the blower start and air-flow, fluorescent lamp and UV lamp based on the above Technical Parameters.
- c. Before using, please make the front window down to bottom and sterilize the cabinet for more than 30 minutes by UV lamp.



(1) For safety of eyes and skin, people should leave room during the UV sterilization, avoiding the damage from exposing to UV light.

(2) UV lamp intensity should be tested regularly based on manufacture's specification.

Working time of UV lamp reaches to 600 hours regularly.

- d. Please move the front window at a appropriate height, turn on the fan, experiment operation could be start normally after fan working 5 minutes.
- a. UV lamp, flourescent lamp and blower are interlocking: STERILIZATION button is invalid when flourescent lamp and blower are starting. Other buttons are invalid when UV lamp opening.



For operating safety, please put testing materials inside the cabinet in advance.

## 2.4. Daily maintenance

Preparations before maintenance: Remove the things which placed in the cabinet

You need: Soap, hot water or warm water, a soft cotton cloth, dry cloth or towel, medical alcohol or other disinfectants, etc.

### 2.4.1 Clean the working surface

Wipe the entire surface with a soft cotton cloth or towel soaked with concentrated liquid soap, then wipe up the soap with another cotton cloth or towel soaked with clean hot or warm water, and then wipe the surface with a dry cotton cloth or towel rapidly.

For the contaminated or dirty work surface or sump., use 70% medical alcohol or other disinfectant to wipe.



Disinfectants used for wiping should not damage 304 stainless steel.



#### 2.4.2 Clean the external surface and front window.

Use soft cotton cloth or towel to wipe the surface with non-abrasive household cleanser.

#### 2.4.3 Overall maintenance period

We suggest comprehensive maintenance period is one year or 1000 working hours.

#### 2.4.4 Maintenance methods

- 1) Weekly or daily maintenance
  - a. Disinfect and clean operating area (refer to 2.4.1) ;
  - b. Clean the external surface and front window around the operating area (refer to 2.4.2) ;
  - c. Check the various functions of equipment;
  - d. Record this maintenance result;
- 2) Monthly maintenance
  - a. Clean the external surface and front window. (refer to 2.4.2) ;
  - b. Wipe the working table, inner wall surface of operating area (excluding the wind distributing grid of operating area) and the inner surface of glass door with 70 % medical alcohol or household bleach diluted 1:100 (i.e. 0.05% sodium hypochlorite). Then wipe again with sterile water in order to eliminate the rest chlorine.
  - c. Check the various functions of equipment;
  - d. Record this maintenance result;
- 3) Annual maintenance
  - a. Check the two conveyor belts of front window drive unit, and ensure that their tightness is coincident.
  - b. Check the UV lamp and fluorescent lamps.
  - c. Apply for testing the overall performance of cabinet on an annual basis to ensure the performance safety.  
User is responsible for testing costs.
  - d. Record this maintenance result.



When doing maintenance, please pay attention to cut off the power, so as to avoid electric shock!

#### 2.4.5 Storage conditions

Safety cabinet should be stored in a relative humidity no more than 75%, the temperature is below 40°C, in the warehouse with good ventilation performance, no acid, no alkali and no other corrosive gases, storage period shall not exceed one year, safety cabinet for more than a year needs to unpacked and checked. Only the tested and qualified safety cabinet can be sold.

## 2.5 Replacement parts list

YR0098 replacement parts list

No.	Name	Specification
CX-01	Fuse	5A
CX-02	Lamp holder T8	LG13-01A





CX-03	UV Lamp	T6 20W
CX-04	LED Lamp	T5 8W
CX-05	UV lamp ballast	1*TL8-18W
CX-06	HEPA	740*420*69
CX-07	Fan	FH320A
CX-08	Control Panel	Clean Bench (LCD) Control Panel
CX-09	Front Window	818*520*5
CX-10	Side Window	(409.6+485.5) *540*5
CX-11	Tubular Motor	TMN45-10/17
CX-12	Travel Switch	'RV-156-1C25







### 3. Trouble shooting and Labels

#### 3.1 Common faults & solution

Please confirm whether the power is connected or not, whether the power cord is obvious damaged or not, whether the fuse is good or not, and whether the power locks are in the open state or not before the fault diagnosis.

Faults	Check parts	Measures
LED lamp doesn't work	LED lamp holder plug	Check if the holder plug connect well with holder
	LED lamp holder	Change it
	Control Panel	Change it
UV lamp doesn't work	Lamp Holder	Tube and lamp holder is connected securely.
	UV Lamp	Change it
	Ballast	Change it
	Circuit	Check circuit
	Chain	Check the front window, fluorescent lamp and the blower is open or not.
	Travel Switch	Check if it is off
Button doesn't work	Control panel	Make sure the power connects well and the fuse is well
		Check if the button is broken
		Make sure the connecting wire is connected well
		Change control panel



Blower doesn't work	Travel Switch	Check if it is closed
	Blower	If blower is broken, change it
	Circuit	Check circuit
	Control panel	Change it
No electricity in equipment	Power supply	Check power supply connects well
	Power wire	Check whether power wire has obvious damage
	Power key	Check if power key is open, is broken or not.
	Fuse	Check if the fuse is good
	Transformer	Check whether the transformer works normally
	Control panel	Change it
Display doesn't work	Connect wiring	Check whether connecting wire is connected well
	Display	Check whether display is in good condition
	Control panel	Change wiring board
Front window doesn't work	Transmission part	Check transmission connection and lead rail
	Motor of front window	Check front window motor
	Circuit	Check circuit
	Control panel	Change it



## NOTES

- (1) The above electrical parts must be operated by a qualified electrician in safety conditions (cutting off power supply). The other parts are not allowed to remove; otherwise the user should take responsibility by them;
- (2) When other failures occur, and the operator can't solve, please notify our maintenance department immediately. For your safety, please do not maintain equipment by yourself;
- (3) The maintenance of this equipment is undertaken by trained and recognized technicians;
- (4) If you need to order parts, contact the agent or our technical service department, and please indicate the model and serial number of the cabinet purchased.

### 3.2 Replace the fuse

The fuses are F2A  $\phi 5 \times 20$  mm. When replace them, turn off the power and disconnect plug, use a Phillips screwdriver counterclockwise pressing screwed fuse holder, remove the fuse out and replace a new fuse, and then clockwise pressing screwed fuse holder (refer to Picture 9).



Picture 9

### 3.3 Replace LED lighting fixtures

When replacing lights, make sure that the power is off. Open the front window, then remove the unplug the right side LED stand plug, remove the LED lamp. After replacing a new LED lamp, inserted into the LED stand plug. The replacement measurement pls refer to picture 10

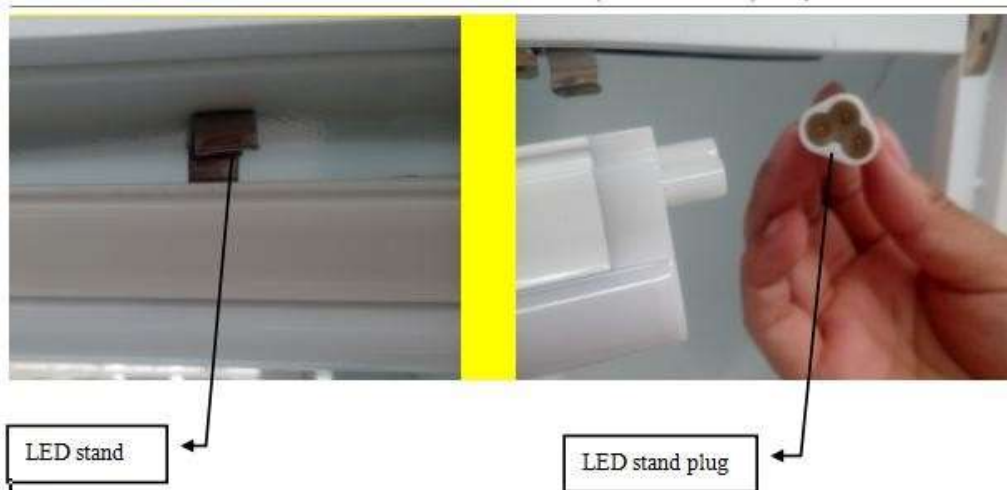

Picture 10

### 3.4 Replace the UV lamp

UV lamp should be replaced regularly according to the frequency of use, when using UV lamps reach to the time of 600 hours, we recommend to replace the lamp. In order to achieve good disinfection effect, it is recommended that you regularly test the UV intensity, you can use the UV intensity test card to confirm whether you need to replace the UV lamp. When replacing, first make sure the power is off, and then screw the bulb 90 ° and take it off, then take the correspondence type of lamp, and put it to the lamp holder and screw 90 ° in reverse direction. (refer to Picture 11).



Picture 11

### 3.5 Label Description

#### 3.5.1 Fuse label

When voltage is  $110V \pm 10\%$ , the fuse label is as below:

F2AL

When voltage is  $220V \pm 10\%$ , the fuse label is as below:

F2AL 250V

#### 3.5.2 Ground label



Picture 12



## 4. Warranty

- 1) Warranty is 12 months from EX-factory date (excluding consumable accessories, UV and Fluorescent lamp, fuse).
- 2) We will take no responsibility for risks caused by improper operation and man-made damages.
- 3) After the expiration of warranty, our company is also responsible for repairs, but the corresponding maintenance cost should be charged.
- 4) Life time of biological safety cabinet is 8 years from production date on the label.
- 5) We can provide equipment drawings and necessary technical data for maintenance companies or personnel trained by our company.

**Warranty declaration: One-year Warranty, Life-long Maintenance**



All rights reserved © KALSTEIN France S. A. S.,  
Optimum Business Center 450 Rue Baden Powell,  
• 34000 Montpellier, France.  
Tlf: +33 467158849 / +33 680760710/ +33 663810023  
<https://kalstein.eu>  
**KALSTEIN FRANCE, S. A. S**

