



Freezer Dryer

Model YR05983

## Instruction Manual

Thank you very much for purchasing our Kalstein's Freezer Dryer Model YR05983

Please read the "Operating Instructions" and "Warranty" before operating this unit to assure proper operation. After reading these documents, be sure to store them securely together with the "Warranty" at a hand place for future reference.



**Warning:** Before operating the unit, be sure to read carefully and fully understand important warnings in the operating instructions.



OUR SERVICES

## Benefits and Support

In Kalstein France, we take care of the full satisfaction of our customers, that is why we provide value-added services of the highest level based on our experience.



### Online Inductions and Trainings

In any part of the world, receive your induction or training from our specialized team of engineers



### Quick Response

Our work team is always available to response all your consults or questions, in order to support you in any situation.



### #Letsgivemore

Thanks to your purchase, a donation will be made to a non-profit foundation that fights against breast cancer and helps most vulnerable communities.



### Technical Support

Enjoy of personalized advice for the correct preventive and corrective maintenance of your equipment, thanks to Kalstein's manuals and articles, special catalogues and video tutorials.



### Delivery Logistics

We take care of all the necessary logistics for the dispatch of your goods, whether is by sea, land or air.



### Kalstein Worldwide

With more than 25 years growing with our customers, Kalstein's multiformat and modern content, is now present in more than 10 countries and increasing.





## CONTENT

### General .1

1.1.	Introduce.....	1
1.2.	Application .....	1
1.3.	Specification for YR freeze dryer .....	1
1.4.	Safety .....	2
1.4.1.	Attention: Remove the power plug .....	1
1.4.2.	Attention: Chemical solvent .....	1
1.4.3.	Note: Clean and maintenance freeze dryer.....	2
1.4.4.	Warning: Do not touch the condenser chamber's internal surface .....	2
1.4.5.	Note: delivery or handling requirements .....	2
1.4.6.	Below operations are prohibited.....	2
<b>2</b>	<b>Technical characteristics .....</b>	<b>3</b>
2.1.	Main features .....	3
2.2.	Technical performance.....	3
<b>3</b>	<b>Working condition .....</b>	<b>3</b>
<b>4</b>	<b>Normal information for vacuum freeze drying.....</b>	<b>3</b>
4.1.	Basic knowledge .....	3
4.2.	vacuum freeze-drying process .....	4
4.3.	Pre freezing.....	4
4.4.	Main drying .....	4
4.5.	Drying endpoint and ventilation.....	6
4.6.	Defrosting .....	7
<b>5</b>	<b>Installation and operation .....</b>	<b>7</b>
5.1.	Components .....	7
5.2.	Attention when installation and testing.....	9
5.2.1	Power source .....	9
5.2.2	Fuse .....	9
5.2.3	Condensation and defrog .....	9
5.2.4	Vacuum exhaust devic .....	9
5.2.5	Start to running.....	9
5.3.	Installation step.....	9
5.4.	General operation process of freeze drying.....	10
<b>6</b>	<b>Control system operation .....</b>	<b>10</b>
<b>7</b>	<b>Attentions.....</b>	<b>13</b>
	<b>Common trouble and shooting .....</b>	<b>12</b>
<b>9</b>	<b>Warranty and maintenance .....</b>	<b>12</b>

## 1. General

### 1.1. Introduction

Vacuum freeze drying is the removal of water or other solvents from the frozen samples. During the whole drying process, the sample is in liquid state and the temperature is generally lower than -10. The purpose of vacuum freeze drying is to restore the original characteristics of the sample after rehydration.

Because the drying process is carried out at low temperature, it can be used for some materials such as proteins, which are easy to be denatured at high temperature, and can ensure that the properties of other compounds will not change.

Most of the biological products, such as tissues, tissue extracts, bacteria, vaccines and serum, were changed into dry samples by vacuum freeze-drying. Vacuum freeze drying is the gentlest process to preserve the biochemical properties of sensitive tissue or other tissues. It is also the best method for drying inorganic materials, such as nano particles, because the surface area of particles is almost unchanged.

### 1.2. Application

YR05983 vacuum freeze dryer is a kind of freeze-drying machine widely used in high performance laboratory. Freeze dry glass flask and serum bottle of solid and liquid samples. A variety of containers can be carried out on the same freeze dryer:

The pre freeze shelf surface temperature control

The samples of freeze-dried can be carried out in the user defined temperature

Dry in the limit temperature of freezing - user defined samples, high vacuum drying, and can remove capillary bound water molecules.

YR series machine is applicable to the bacteria, virus, plasma, serum extract, antibody, vaccine and drug products: such as chloramphenicol, streptomycin, vitamins, enzymes and biological test of the plant extracts.

### 1.3. Specification for YR Series freeze dryer.

product name	Power (w)	Host size (L*W*H) mm	Product Description	
YR05983 Vacuum Freeze Dryer	1100	600*700*780	Cold trap temperature: $\leq -35^{\circ}\text{C}$ ; Drying temperature: $-25\sim +60^{\circ}\text{C}$ No load: $<15\text{Pa}$ Water catching capacity: 1-2KG Separator: 3 layers with heated separator	Partition size: 150mm*280mm; Partition spacing: 45mm; Material tray size: 145mm*275mm, 3 pieces;

### 1.4. Safety

#### 1.4.1. Attention: Remove the power plug



The power should be shut down, and the power plug should be removed when maintenance or open the frame cover.

#### 1.4.2. Attention: Chemical solvent



The samples with high acid or solvent content cannot be dried in the absence of special protection (if necessary, please contact the service department), otherwise the freeze dryer may be corroded. When drying

containing aside should pay more attention to it, because with copper or other nonferrous metal reaction will explode.

#### 1.4.3. Note: Clean and maintenance freeze dryer



For infectious, toxic, pathogenic and radioactive substances, it should be to do the appropriate safety precautions.

#### 1.4.4. Warning: Do not touch the condenser chamber's internal surface



In the process of freezing, the temperature of condenser chamber is very low. When putting sample inside, the fingers do not touch chamber. Otherwise, the fingers may freeze to the surface.

#### 1.4.5. Note: delivery or handling requirements



Don't hold the control panel when delivery and put down the machine. Be careful with your hand to avoid crushing.

#### 1.4.6. Below operations are prohibited

- (1) The freeze dryer is not properly installed
- (2) It's not allowed or authorized
- (3) The tray is not fixed
- (4) It is not possible to freeze dry corrosive substances without special safety measures. Even in the case of protection, it is necessary to ensure that no corrosion to reduce the mechanical strength of the trap, door panels, and other accessories.
- (5) Not allowed to add attachments. Do not use container with poor quality. Because it is very dangerous with burst risk.
- (6) Do not use freeze dryers in areas where there is a risk of explosion.
- (7) Do not move or compact the freeze dryer, do not lean on or rest on it when working.
- (8) Do not place potentially dangerous objects, such as liquid bottles, in the vicinity of a freeze dryer.
- (9) Do not dry the samples which will react when freeze dry.
- (10) Do not freeze dry explosive or flammable samples.

## 2. Technical characteristics

### 2.1. Main features

- (1) The machine adopts Tecumseh or Secop, rapid cooling
- (2) LCD control system, easy to operation, and powerful function
- (3) The dry room door is made of colorless transparent organic glass, and the whole process of freeze drying can be observed.
- (4) The vacuum pump is connected by international standard KF quick connector.
- (5) Stable performance, easy operation and low noise.



## 2.2. Technical performance

- (1) Condenser chamber temperature:  $\leq -35^{\circ}\text{C}$  (without load)
- (2) Vacuum: under 15Pa (without load)。

## 3. Working condition

- 1、working ambient temperature:  $10^{\circ}\text{C}\sim 30^{\circ}\text{C}$   
relative humidity:  $\leq 70\%$   
supply voltage: single phase 220V-230v  
Horizontally, no conductive dust, explosive, corrosive gas and electromagnetic interference.
- 2、Delivery and storage condition: ambient temperature:  $-35^{\circ}\text{C}\sim 50^{\circ}\text{C}$   
relative humidity:  $\leq 93\%$   
Storage environment should be well ventilated, non-corrosive gas.
- 3、Security class I type B

## 4. Normal information for vacuum freeze drying

### 4.1. Basic knowledge

Vacuum freeze-drying is one of the gentlest ways to dry. It is based on the sublimation principle, that is, the solid phase directly into the gas phase of this physical phenomenon. The freeze-dried material is placed in a vacuum drying chamber for drying, and the water vapor produced by the cold trap is condensed to form ice, so as to achieve the purpose of eliminating water vapor. Vacuum pump is used to discharge the air in the drying room, not including water vapor.

The baffle plate is provided with a heating device, and the heat is transferred to the material through the conduction function to provide the energy needed for sublimation. When the free water in the material is sublimated, the internal bound water can also be removed from the material at a very low vacuum. This drying process is considered to be the last stage of drying, analytical drying.

### Sublimation

The principle of sublimation can be explained briefly with water map. When the pressure is higher than 611Pa, the water will go through three phases of solid, liquid and gas. When the air pressure is equal to 611Pa, the dissolution curve, the vapor pressure curve and the sublimation curve three lines are at one point, that is, the three-phase point. When the pressure is lower than 611Pa and reached the sublimation curve, the ice can be directly into a solid-state gas.

Note: The three-phase point of water is 0.01 degrees C and 611 Pa.

### Vapour pressure curve for ice and water

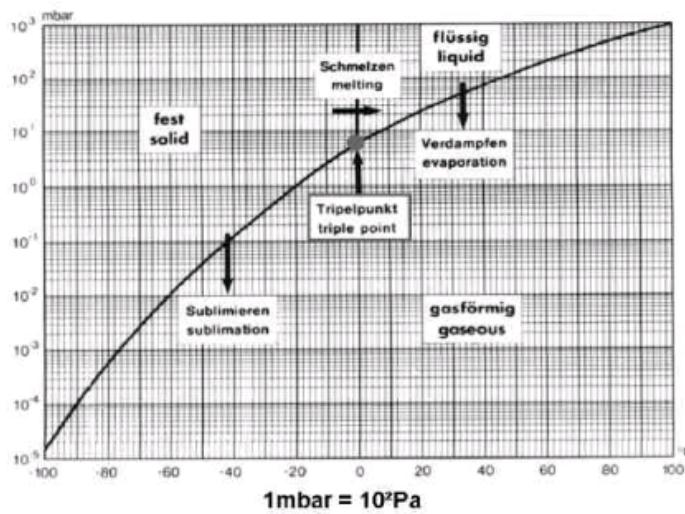

1mbar=10<sup>2</sup>Pa=1hPa

°C	Δ mbar	°C	Δ mbar	°C	Δ mbar	°C	Δ mbar
0	6.110	-20	1.030	-40	0.120	-60	0.011
-1	5.620	-21	0.940	-41	0.110	-61	0.009
-2	5.170	-22	0.850	-42	0.100	-62	0.008
-3	4.760	-23	0.770	-43	0.090	-63	0.007
-4	4.370	-24	0.700	-44	0.080	-64	0.006
-5	4.020	-25	0.630	-45	0.070	-65	0.0054
-6	3.690	-26	0.570	-46	0.060	-66	0.0047
-7	3.380	-27	0.520	-47	0.055	-67	0.0041
-8	3.010	-28	0.470	-48	0.050	-68	0.0035
-9	2.840	-29	0.420	-49	0.045	-69	0.0030
-10	2.560	-30	0.370	-50	0.040	-70	0.0026
-11	2.380	-31	0.340	-51	0.035	-71	0.0023
-11	2.170	-32	0.310	-52	0.030	-72	0.0019
-13	1.980	-33	0.280	-53	0.025	-73	0.0017
-14	1.810	-34	0.250	-54	0.024	-74	0.0014
-15	1.650	-35	0.220	-55	0.021	-75	0.0012
-16	1.510	-36	0.200	-56	0.018	-76	0.0010
-17	1.370	-37	0.180	-57	0.016	-77	
-18	1.250	-38	0.160	-58	0.014	-78	
-19	1.140	-39	0.140	-59	0.012	-79	

#### 4.2. vacuum freeze-drying process

Freezing: Under normal atmospheric pressure, reduce temperature to freezing to ice structure

Drying: Under certain vacuum, such as 1pa, and keep the water in solid phase.

Energy input: heating, keeping some matter in solid phase. The matter's temperature is controlled by certain vacuum.

#### 4.3. Pre freezing

The sample could be pre freezing in freezing dryer. Its thickness should no more than 1~2cm. Otherwise it should extend Freeze drying time.

#### 4.4. Main drying

Open the vacuum pump, create a vacuum environment, causing sublimation.

**Warning:**

- The substance of the acid or any other substance containing corrosive volatile solvents should not be dried with this machine.
- Pay special attention to asides cannot be used, because it combines with copper or other nonferrous

metals will explode.

- As soon as the water begins to sublime, it absorbs heat and causes the temperature to drop.
- The pressure in the drying chamber increases with the sublimation and must be reduced by the condenser.

**The duration of the main drying process is mainly determined by:**

- (1) Sample's thickness
- (2) Energy to sample when drying process
- (3) The chamber's pressure when drying process

Increasing chamber's pressure, could increase the rate of sublimation and shorten the drying period.

**The residual moisture in the dry matter is mainly determined by:**

- (1) The matter's temperature at final drying stage
- (2) The vacuum at final drying stage
- (3) When the matter's temperature is almost equal the tray's, the main drying stage is finished.

When the adsorbed water of the substance is also beginning to be discharged, the final stage of drying begins.

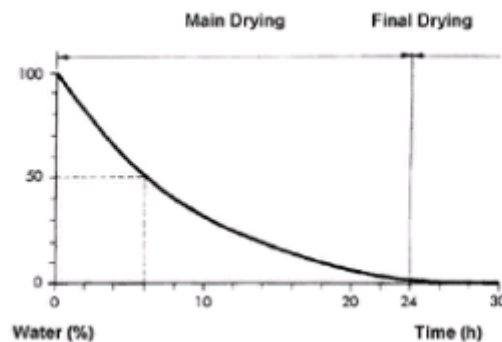

This figure shows the material drying process with about 10% solid phase material. After the main drying stage of the first 1/4 time, 50% of the water is condensed. In the next 1/4 time, 50% of the remaining water is also condensed.

In the process of freeze drying, the area where the material is sublimated gradually shrinks from the surface to the interior, so that the water vapor generated by sublimation needs to pass through the dry material layer to reach the outside of the material. Therefore, in the drying process, the sublimation resistance increases. The drying curve is mainly determined by the latent heat of sublimation and the velocity of water vapor transmission. In order to increase the thermal conductivity of the dry matter and to minimize the volume of water vapor, the drying conditions should be as close as possible to the freezing point.

Drying time depends largely on the degree of vacuum drying. Along the vapor pressure curve on the ice, the closer the vacuum degree is to the freezing point, the shorter the drying time.

**Interesting association:**

- 1.0g ice equal to
  - ✧ 1m<sup>3</sup> water vapor under 100Pa pressure
  - ✧ 10m<sup>3</sup> water vapor under 10Pa pressure
  - ✧ 100m<sup>3</sup> water vapor under 1Pa pressure

**Energy supply when drying process**

The energy needed by the dry material is mainly provided by the heating plate at the bottom of the tray. The heat transfer process is shown in the following figure.



### Effects of freeze drying of a product in a dish

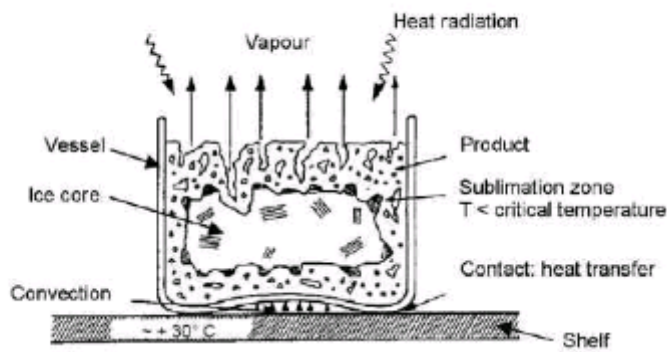

Heat transfer is achieved by direct contact between the bottom of the vessel and the material, as well as convection heat transfer between the vessel and the material.

At the beginning of sublimation, the heat transfer between the vessel wall and the frozen material is very effective. However, shortly after the formation of a layer of ice free, porous, dry area. The corresponding temperature step is formed between the vessel wall and the material. Have dry region of the thermal conductivity decrease led to the increase of the ice nucleation temperature, if the ice nucleation temperature rises to above freezing point temperature, the material began to thaw. This is especially true for heterogeneous materials and for the formation of multilayer structures. Therefore, it is necessary to precisely control the heat supply, temperature and pressure during the drying stage.

#### 4.5. Drying endpoint and ventilation

The crude mark of the drying endpoint is the change of vacuum degree and cold trap temperature. After a period of drying, the temperature of the cold trap is no longer decreased, and the vacuum degree is stable to a high degree.

At this time, the vacuum pump can be closed, and the drying chamber can be ventilated through the vent valve.

**Finally close the dryer and take out the sample.**

#### 4.6. Defrosting

The ice can be removed by room temperature or blower.

## 5. Installation and operation

### 5.1. Components



**Fig.1-1 Main dryer**

- 1. USB
- 2. Power Supply Switch
- 3. Display Screen
- 4. Transparent door . Vacuum interface
- 6. Water discharge and inflation valve

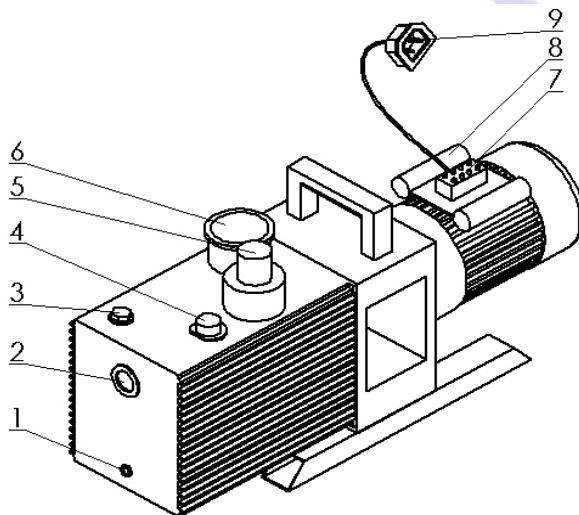

**Fig.1-2 Vacuum pump**

- 1. oil outlet
- 2. oil level
- 3. oil inlet
- 4. Gas ballast valve
- 5. air outlet
- 6. air inlet
- 7. terminal
- 8. capacitor
- 9. power plug

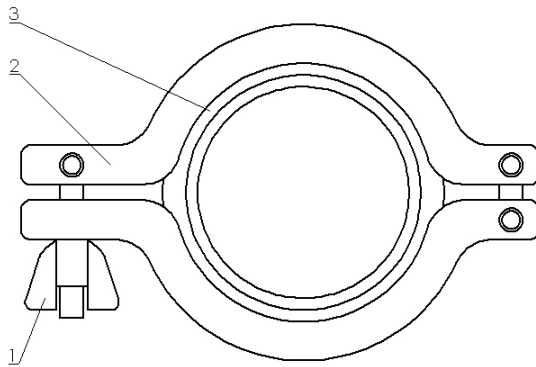

**Fig. 1-3 connector**

1、 nut 2、 bracket 3、 seal ring

## 5.2. Attention when installation and testing



### Warning:

- Paper, cloth, or similar materials do not near the gas circulation pathway or heat exchange may be blocked.
- Freeze dryer should be placed horizontally, ambient temperature is about +10°C~32°C.
- The clearance between dryer and wall should be more than 40cm, to keep enough air flow. Never near the heater or other heat source. Never be in sunlight directly.
- The lack of air circulation or the high ambient temperature can lead to the pressure or temperature of the refrigeration system higher, or even more than the allowable operating pressure. It will be led to failure.

### 5.2.1 Power source

The local power supply must be the same with the shown in nameplate.

### 5.2.2 Fuse

The fuse should be 16A.

### 5.2.3 condensation and defrost

The condensed water is discharged through the discharge valve below the freeze dryer.

### 5.2.4 Vacuum exhaust device

We recommend to use exhaust filter (oil mist filter). This filter can prevent the air pollution caused by the oil mist from the vacuum pump. The amount of oil mist from the vacuum pump depends on the pressure of the working. The filter is installed on the exhaust flange of the vacuum pump, which is equipped with a safety valve to indicate the saturated state of the filter.

### 5.2.5 Start to running

Note: the correct installation of the freeze dryer must be check before starting.  
Check and confirm that the vacuum pump oil has been added before starting.



Fig. 1-4 Connecting

### 5.3. Installation step

- (1) Open the package, check the components according to the packing list;
- (2) Fill the pump's oil into pump to the middle of the level guide.  
Remark: Please using required oil type;
- (3) Connect the pipe between pump and dryer by connectors. One side is fixed on pump's air inlet, the other side is fixed on dryer's vacuum outlet;
- (4) Connect the pump's power plug into dryer's vacuum pump power outlet;
- (5) Connect the power wire to dryer's main power outlet, other side connect to power supply (with ground wire).
- (6) Turn on the switch, test step by step according to the instructions. When all the technical data are satisfied (including vacuum  $<15\text{Pa}$ , condenser chamber's temperature  $<-35^{\circ}\text{C}$ ), the dryer could be put into usage.

### 5.4. General operation process of freeze drying

- (1) Connecting the freeze dryer correctly according to section 5.3;
- (2) Adding sample into disc (liquid sample is poured directly, solid sample or bottled sample is distributed).
- (3) Putting disc on the tray, to ensure they are completely coincided. Closing the door and locking the handle;
- (4) Turning on the switch and getting in main interface;
- (5) In control interface, touching main interface button and getting in;
- (6) In main interface, touching user parameters button and getting in;
- (7) In user parameters interface, could setting drying process, including stage number, temperature and time for each stage;
- (8) Touching back to control interface. Touching button to start temperature control and freeze system to ensure the sample's temperature is changed following setting values. In drying process, stage one is pre freezing stage. The sample will be frozen to below Eutectic point, and make sure the sample

has been frozen totally;

(9) When pre freezing stage finished, the process getting into drying stages (stage two and later stages). Open vacuum pump, making vacuum condition in chamber, to dry the sample. Make sure all the vent valves had been closed;

(10) When all stages finished, it means the drying process is over. \*

Open the vent valve at first, then close vacuum pump, close temperature control and freeze system. Finally, turn off the power and take off the power plug. While the pressure balance between chamber inside and outside, open the door, take out sample.

(11) Defrosting the ice by heater. After all the ice removed, clean the dryer. \*\*

\*Note: Due to the specific characteristics of the material, and the thickness of the material is different, the user should be tested to determine the appropriate freeze-drying process to ensure that the material is completely dry.

\*\*The outlet of the vacuum pump should be cover to avoid dust entering.

## 6. Control system operation

The dryer's control system is operated through touch screen. Please read the instructions carefully so as to use them correctly and keep them properly for reference.

### 6.1 Operation attentions

(1) In case of fire, explosion or machine damage, it is forbidden to use flammable, explosive gas and steam places.

(2) In order to prevent electric shock or instrument failure, the power can be connected to power supply only after all the wiring completion finished. It is not allowed to touch the interior and change the instrument.

(3) Except user parameters, other parameters have been set up before the factory, do not arbitrarily change.

(4) Before cleaning. Clean power meter display with a soft cloth or cotton paper please. The display is easy to scratch, prohibit the use of hard objects wipe or touch the screen.

### 6.2 Control system interface and parameter setting of NovaDryer-HF600

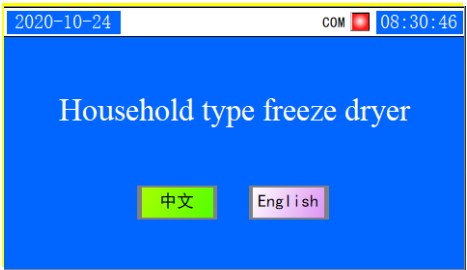
Home page & Name	Operation	
	Home Page	This interface is used to switch between Chinese and English

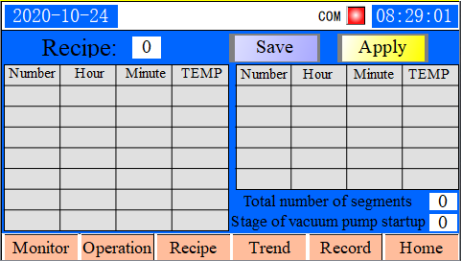
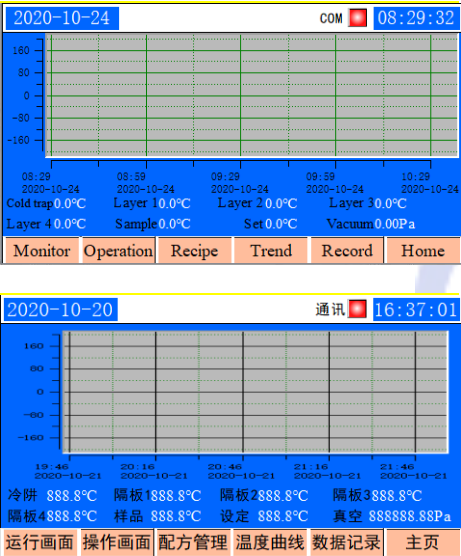
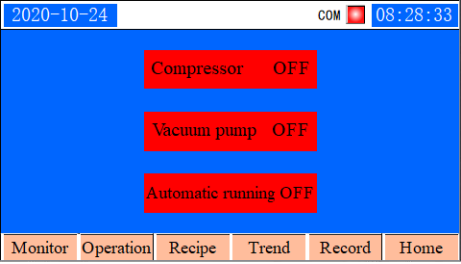

	<p>Recipe management</p>	<p>In the interface, you can set the process you need, but most of them do not require you to set up. We will prepare most of the parameters for you to adapt to the equipment. The only you need to operate is the temperature control curve (The temperature and maintenance time that need to be controlled during the drying process). More detailed setting methods, please read sop</p>
	<p>Temperature curve</p>	<p>On this interface, the process curve of the device can be seen, or it can be displayed in the form of a report. After inserting the USB flash drive, the data can be exported. It should be noted that the touch screen has limited RAM and you need to clean the RAM regularly every month</p>
	<p>Operation screen</p>	<p>After the formula is selected, directly enter the operation screen, click the "refrigerator on", and then click on the "automatic operation on".</p>



		Data Recording	Record freeze-dried data, which can be exported to U disk
--	--	----------------	---

### 7. Attentions

- 1、 Must use a grounded power outlet.
- 2、 Working environment temperature  $\leq 32^{\circ}\text{C}$ , the humidity  $\leq 80\%$ .
- 3、 After drying finished, open the vent valve to inflate air at first, then close the vacuum pump to prevent sample contaminated by the pump oil. If a sudden power outage, open the vent valve immediately, and take out the samples as soon as possible, properly stored.
- 4、 Keep the seal ring clean, and cannot Scrub with organic solvents.
- 5、 Replace the vacuum pump's oil after working 100 hours, check and maintenance the pump regularly.
- 6、 Do not frequently switch power supply and refrigerator, If the refrigerator is shut down caused by operation, at least three minutes to wait, and then restart the refrigerator.

### 8. Common trouble and shooting

The vacuum cannot less than 15Pa	1	Check the connecting between vacuum pump and dryer, if the connector fitting correct and tightened?
	2	Check vent valve, if closed totally?
	3	Check the seal ring, if fitting, correct?
	4	Check the vacuum pump working condition, if the oil clean?
Vacuum pump injection	1	Check if some valve not closed, the chamber not in seal condition.
	2	Check if the pump oil level too high, the normal position is the middle of the gauge.
	3	Check if the pump oil emulsion?
	4	Check if the condenser's temperature too high, the pump should be start after the temperature lowered.

### 9. Warranty and maintenance

- 1、 The dryer is warranty for one year from the date of sale.
- 2、 The dryer is full life maintenance by our company.