



Deep Freezer

Model YR05307

## Instruction Manual

Thank you very much for purchasing our Kalstein's Deep Freezer Model YR05307

Please read the "Operating Instructions" and "Warranty" before operating this unit to assure proper operation. After reading these documents, be sure to store them securely together with the "Warranty" at a hand place for future reference.



**Warning:** Before operating the unit, be sure to read carefully and fully understand important warnings in the operating instructions.



OUR SERVICES

## Benefits and Support

In Kalstein France, we take care of the full satisfaction of our customers, that is why we provide value-added services of the highest level based on our experience.



### Online Inductions and Trainings

In any part of the world, receive your induction or training from our specialized team of engineers



### Quick Response

Our work team is always available to response all your consults or questions, in order to support you in any situation.



### #Letsgivemore

Thanks to your purchase, a donation will be made to a non-profit foundation that fights against breast cancer and helps most vulnerable communities.



### Technical Support

Enjoy of personalized advice for the correct preventive and corrective maintenance of your equipment, thanks to Kalstein's manuals and articles, special catalogues and video tutorials.



### Delivery Logistics

We take care of all the necessary logistics for the dispatch of your goods, whether is by sea, land or air.



### Kalstein Worldwide

With more than 25 years growing with our customers, Kalstein's multiformat and modern content, is now present in more than 10 countries and increasing.





## Statement:

Thank you for choosing and using the products of our company. (hereinafter referred to as our). For your safety, convenient use and reasonable maintenance of this product, please read the instructions carefully before use and keep them for reference.

The user shall be responsible for any damage to the instrument caused by the user's failure to comply with the requirements of this manual, or for any injury caused by the user's failure to comply with the requirements of the "Safety Tips".

Please follow the Safety tips:

1. Use protective equipment (including clothes, gloves, goggles, etc.) correctly;
2. Keep good hygiene and strictly follow product instructions;
3. Everyone is responsible for his own safety.
4. Patients are not allowed to directly touch, use or affect the products or the stored items in the products;
5. The product has not been sterilized;
6. The product is only used for storage and shall not be used in combination with other materials, organizations or technologies during use;
7. The product shall not be used for measurement or analysis;
8. The product's life is not equal to the storage life;
9. Some models need to add consumables regularly, such as printing paper and test tubes;
10. This product is not a explosion-proof equipment;
11. This product is not a quick-freezing equipment, this is only used to maintain temperature.

Due to the rapid update of our products, if the functions described in this manual are different from those of the products you purchased, please refer to the physical functions.



# CONTENTS

I. Cautions .....	4
II. Preparation and attention before use .....	8
III. Instructions for use .....	9
3.1 First use .....	9
3.2 Product Structure .....	11
3.3 Temperature Adjusting(ONE) .....	13
3.3.1 Button Function .....	13
3.3.2 Parameter Settings .....	14
3.3.3 Setting for Temperature Checking .....	14
3.3.4 Time Setting and Checking .....	16
3.3.5 Alarm Code .....	16
3.3.6 Error display .....	16
3.4 Temperature Adjusting (TWO) .....	18
3.4.1 Button Function .....	18
3.4.2 Parameter setting .....	19
3.4.3 Alarm code .....	19
3.5 Temperature setting(Three) .....	19
3.5.1 Key functions .....	20
3.5.2 Parameter setting .....	20
3.5.3 Time query settings .....	21
3.5.4 USB data download and settings .....	23
3.5.5 Alarm code .....	23
3.5.6 Error display .....	23
IV. Daily Maintenance .....	24
4.1 Clean of freezer .....	24
4.2 Defrost .....	25
4.3 Care and Maintenance .....	25
V. Troubleshooting .....	25
VI. Main Performance Data .....	27
6.1 Product Structure and made up .....	27
6.2 Main Technical Data .....	27
6.3 Electrical schematic diagram .....	28
VII. Packing List .....	31



# I. Cautions

- ❖ Please follow the notes and regulations in this manual to avoid possible injury to the user and any other person.
- ❖ "Warning" and "Prohibition" are indicated as follows:

 The contents with the "warning" mark are related to the product safety and the personal safety of users, and must be operated strictly according to the warning content.

 Any content bearing the "Do Not" sign must be absolutely prohibited, otherwise it may cause damage to the freezer or endanger the personal safety of the user.

- ❖ Please read this manual carefully when using this machine for the first time.
- ❖ This product can only be operated by trained and authorized personnel.
- ❖ Equipment maintenance can only be completed by our or its authorized agent.
- ❖ If the operator encounters any situation not mentioned in this manual, please contact our or the agent authorized by our to ask for the correct handling method.
- ❖ Please use the accessories provided by our. If the user wants to use other accessories, our will not be responsible for the adverse consequences. However, users can apply to our to verify whether the accessories meet the requirements of our.
- ❖ The product must be inspected and maintained at specified intervals.
- ❖ The freezer is strictly prohibited to store living creatures or other items that are strictly temperature-dependent and not suitable for constant temperature storage.
- ❖ The freezer will naturally dissipate heat through the rear surface (condenser) or the cooling fan to achieve the purpose of refrigeration. In order to ensure the normal operation of the machine and ventilation and heat dissipation, the back and sides of the box shall be at least 30 cm away from the wall, and the air inlet and outlet shall not be obstructed by obstacles.
- ❖ The production date is shown in the bar code. The first and second digits of the bar code represent the year, the third and fourth digits represent the batch number, the fifth, sixth, seventh and eighth digits represent the number of products, the ninth and tenth digits represent the month of product production, and the other digits represent the product model.
- ❖ Service life: 10 years; See batch number for production date.
- ❖ The temperature in the cabinet will rise when power failure. If it cannot be repaired within a short period of time, please take out the storage items and transfer them to other places that meet the temperature requirements of the storage items for storage, so as to avoid damaging the storage items.
- ❖ Equipment may not have SMS alarm and remote alarm functions, must arrange staff on duty 24 hours a day and 24 hours a day uninterrupted patrol, otherwise it may happen equipment malfunction alarm cannot be found, which can lead to store items due to over temperature metamorphism.
- ❖ User can adjust the temperature of the product according to their own needs in the allowed national standard range.
- ❖ If the thermostat has keyboard lock function, lock the keyboard after the adjustment to avoid errors caused by incorrect operation set temperature which might leading to store items metamorphism.
- ❖ Do not try to enter the secondary Settings menu in using, otherwise it may affect the normal work of the product, and even cause the damage of the product.
- ❖ If the product service time longer than the product life, this product needs to increase the frequency of maintenance, inspection



records, needs to contact professional and technical engineer from manufacturer to do regular check.

- ❖ User should comply with product specifications and product itself with hints of labeling and warning labels for the operation or may be dangerous or cause performance degradation.
  - ❖ Product does not exist, liquid chemicals, waste emissions.
  - ❖ Products does not involve the stored goods storage life.
  - ❖ Product does not involve extending and (or) use for a long-time effect.
  - ❖ This product is a disposable product, no need does sterile processing.
  - ❖ Put on the gloves to avoid touching the sharp edges or corners and injured during repairing.
  - ❖ Unplug the power plug, when stop using for a long time. In case the aging of the power cord leads to electric shock, leakage or fire.
  - ❖ Check the Settings after a power outage or shut off the power to restart the device. Changes to Settings may damage saved items.
  - ❖ If equipment operation is not normal, please unplug the power plug. If the operation continues under abnormal conditions, it may cause electric shock or fire.
  - ❖ Before this equipment for any repair or maintenance, be sure to disconnect the equipment power supply, to prevent electric shock or injuries.
  - ❖ Ensure no suction of drug or suspended solids inside and around the equipment when maintenance.
  - ❖ Only qualified technicians could install the equipment. Installation by unqualified personnel may result in electric shock or fire.
  - ❖ Make sure this equipment is firmly installed on solid ground. If the ground is not secure or improperly placed, equipment may tip over or cause injury if the ground is not smooth.
  - ❖ Please use earthed power socket to prevent electric shock. If the socket is not grounded, the grounding wire must be installed by a qualified engineer.
- ⓘ Equipment may not have SMS alarm and remote alarm functions, must arrange staff on duty 24 hours a day and 24 hours a day uninterrupted patrol, otherwise it may happen equipment malfunction alarm cannot be found, which can lead to store items due to over temperature metamorphism.
- ⓘ User can adjust the temperature of the product according to their own needs in the allowed national standard range.
- ⓘ If the thermostat has keyboard lock function, lock the keyboard after the adjustment to avoid errors caused by incorrect operation set temperature which might leading to store items metamorphism.
- ⓘ Do not try to enter the secondary Settings menu in using, otherwise it may affect the normal work of the product, and even cause the damage of the product.
- ⓘ If the product service time longer than the product life, this product needs to increase the frequency of maintenance, inspection records, needs to contact professional and technical engineer from manufacturer to do regular check.
- ⓘ User should comply with product specifications and product itself with hints of labeling and warning labels for the operation or may be dangerous or cause performance degradation.
- ⓘ Product does not exist, liquid chemicals, waste emissions.
- ⓘ Products does not involve the stored goods storage life.
- ⓘ Product does not involve extending and (or) use for a long-time effect.
- ⓘ This product is a disposable product, no need does sterile processing.
- ⓘ Put on the gloves to avoid touching the sharp edges or corners and injured during repairing.



- ⓘ Unplug the power plug, when stop using for a long time. In case the aging of the power cord leads to electric shock, leakage or fire.
- ⓘ Check the Settings after a power outage or shut off the power to restart the device. Changes to Settings may damage saved items.
- ⓘ If equipment operation is not normal, please unplug the power plug. If the operation continues under abnormal conditions, it may cause electric shock or fire.
- ⓘ Before this equipment for any repair or maintenance, be sure to disconnect the equipment power supply, to prevent electric shock or injuries.
- ⓘ Ensure no suction of drug or suspended solids inside and around the equipment when maintenance.
- ⓘ Only qualified technicians could install the equipment. Installation by unqualified personnel may result in electric shock or fire.
- ⓘ Make sure this equipment is firmly installed on solid ground. If the ground is not secure or improperly placed, equipment may tip over or cause injury if the ground is not smooth.
- ⓘ Please use earthed power socket to prevent electric shock. If the socket is not grounded, the grounding wire must be installed by a qualified engineer.
- ⊗ Patients shall not use or control this product.
- ⊗ Patients do not touch or approach the product in any way.
- ⊗ Do not directly contact, store any biological material with this product.
- ⊗ No inspection, measurement or analysis by this product
- ⊗ No stirring, crushing processing by this product.
- ⊗ Please don't use this product with other materials, components, technologies and medical equipment, neither contact with the medical apparatus and instruments. Products don't have the function of the treatment or therapy.
- ⊗ Product doesn't have the function to improve the state or the activity of storage items.
- ⊗ This is not a fast freeze Product, only used to store organs, materials or goods which have temperature requirements with the requirements of stored items with packaging or containers.
- ⊗ This is not a product with disinfection and sterilization function or absolute sealing, no vacuum or negative pressure inside. No isolation function of radiation, toxic, radioactive, infectious items shall be stored.
- ⊗ No pulling, tight, processing, trample, extrusion, damage nor distortion the power cord, to avoid the leakage damage and even fire caused by the loosen power cord.
- ⊗ No obstacles stuck in door seals to cause frost or ice which would lead to performance degradation.
- ⊗ Do not put power cord directly to the ground, to avoid leakage accidents.
- ⊗ Do not touch the compressor room or top of freezer to avoid any electric shock risk.
- ⊗ Do not storage too wet items or it may cause heavy ice or frost on evaporator to affect the performance of refrigeration □
- ⊗ Do not storage too hot items or it may cause high temperature inside cabinet to damage other items inside.
- ⊗ It is strictly prohibited anyone enter into this product, especially children. If the device is left unused in an unsupervised area for a long period of time, make sure that the device is not accessible to children and the box is not completely closed.
- ⊗ Do not use wet hand contact with any electrical parts such as power plug or switch, otherwise may cause electric shock.
- ⊗ Don't put the containers of liquid or heavy objects on the equipment. If the item drops, it can cause injury, and the outflow of liquid can reduce the degree of insulation and cause leakage or electric shock.
- ⊗ Do not be preserved in this box of each surface drilling, otherwise will seriously affect the performance of refrigeration preservation.



- ⊖ Do not use of the equipment in open air. When the product is wet by rain, it may cause electrical leakage or electric shock.
- ⊖ This equipment must not be placed in wet places or vulnerable to splash water. Otherwise, it will cause leakage or electric shock accidents due to reduced insulation degree.
- ⊖ Do not be store inflammable, explosive or volatile hazardous goods, also cannot be used near flammable spray, otherwise may cause fire or explosion.
- ⊖ Do not be store acid, alkali and so on easy to corrosion items. Otherwise, it may damage the internal components or electrical parts of the equipment.
- ⊖ Do not insert the metal objects such as nails or wire any orifice and clearance of the equipment or any outlet for internal air circulation, otherwise you will get an electric shock caused by the above objects come into contact with moving parts or injured.
- ⊖ Do not pull the liquid on the product shell or inside, otherwise may damage the electrical insulation and cause failure.
- ⊖ Do not be removed, repaired or modified equipment by unprofessional workers. If any of the above operations are carried out by unauthorized person, there is a risk of fire or injury due to improper operation.
- ⊖ Don't climb on the device or items on the equipment, otherwise it will be caused by equipment overturned personnel injury or equipment damage.
- ⊖ Equipment scrap disposal should be performed by the appropriate person. Be sure to remove the door to prevent children from entering the box.
- ⊖ If the device and its associated packaging materials and parts are scrapped, please ask the relevant departments and person, the equipment and its associated packaging materials and product has no toxic and harmful substances, won't cause pollution to the environment.
- ⊖ Do not put plastic package accessible to children.
- ⊖ please use product in safety area when store moderately, harmful or radioactive substances. Improper use may cause harm to human health or the environment.



: It is used to warn the user that there may be a danger of pinching hands in the gap of product door when opening and closing.



: It is used to warn the users that electrical components and connecting wire terminals in the cabin may be in danger of electric shock.



: Used to warn users that products should stay away from fire sources.



: Used to warn users that the product fan may be in danger of hurting hands when taking items.



: To remind user to put sensor inside box to avoid inaccuracy display.



: To warning not put items over this line to affect inside temperature



: To warning not put items over this line to affect inside temperature





## II. Preparation and attention before use

- ❖ Transport: the freezer should be uplifted from the bottom and carried and put down lightly. The inclined plane should be no larger than 45 degrees.
- ❖ After installation, keep the device standing for 12 hours at least to return the compressor oil.
- ❖ After installation and first use testing, please adjust the castors to fix the device.
- ❖ Do not hold the door or the lining port as stressed member.
- ❖ Dismantle all package components (including protection foam in the freezer body).
- ❖ Please check accessories and data according to the packing list.
- ❖ Please clean the product before use.

### Operating environment requirements:

- a. For indoor use only.
- b. The mounting surface must be fixed, horizontal and incombustible and be able to bear weight during the operation of the freezer.
- c. To be placed away from direct glare of sunshine and heat and the environmental temperature should be not higher than 32°C. Humidity: lower than 80%.
- d. Space of above 30cm is required to be left around the freezer for ventilation and heat dissipation.
- e. Not allowed to be placed in the environment under 0°C;
- f. Not allowed to be placed at places with heavy moisture or easy-splashing water.
- g. On flat ground, the medical freezer or can be directly pushed to move.
- h. Ambient noncorrosive, flammable, explosive gas, liquid or dust.
- i. The surrounding environment must be kept well ventilated.

ⓘ Notes: please note that do not let the power line be damaged by trundles when pushing the freezer.

ⓘ Notes: be sure to take off the packaging pedestal on the bottom of the freezer.

ⓘ Notes: Do not put goods into the freezer which is just plugged in. Let the empty body run for a while (about 12 hours) and then put the goods to be refrigerated into the freezer.

### Safety precautions:

- The power supply should be equipped with low-voltage air breaker and leakage protection device during usage.
- Please use the special power supply indicated on the nameplate of the equipment. If the voltage is lower than 198V or higher than 242V, it is necessary to install appropriate automatic voltage regulator to cooperate with the use. If the power cord needs to be extended, the cross-sectional area of the extension cord shall not be less than 2.5mm<sup>2</sup> and the length shall not be longer than 3m. The use of any voltage or frequency power supply other than those indicated on the nameplate may cause damage to electrical components or fire.
- The key should be kept properly to avoid accidents when children open the door after getting it.
- Do not connect the zero wire (N end) on the socket with the grounding wire (E end), otherwise it will cause the shell of the freezer to be charged and electric shock will occur.



- The power cord should not be tied, pressed under heavy objects, or close to heat sources such as compressors.
- Do not open and close the door too fast, which may lead to increased difficulty in opening the door and loose door closure.
- The open times of doors should not be frequent in use. The interval between door's open should be more than half an hour to avoid frost in the evaporator and the inner wall of the box.
- Please immediately disconnect the power supply in case of electrical faults such as leakage or short circuit during use.
- One power socket shall be used independently for each freezer, and the current of the power socket shall be no less than 10A, and the power socket shall be reliably grounded.

#### **Attention in Use:**

- Open the box for no more than 1 minute at a time and wipe the ice water on the door seal before closing to ensure good sealing effect.
- When there are more items, please store them in batches, each batch shall not exceed one third of the box volume. After the first batch of items is put in, put the second batch after the displayed temperature is stable to ensure that the temperature in the box is stable.
- During the use of the freezer, if the items are opened for too long, the external hot air will enter the box and cause the high temperature alarm. This is a normal phenomenon. Please pay attention to minimize the time and times of opening and closing the door.
- In order to extend the service life of the freezer and reduce energy consumption, on the premise of ensuring the safety of the storage items, it is suggested to refer to the warm reminder for the temperature setting of the freezer.
- If the freezer does not cool after 2 to 3 hours of power on, please unplug the power and contact the customer service as soon as possible.
- The freezer is suitable for storing items and should not be used as a quick-freezing box. It cannot be forced to freeze a large number of hot items or large volume liquid items quickly, which will cause the compressor to not stop for a long time, and the temperature will not drop, and it is easy to burn the compressor.
- In case of alarm fault or other fault, please refer to the instruction manual and remove the fault according to the prompts on the display board. If the fault cannot be removed by yourself, please do not disassemble without authorization. Please contact after-sales maintenance personnel to help eliminate the fault in time.
- Clean the condenser dust every three months to ensure the normal operation of the equipment.
- Do not open the electric control box if you are not the maintenance personnel of our company.

## **III. Instructions for use**

### **3.1 First use**

Use the installation.

1. Remove the packing materials and bags.

Remove all transport packing materials and bags.

2. Check random attachments.

Please check the contents in the box according to the packing list. If there is any discrepancy, please contact the after-sales service in time.



### 3. Placing conditions

A 30 cm gap should be left around the freezer to facilitate ventilation and heat dissipation.

### 4. Fixed freezer

The brake of the universal wheel of the product is locked. If the product has adjusting feet, turn the adjusting feet clockwise to support it on the ground. Make sure the save box is not moved when in use.

### 5. Fixed backup limit support

The backup support in the product attachment is fixed on the box body through the screw hole reserved in the backup freezer (as shown in the figure).

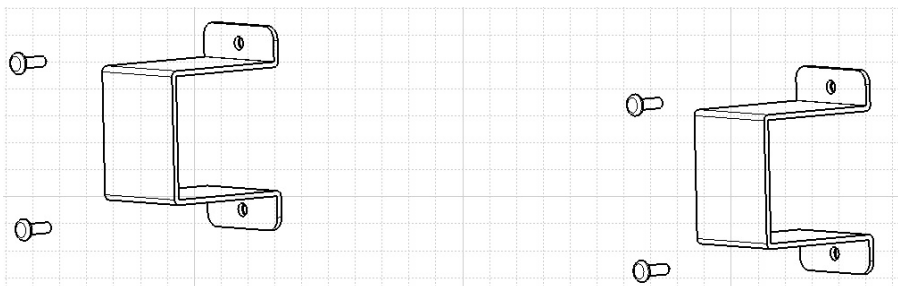

Ground warning:

An electrical outlet with a grounding wire should be used. If the power socket is not grounded, the grounding wire must be installed by a qualified engineer.

Do not use gas pipe, water supply pipe, telephone line or lightning rod to ground the equipment, to prevent electric shock.

### Adjusting:

Please Follow the steps when you use the equipment for the first time:

- 1) Connect the power cord to the dedicated socket as described above.
- 2) After power on, turn on the power switch (for YR series, press the power button for 5 seconds on the temperature control panel, and for YR series, turn on the power switch on the back of the box). At this time, the temperature controller displays the temperature in the box.
- 3) Press the mute button to stop the beep if you hear the alarm.
- 4) Set the required temperature of the freezer: no items should be put into the empty box. Observe the normal operation of the freezer for more than 24 hours.
- 5) After confirming the normal performance of the freezer, you can store the items in the freezer.

### Do Nots:

- Do not use any mechanical tools or other means of defrosting that are not approved by the manufacturer.
- Do not damage the refrigeration circuit.
- Do not use electrical appliances inside the freezer.

### Operation after power outage

The freezer has the function of memory for the set value. When the power is cut off and the power is called again, the equipment will continue to run according to the set parameters before the last power is cut off.

### Note:



- ❖ The container has been cleaned when leaving the factory, but it is still recommended to wipe the container with warm water and a small amount of neutral detergent, and then wipe it with clean water and dry it (electrical parts cannot be cleaned and can only be wiped with a dry cloth).
- ❖ The parameters of the temperature controller of the freezer have been set when leaving the factory, and the power will be switched on. After 3 minutes, the compressor will start. After 30 minutes, the temperature in the freezer drops, indicating that the refrigeration system works normally, and the test machine is over.
- ❖ For the first use, it is recommended to put the items to be stored in the box after the temperature in the box drops to the operating temperature. If you store too many items, it is recommended to store them in three batches. Wait for the temperature in the box after the previous storage to drop to the set temperature, and then store again. Excessive storage at one time may cause the freezer to fall below the set temperature for a long time, causing damage to the goods.
- ❖ In order to save electricity, the number and time of opening doors should be minimized.

### 3.2 Product Structure

YR05293/ YR05294, YR05306/ YR05307

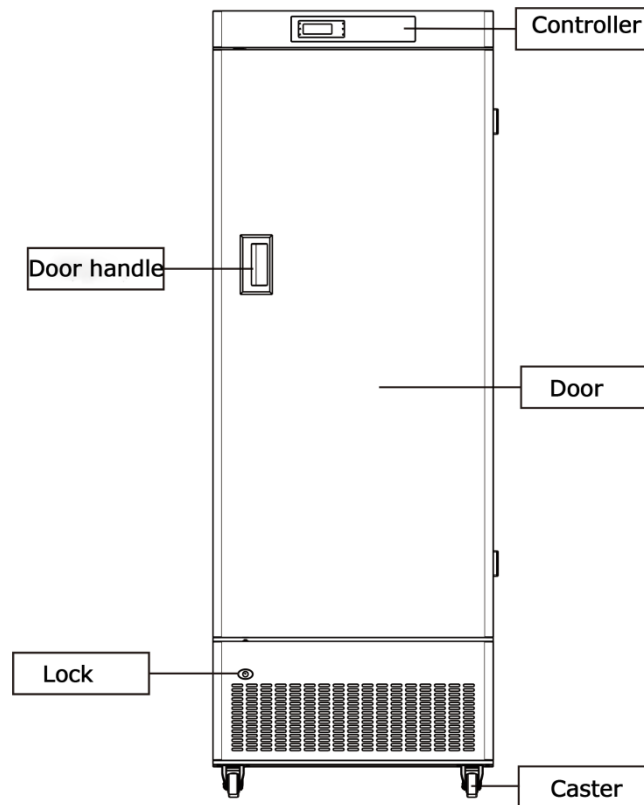

YR05308/ YR05097

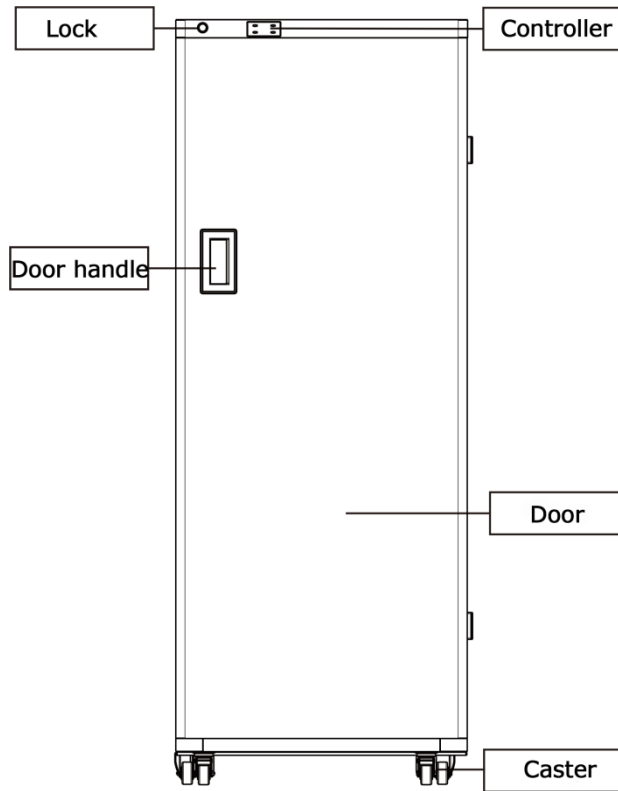

YR05309/ YR05311

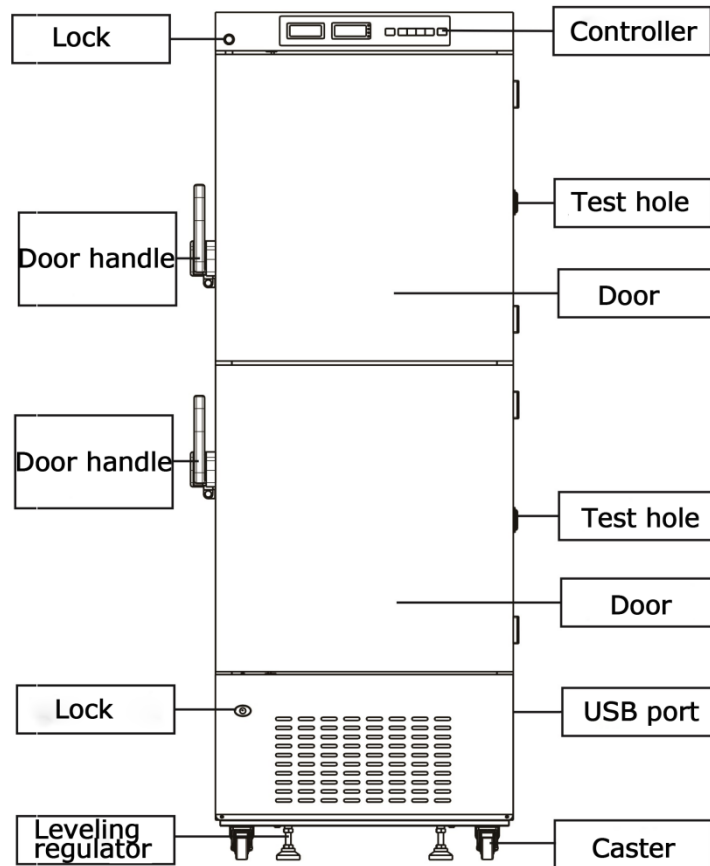

YR05100/ YR05310

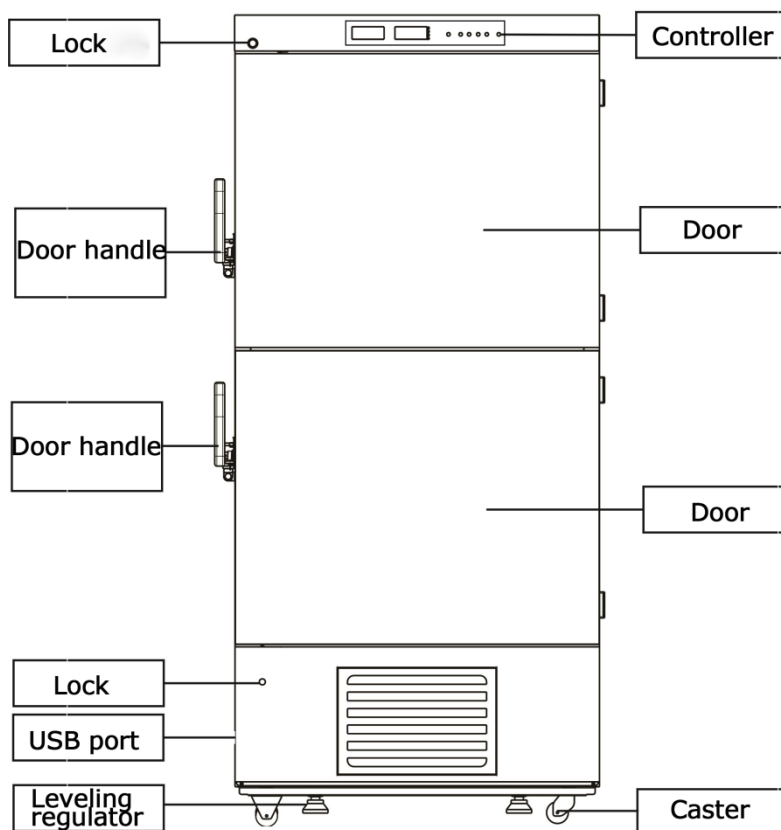

### 3.3 Temperature Adjusting (ONE)

#### 3.3.1 Button Function

YR05293/YR05294, YR05306/ YR05307

Controller would display the inner cabinet temperature; the controller panel would display as below:

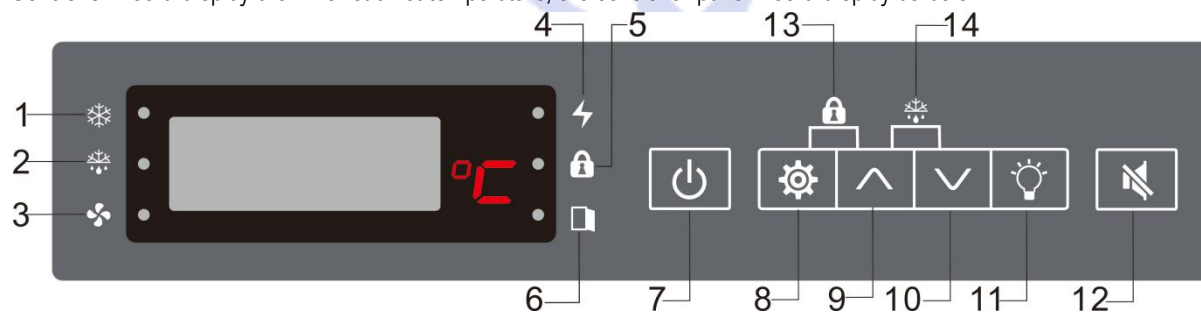

1. Cooling status indicator
2. Defrost indicator.
3. Fan status indicator
4. Power indicator
5. Keyboard lock indicator
6. Door open indicator
7. Power switch
8. Setting







- 9. Up
- 10. Down
- 11. Lamp switch
- 12. Mute
- 13. Keyboard lock (Combination)
- 14. Defrost (Combination)

Do not change the set temperature randomly during normal use. The product will not work when press the power button for 10 seconds which will turn off the product's power supply. Press the power button for 10 seconds again and the product will continue to work normally. Press the keyboard lock key for 10s to lock the key. At this point, the keyboard lock indicator lights up and all keys become invalid. Press the keyboard lock for 10s again to unlock the key. You can press the mute button to cancel the alarm sound, but the alarm indicator light and the alarm code will be displayed until the alarm state is canceled. If there is any special need for adjustment, please call the after-sale service or be adjusted by professional maintenance personnel. If the set temperature is adjusted at randomly, it may cause the alarm of high temperature (AH) or low temperature (AL) of the product.

### 3.3.2 Parameter Settings



When power on the medical freezer, the display screen displays internal temperature value. To change setting temperature, for example, the original set temperature is -30°C which now has to be adjusted to -40°C, please operate according to the following steps:

No.	Keys Operation	Display
1		Displays the inside temperature
2	Press the key Set  for 3 seconds	Displays the initial set data is -30°C and twinkles
3	Press the key Up-regulation 	Figure increases
4	Press the key Down-regulation 	Figure decreases
5		Figure is -40°C
6	Press the key Set  for 3 seconds	Saves the user settings and displays the inside temperature







Notes: If any parameters need to be changed, please contact after-sale or local distributor of us for setting.

### 3.3.3 Setting for Temperature Checking

When normal working, press  check high and low temperature record. Such as current time is 9:20 on the afternoon of Mar 15th, 2017, record the high temperature of 6.7 °C, at 15:23 record the low temperature of 3.9°C, and the cycle. No operation is larger than that of 5S showed normal temperature. The query is shown below:

NO.	key operation	Display
1		Display cabinet temperature
2	press 	Display highest temperature 6.7°C
3	Press again 	Display HT date HD20



4	Press again 	Display HT hour HH09
5	Press again 	Display HT minute HE30
6	Press again 	Display lowest temperature3.9
7	Press again 	Display LT date LD20
8	Press again 	Display LT hour LH14
9	Press again 	Display LT minute LE25
10	Press again 	Display highest temperature6.7°C

Note: When normal display long press  5s, to delete a record high and low temperature data, check high and low temperature data at this time, showing "00", time display code +00, such as "HD00". The current data logging time interval is 10min, the default is 17:35 minutes to clear records of high and low temperature data. please contact after-sale or local distributor of us for setting.







### 3.3.4 Time Setting and Checking

When normal working, press check time record, such as current time is 20:20.21 on the afternoon of Mar 15th, 2017.

NO.	key operation	Display
1		Display cabinet temperature.
2	Press	Year Y_17
3	press again	Month N_03
4	press again	Date D_15
5	press again	Hour H_20
6	press again	Minute E_20
7	press again	Sencon S_21

Note: When normal display long press 5s, can adjust the current time. When normal display, press 5s, flickering display of Y\_17, through press or set current year, then press flickering display of N\_03, through or set the current month, repeat these steps after you have set the time accordingly, long time press can save time settings.

### 3.3.5 Alarm Code

NO.	Alarm Code	Alarm Description
1	AH	Cabinet high temperature alarm
2	AL	Cabinet low temperature alarm
3	AUF	Power Failure
4	ADO	Door ajar alarm
5	ABL	Low Battery
6	AD1S	Defrosting _ display probe malfunction
7	AD1B	Defrosting _ display probe a short circuit
8	AS1S	Control probe 1 malfunction
9	AS1B	Control probe 1 shorted

### 3.3.6 Error display

- ❖ When faults of the freezer temperature display sensor including short circuit, open circuit, malfunction and incorrect connection appear, "AD1S" is displayed. When faults of the freezer temperature control sensor including short circuit, open circuit, malfunction and incorrect connection appear, "AS1S" is displayed. At the same time, the buzzer of the temperature controller will give out alarm and the display screen displays corresponding alarm parameters (AD1S、AS1S).
- ❖ After the power is switched off, the control function of the controller fails, and the back-up source is used for displaying. If the back-up source is charged for more than 10 hours, the power failure symbol "AUF", the current inside temperature and the alarm display alternatively for one time and then display again after 1min stop for cycle operation. After 8 hours, the Digital screen stops displaying.



The power failure alarm light will 5S twinkle continuously until the electric quantity of the back-up source is used up. The inside temperature can be continuously displayed during the power failure. Please pay attention to this and take relevant measures to avoid damage.

- ❖ Reminder: Please wait for 1 minute to operate when controller shows parameter code, till the current temperature shows again, to avoid malfunction caused by control parameter changes.
- ❖ When the medical freezer stops temporarily due to power failure or other faults, the inside temperature of the medical freezer will rise from  $-40^{\circ}\text{C}$  to  $-30^{\circ}\text{C}$  within 1 hour. If power cannot be supplied in short time, the user should consider taking out the stored goods and putting them into other normal medical freezers for storing to avoid losses caused by the damage of the stored goods.
- ❖ Before putting goods into the medical freezer to be stored, the user should confirm in advance that whether inside temperature of the medical freezer is in accordance with the set temperature for storing to avoid losses caused by goods damage due to the improper temperature.
- ❖ Due to the refrigeration inertia, the medical freezer cannot be kept at constant temperature. And there is certain up and down difference between the inside temperature and the set temperature. The inside temperature varies with the changing of the environmental conditions and the temperature set. It belongs to normal phenomenon.
- ❖ Advice: Please power off when the temperature sensor is suspected to be broken, check the contact is loosen or not first, then contact after sale service engineer to deal with it.





### 3.4 Temperature Adjusting (TWO)

YR05308/YR05097

#### 3.4.1 Button Function

Controller would display the inner cabinet temperature; the controller panel would display as below:



Key	Functions
Set	Enter parameter setting state
	Switch menu and parameters
	Adjust menu and parameters
	Turn on/off the light (only valid for models with light controllers)
	View the temperature value of the condenser sensor
	Adjust menu and parameters
	Perform parameter one-key restore for 10 seconds
	View the evaporator sensor temperature value
	Exit parameter setting state
	Exit one-key restore state
	For 3 seconds, it is forced to switch between cooling, defrost/defrost delay, and defrost dripping.



### 3.4.2 Parameter setting

When normal display, press “Set” for 3s, display “St”, press “Set” again to enter temperature changing mode, press and to adjust setting temperature.

- Press and to choose parameters and press “Set” to enter parameter changing mode, press and to adjust.
- After finished setting, press or 30s no operation to save and exit the setting mode.
- Note: The administrator menu password input is valid once, after pressing the key to exit the parameter setting, the correct password must be entered again for the next adjustment.

### 3.4.3 Alarm code

NO.	Alarm Code	Alarm Description
1	E1	Cabinet sensor failure
2	E2	Evaporator sensor failure
3	E3	Condenser sensor failure
4	cH	Condenser high temperature alarm
5	rH	High temperature alarm
6	rL	Low temperature alarm

- Advice: Please power off when the temperature sensor is suspected to be broken, check the contact is loosen or not first, then contact after sale service engineer to deal with it.
- Reminder: Please wait for 1 minute to operate when controller shows parameter code, till the current temperature shows again, to avoid malfunction caused by control parameter changes.
- When the medical freezer stops temporarily due to power failure or other faults, the inside temperature of the medical freezer will rise from -40°C to 30°C within 1 hour. If power cannot be supplied in short time, the user should consider taking out the stored goods and putting them into other normal medical freezers for storing to avoid losses caused by the damage of the stored goods.
- Before putting goods into the medical freezer to be stored, the user should confirm in advance that whether inside temperature of the medical freezer is in accordance with the set temperature for storing to avoid losses caused by goods damage due to the improper temperature.
- Due to the refrigeration inertia, the medical freezer cannot be kept at constant temperature. And there is certain up and down difference between the inside temperature and the set temperature. The inside temperature varies with the changing of the environmental conditions and the temperature set. It belongs to normal phenomenon.
- Advice: Please power off when the temperature sensor is suspected to be broken, check the contact is loosen or not first, then contact after sale service engineer to deal with it.

### 3.5 Temperature setting (Three)

YR05100/25V528; YR05309/25V358

### 3.5.1 Key functions

Controller would display the inner cabinet temperature; the controller panel would display as below:

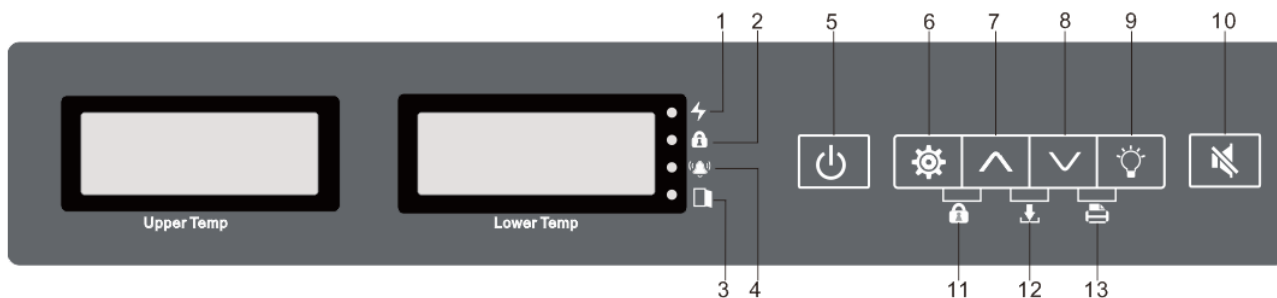

- 1.Power
- 2.Lock
- 3.Door's open
- 4.Alarm
- 5.power
- 6.Set
- 7.Up key
- 8.Down key
- 9.Light
- 10.Mute
- 11.Keyboard lock (Combination)
- 12.Data download key(Available when optional USB interface)
- 13.Printer(Combination) (Available when optional thermal printer)

- Please do not change the settings during normal using.
- Long press the power key will switch off the freezer. Long press the power button again, the freezer will work again.
- Long press the keypad lock key (combination of keys) can lock the keypad. The keyboard lock LED are lit, all the keys are locked. Then long press the keypad lock again can be unlocked.
- Press "Mute" to stop buzzing, if necessary, but the alarm indicator and code still display until the alarm disappear.
- For special using, please contact our authorized service engineer before adjusting the settings. Wrong operation may cause abnormal working of the device, such as bad temperature uniformity and abnormal high/low temp alarm.

### 3.5.2 Parameter setting

When the product is powered on, the display shows the current temperature value in the box. If you want to reset the temperature, for example, the original upper room temperature was set to -25°C, you need to adjust it to -20°C; original under room temperature was set to -30°C, now adjusted to -25°C, please follow the steps below:

Upper chamber temperature adjustment		
1	Press the set key in normal mode	"Upper Temp" flashing display current temperature "-25."



		"Lower Temp" normally display of current temperature: "- 30"
2	Press the set key again	"Upper Temp" flashing display current set value "-25", "Lower Temp" display current temperature: "- 30"
3	By the up key  or  adjust the set temperature	Change the set temperature to-20,
4	Press the set key again  save parameters	"Upper Temp" normally displays current temperature, "Lower Temp" normally displays current temperature
Lower chamber temperature adjustment		
1	Press the set key in normal mode	"Upper Temp" flashing display current temperature "-25" "Lower Temp" normally display of current temperature: "- 30"
2	And then press the up key.  switch to lower chamber temperature setting	"Lower Temp" flashing display current temperature "-30" "Upper Temp" normally display of current temperature: "- 25"
2	Press the set key again	"Lower Temp" flashing display current set value"-30", "Upper Temp" display current temperature: "- 25"
3	By the up key  or  adjust the set temperature	Change the set temperature to "- 25"
4	Press the set key again  save parameters	"Upper Temp" normally displays current temperature, "Lower Temp" normally displays current temperature



















⚠ Warning:

We advise users not to set parameters at will, there is indeed a need for parameter changes, please contact the after-sales and dealer to set

### 3.5.3 Time query settings

NO.	Key function	Display
1	Press  5s	Display the first-level parameter password 98 and flash
2	Press	Display : tE
3	Press	Display: SJ
4	Press	Display: Y (this parameter is the year)
5	Press	Display the current year



6	Press  or 	Increase or decrease the number to adjust the year setting
7	Press 	Display N (this parameter is the month)
8	Press 	Display the current month
9	Press  or 	Increase or decrease the number to adjust the month setting
10	Press 	Display D (this parameter is the date)
11	Press 	Show current date
12	Press  or 	Increase or decrease the number to adjust the date setting
13	Press 	Display H (this parameter is hour)
14	Press 	Show the current hour
15	Press  or 	Increase or decrease the number to adjust the hour setting
16	Press 	Display E (this parameter is minutes)
17	Press 	Show current minute
18	Press  or 	Increase or decrease the number to adjust the minute setting
19	Press  5s	Save the time setting and return to the main interface



### 3.5.4 USB data download and settings

In normal display mode, just press + ≥3s. At this time, if the USB flash drive has been inserted, the USB data will be exported; otherwise, if the USB flash drive is not ready at this time, the thermostat will have no response. To ensure the normal data copying, please use the USB 2.0 interface USB flash drive. The data storage interval is adjusted as follows:

NO.	Key function	Alarm Description
1	--	Display cabinet temperature
2	Press  5s	Display the first layer parameter password PS1 and flash
3	Press  adjust	Display:tE
4	Continuous short press  Adjust parameters	Display:DAG
5	Press	Display the current data saving interval
6	Press  or	Increase or decrease the number to adjust the data saving interval
7	Press  5s	Save the time setting and return to the main interface

### 3.5.5 Alarm code

Code	Description	Code	Description
AL	Low temperature alarm	E1	RT1 sensor error
AH	High temperature alarm	E2	RT2 sensor error
AHT	High ambient temperature alarm	E3	RT3 sensor error
ALT	Low ambient temperature alarm	E4	RT4 sensor error
Ado	Door ajar alarm	E5	RT5 sensor error
AUF	Power failure	E6	RT6 sensor error
AHC	Condenser high temperature alarm	E7	RH Humidity sensor error
AdF	Back up battery alarm		

### 3.5.6 Error display

- ❖ When the upper room cabinet temperature probe has a short circuit failure, the upper room displays "AS1S". When the upper room cabinet temperature probe has an open circuit failure, the upper room displays "AS1b". When the lower room cabinet temperature probe has a short circuit failure, the lower room displays "Ad1S" When the lower room cabinet temperature When the probe has an



open circuit fault, the upper room will display "Ad1b"

- ❖ After the power is switched off, the control function of the controller fails, and the back-up source is used for displaying. If the back-up source is charged for more than 10 hours, the power failure symbol "Pd", the current inside temperature and the alarm display alternatively for one time and then display again after 30s stop for cycle operation. After 8 hours, the Digital screen stops displaying. The power failure alarm light will twinkle continuously until the electric quantity of the back-up source is used up. The inside temperature can be continuously displayed during the power failure. Please pay attention to this and take relevant measures to avoid damage.
- ❖ Advice: Please power off when the temperature sensor is suspected to be broken, check the contact is loosen or not first, then contact after sale service engineer to deal with it.
- ❖  Reminder: Please wait for 1 minute to operate when controller shows parameter code, till the current temperature shows again, to avoid malfunction caused by control parameter changes. When the medical freezer stops temporarily due to power failure or other faults, the inside temperature of the medical freezer will rise. If power cannot be supplied in short time, the user should consider taking out the stored goods and putting them into other normal medical freezers for storing to avoid losses caused by the damage of the stored goods.
- ❖ Before putting goods into the medical freezer to be stored, the user should confirm in advance that whether inside temperature of the medical freezer is in accordance with the set temperature for storing to avoid losses caused by goods damage due to the improper temperature. Due to the refrigeration inertia, the medical freezer cannot be kept at constant temperature. And there is certain up and down difference between the inside temperature and the set temperature. The inside temperature varies with the changing of the environmental conditions and the temperature set. It belongs to normal phenomenon.

## IV. Daily Maintenance

In daily maintenance, in order to prevent electric shock or personnel injuries, be sure to cut off the power before repairing or maintaining the equipment and do not inhale drugs or particulate matters surrounding the equipment when maintaining the equipment. It is necessary to dry wet gloves to protect your hands. Otherwise, your hands may be cut by edges or corners of the freezer body.

### 4.1 Clean of freezer

- Please clean the freezer once a month. Regular cleaning could maintain new outlook of freezer.
- Use dry cloth to wipe off the dust on the housing, or the inner chamber and all accessories of the freezer. If the freezer is very dirty, it is advised to use neutral detergent for cleaning.
- After cleaning, use cloth which has been soaked in clean water to wipe off the detergent.



- Do not pour water on the housing or in the preserve room of the freezer. Otherwise, the electrical insulation may be damaged.
- During the rainy season, defrost may be easily condensed on the surface of the glass door of the freezer. In serious condition, water may drip. Please use dry cloth to wipe it dry in due time. Normal use will not be affected.

## 4.2 Defrost

The freezer belongs to air cooling frost-less freezer which needs no defrosting. In summer with high environment humidity, condensation may appear on the frame of the freezer. This is normal. It is advised to wipe it dry with dry cloth.

## 4.3 Care and Maintenance

- No heavy things are allowed to be placed on the door or the header of the freezer to avoid deformation of the door body or the header caused by the press.
- The freezer should be cleaned and maintained every once in a while.
- Use warm wet soft cloth to wipe the inner and outer surfaces of the freezer.
- When serious dirt appears, use neutral detergent for washing tableware to wipe and then use cleaned soft cloth to wipe out the water spots.
- Keep the freezer running continuously when you power it on.



## V. Troubleshooting

Some abnormal conditions of the freezer are caused by misuse. Please check with the following table before asking for maintenance.

Problems	Reasons and Solving Measures
Not working	<ul style="list-style-type: none"><li>·Whether the power socket has electricity?</li><li>·Whether the power socket is plugged or loosened?</li><li>·Whether the power fuse is disconnected?</li><li>·Whether the supply voltage is too low or too high?</li></ul>
Compressor breaks down	<ul style="list-style-type: none"><li>·Whether the temperature setting is right?</li></ul>



Temperature goes on decreasing. after reaching to the set value	·Whether the temperature setting is right?
Temperature cannot reach the set value	·Whether the fan stops running? ·Whether the door is not closed tight or opened too frequently? ·Whether too many goods are put in at one time and whether the air channel is blocked off? ·Whether the environment temperature is too high?
Too much noise	·Whether the freezer placed at the flat ground? ·Whether the freezer touches the wall? ·Whether the freezer immediately enters operating state after being started?

If you cannot confirm the fault reason or debug, please contact the after-sale service center and tell them your name, address, phone number, freezer model, purchase time, fault phenomenon, etc. Professional engineer will offer warmhearted service to you.





## VI. Main Performance Data

### 6.1 Product Structure and made up.

It is made up with cabinet, door, cooling system, control system and spare parts.

### 6.2 Main Technical Data

Model	Client Type	Inner Temp (°C)	Capacity ( L )	Voltage (V~)	Frequency (Hz)	Exterior Size (W×D×H) mm
YR05293	SN/N	-10~-25	268	220V	50	673×676×1630
YR05294	SN/N	-10~-25	328	220V	50	673×676×1886
YR05097	SN/N	-10~-25	278	220V	50	659×600×1694
YR05306	SN/N	-30~-40	268	220V	50	673×676×1630
YR05307	SN/N	-30~-40	328	220V	50	673×676×1886
YR05308	SN/N	-30~-40	278	220V	50	659×600×1694





### 6.3 Electrical schematic diagram

YR05306/ YR05307

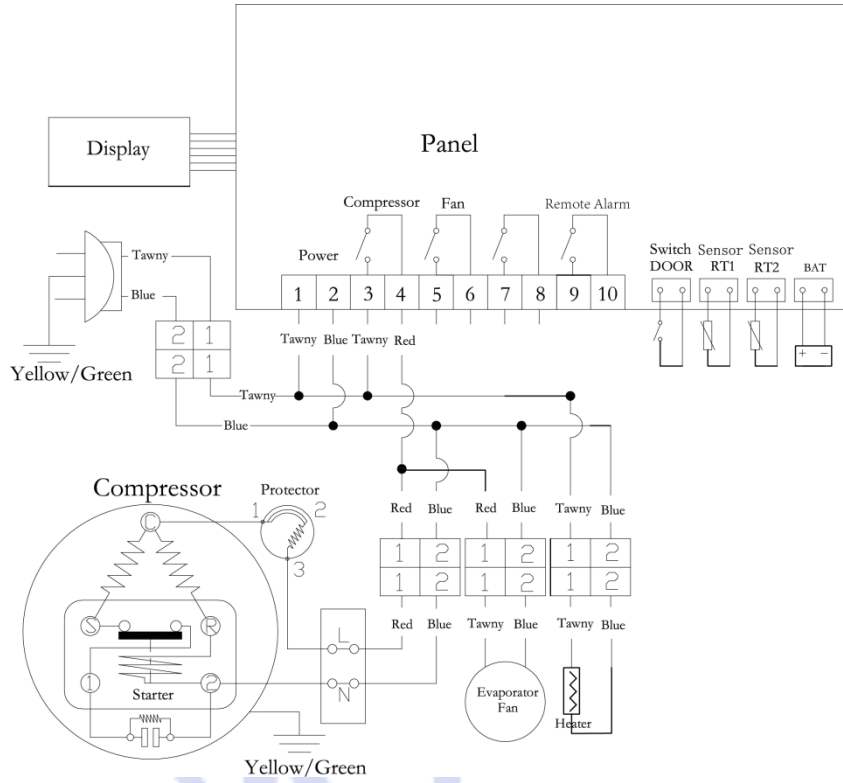

YR05293/ YR05294

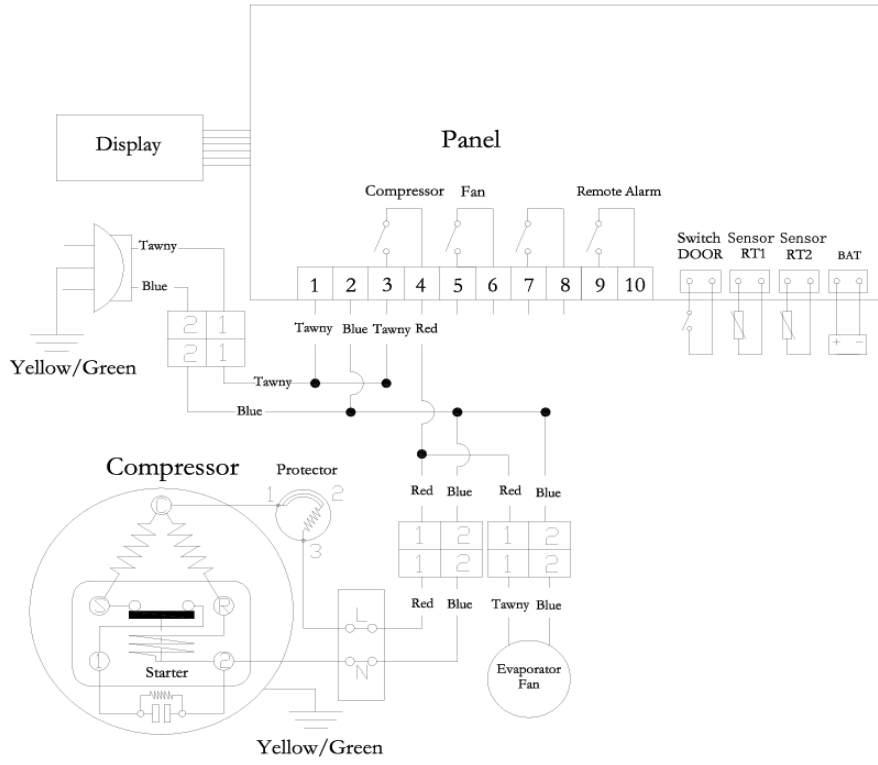

YR05097、YR05308

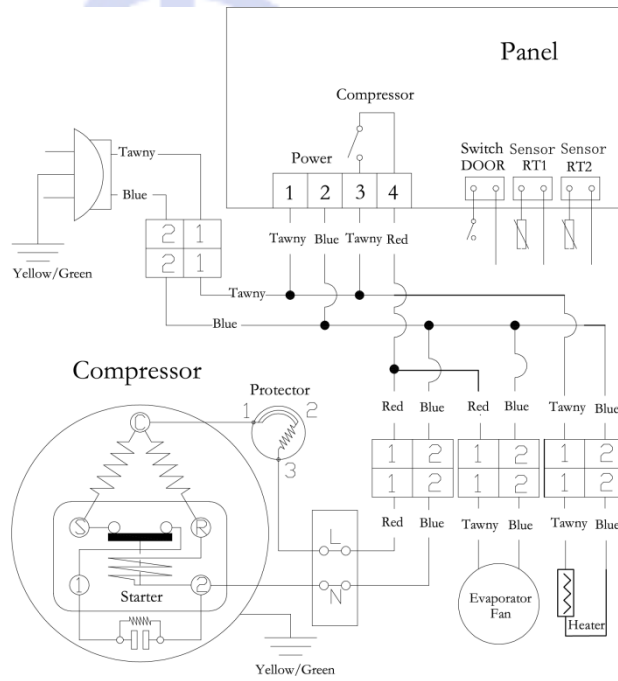

YR05311/YR05310、YR05309/YR05100

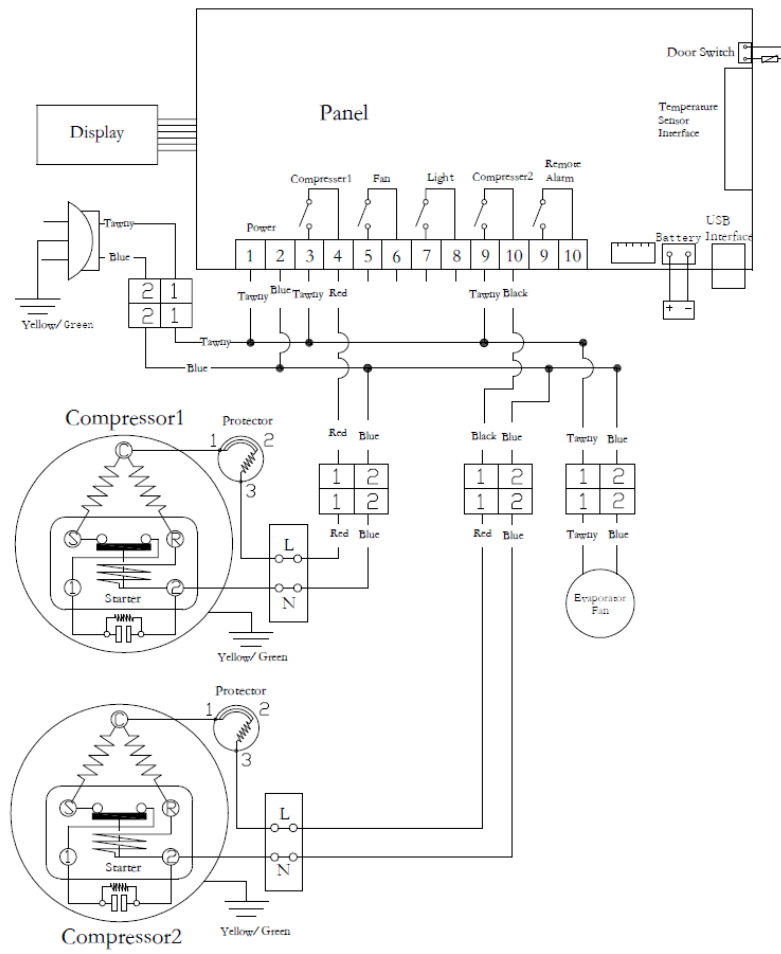

## VII. Packing List

Model	User's manual	keys	Limit parts	Shelves/Drawers	Buckle	Defrost shovel	Plug
YR05293	1	2	2	3	12	1	1
YR05294	1	2	2	4	16	1	1
YR05097	1	2	/	7	/	1	1
YR05311	1	4	2	4/12	/	1	1
YR05098	1	4	2	4/18	/	1	1
YR05306	1	2	2	3	12	1	1
YR05307	1	2	2	4	16	1	1
YR05308	1	2	/	7	/	1	1



Certificate of Quality	
Inspector :	