

Model YR0475
Horizontal Laminar Flow Cabinet
Instruction Manual

Thank you very much for purchasing our Model YR0475 Horizontal Laminar Flow Cabinet.

Please read the “Operating Instructions” and “Warranty” before operating this unit to assure proper operation. After reading these documents, be sure to store them securely together with the “Warranty” at a hand place for future reference.



Warning: Before operating the unit, be sure to read carefully and fully understand important warnings in the operating instructions.



OUR SERVICES

Benefits and Support

In Kalstein France, we take care of the full satisfaction of our customers, that is why we provide value-added services of the highest level based on our experience.



Online Inductions and Trainings

In any part of the world, receive your induction or training from our specialized team of engineers



Quick Response

Our work team is always available to response all your consults or questions, in order to support you in any situation.



#Letsgivemore

Thanks to your purchase, a donation will be made to a non-profit foundation that fights against breast cancer and helps most vulnerable communities.



Technical Support

Enjoy of personalized advice for the correct preventive and corrective maintenance of your equipment, thanks to Kalstein's manuals and articles, special catalogues and video tutorials.



Delivery Logistics

We take care of all the necessary logistics for the dispatch of your goods, whether is by sea, land or air.



Kalstein Worldwide

With more than 25 years growing with our customers, Kalstein's multiformat and modern content, is now present in more than 10 countries and increasing.



Content

Preface	1
Content.....	2
1. Scope of Application.....	4
2. Technical parameters.....	4
3. Performance	5
3.1 Vibration Amplitude.....	5
3.2 Illuminance.....	5
3.3 Electrical Safety	5
4. Product features	5
4.1 Structure.....	5
5. Structure composition	6
5.1 Air Filtration System.....	6
5.2 UV Light Source.....	6
5.3 Lighting source	7
5.4 Waterproof socket	7
5.5 Control Panel.....	7
5.6 Fuse.....	10
6. Installation and Operation Instructions	10
6.1 Installation	10
6.2 Operation Instructions	12
6.3 Contraindication	13
6.4 Operation Conditions	13
7. Maintenance and Common Failure Analysis	13
7.1 Cabinet Surface Cleaning.....	13
7.1.1 Operation area cleaning	13
7.1.2 External surface and side window glass cleaning	13
7.2 Comprehensive Maintenance Interval	13
7.3 Maintenance Method.....	13



7.3.1 Daily or weekly maintenance.....	13
7.3.2 Monthly maintenance.....	13
7.3.3 Annual maintenance.....	14
7.4 Disinfection Method	14
7.5 Common Failures Analysis.....	14
7.5.1 Common failures analysis.....	14
7.5.2 Simple accessory replacement	15
7.6 Storage Conditions.....	18
7.7 Transport Conditions.....	18
8. Precautions.....	18
9. Label Description.....	19
10. Electromagnetic compatibility.....	20
11. Warranty	20
Appendix A Wiring Diagram.....	21
Appendix B Packing List	22



1. Scope of Application

The cleanliness of the Laminar Flow Cabinet operating area can reach ISO 5 level, which is suitable for units and departments that require a local clean working environment such as medical and health laboratories and medical science laboratories. The specific applicable environment is as follows: Working environment:

- (1) For indoor use only;
- (2) Ambient temperature: 15°C ~ 35°C;
- (3) Relative humidity: ≤ 75%;
- (4) Atmospheric pressure range: 70 kPa ~ 106 kPa.

2. Technical parameters

The product is a horizontal laminar flow cabinet. The basic technical parameters are as follows:

Model	YR0475	YR0476	YR0478
Technical parameters			
Outer size (mm)	1100×808×169	1500×808×1690	1800×808×1890
Internal size (mm)	1000×500×600	1400×500×600	1700×500×800
Rated voltage	220V±10% <input type="checkbox"/> 110V±10% <input type="checkbox"/>		
Rated frequency	50 Hz <input type="checkbox"/> 60Hz <input type="checkbox"/>		
Rated power	1200 W	1300W	1400 W
Airflow velocity	59.06-98.43fpm		
UV lamp power	18W	30W	18W*2
LED lamp power	12W	16W	16W*2
Filter efficiency	99.999% (for diameter of 0.3μm)		
Noise	≤65dB (A)		
Power supply	AC 220V 50Hz		
Motor power	90W	180W	270W
Motor speed	1370rpm		
Filter specification	1020×630×69	1420×630×69 (mm)	1720×830×69 (mm)
Service life	8 years		

Note:

- (1) The power consumption of the power supply includes the power of the operating area load (the load cannot exceed 500W);
- (2) The company reserves the right to change the design of the product. The product is subject to



change without prior notice.

3. Performance

3.1 Vibration Amplitude

The air velocity of the laminar flow cabinet should be within the range of 0.30m/s~0.45m/s and the frequency within the range of 10Hz~ 10kHz, the net vibration amplitude should not exceed 5 μm (rms).

3.2 Illuminance

The air velocity of the laminar flow cabinet is within the range of 0.30m/s~0.45m/s, and the average illuminance should not be less than 300lx.

3.3 Electrical Safety

The protective connection impedance of the plug connection equipment: the impedance between the protective conductor terminal and each accessible part that is specified to be connected by the protection is $\leq 0.1\Omega$.
Dielectric strength test: In the AC1390V/50Hz state, test for 5s. After the dielectric strength test, there should be no breakdown or repeated arcing.

4. Product features

4.1 Structure

- (1) The cabinet of the laminar flow cabinet is made of 1.0 mm thick cold-rolled steel plate and the surface is electrostatically sprayed, which enhances the structural strength and makes the entire device more stable; Among them, the operating area is made of 304 stainless steel, which is beautiful and corrosion-resistant; the control panel adopts the touch button mode, the overall appearance is beautiful and the operation is convenient;
- (2) The base is mainly divided into the left side bracket, the right side bracket, the T-shaped frame and the cross brace, which are mainly welded by metal rectangular tubes and electrostatic sprayed on the surface.

5. Structure composition

The laminar flow cabinet are mainly composed of cabinets, fans, high-efficiency filters, Fuma casters, lighting lamps, UV lamp control systems and bases, as shown in Figure 1.

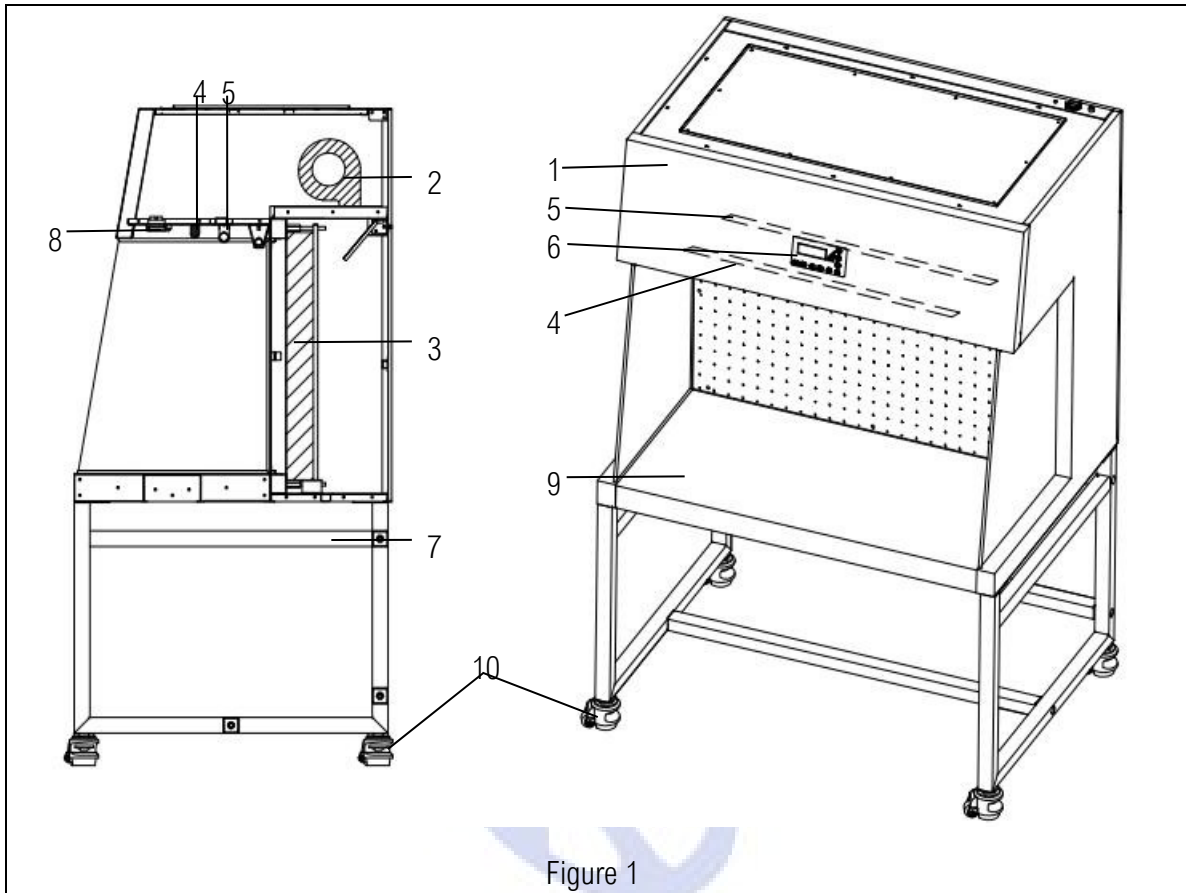

Figure 1

1	Cabinet	6	Display
2	Fan	7	Base
3	High efficiency filter	8	Socket
4	Lighting lamp	9	Working bench
5	UV lamp	10	Fuma casters

5.1 Air Filtration System

The air filtration system is the core system to ensure the best performance of the laminar flow cabinet. It is mainly composed of a fan and an air filter. Its main function is to continuously send clean air into the operation area, ensure the airflow speed in the operation area, and make the cleanliness of the operation area meet the standard requirements.

5.2 UV Light Source

The UV lamp is located inside the operation area to ensure that the ultraviolet light can fully illuminate every place in the operation area, so that the operation area is fully disinfected.

5.3 Lighting source

The lighting source adopts LED lights, which can ensure that the average illuminance in the operating area meets the standard requirements.

5.4 Waterproof socket

A waterproof socket (IP44) is installed in the operating area, which can supply power to the equipment in the operating area.

Note:

- 1) The total power of the equipment used on the two sockets does not exceed 500W (rated voltage*rated current 220V*2.3A);
- 2) The waterproof socket can only be waterproof when the front cover is down. When the front cover is opened, the socket cannot be regarded as a waterproof socket;
- 3) IP44 is the socket protection level. According to the provisions of GB4208: prevent fixed foreign objects with a diameter greater than 1.0mm from entering the socket shell to contact internal parts; prevent splashing water from all directions from entering the socket and causing damage to it.

5.5 Control Panel

Please refer to Figure 2 for the specific use of the control panel.

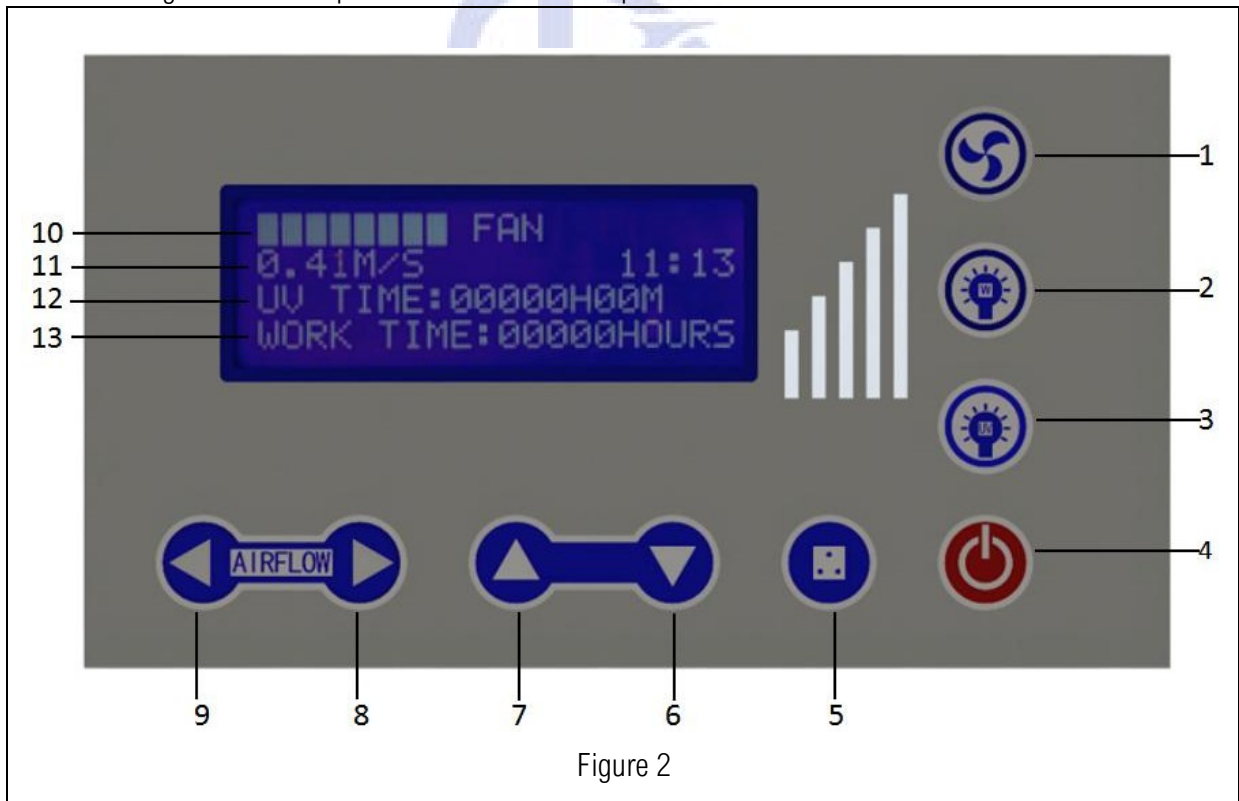



Figure 2

1	Fan button	8	Air flow decrease button
2	Lighting lamp button	9	Air flow increase button
3	UV lamp button	10	The gear change of wind speed when the fan is working
4	Power button	11	Actual wind speed and time under current fan gear

5	Socket button	12	Cumulative working time of UV lamp
6、7	Function setting debugging button	13	Cumulative use time of high efficiency filter





a. Gear display



Through the gear display  , you can understand the wind speed gear situation when the laminar flow cabinet is working.

b. Touch the button

The operation of the laminar flow cabinet needs to be realized by tapping the buttons. Please refer to Table 2 for the details of the tapping buttons.

Table 2. Detailed description of the touch button

	Power button	The main switch that controls other function button
	Fan button	It is the control key for the working status of the fan. Each time you press it, the working status of the fan and the corresponding indication status on the LCD display will change once (this key is only valid when the current window glass is open).
	Lighting button	Each time you press, the state of the lighting tube changes once, that is, from off to bright, and from bright to off.
	UV lamp button	Control button for UV lamp. Each time you press it, the status of the UV lamp and the corresponding indication status on the LCD display will change once, either from bright to off, or from off to bright (this key is valid only when the current window glass is completely
	Socket button	The control key of the socket on and off the working state. Each time you press, the on-off status and the corresponding indication status on the LCD display will change once.

	<p>Function setting debugging button</p>	<p>Use this button when debugging and setting related functions.</p>
	<p>Air flow adjustment button</p>	<p>Users can adjust the wind speed according to actual operation needs.</p>

c. Please refer to Table 3 for specific function setting instructions.

Table 3. Function setting detailed description table

Control panel related function settings	Setting method
<p>Clock adjustment</p>	<p>In the standby state, press and hold the bright button to alarm once to enter the clock setting state. At this time, the hour digit starts to flash, press the wind speed button to adjust the clock size, Then press the fan button. At this time, the minute digit starts to flash, continue to press the wind speed button to adjust the minute digit. When the minute and hour digits are adjusted to the current time, press the bright button to alarm again to save the clock settings.</p>
<p>UV lamp timing adjustment</p>	<p>Turn on the UV lamp button and turn on the UV lamp. Use the wind speed increase button or the wind speed decrease button to adjust the size of the UV lamp timing time, which can be adjusted within 0-90min; When there is an appointment timing state, the display screen will show *; when there is no appointment timing state, the display screen does not show *.</p>
<p>UV lamp and fan appointment timing switch</p>	<p>In the standby state, long press the No. 7 button in Figure 2 to enter the timing interface. Press the fan key in the timing interface to perform the shift operation (the digit that needs to be set at this time enters the flashing state); Then press the fan speed up and down buttons to set the corresponding time. In addition, press the socket button to switch between the UV lamp and the fan. In the scheduled timer state, press and hold the bright button to reset to zero to cancel the timer function. (Note: The fan and UV lamp cannot be reserved at the same time)</p>
<p>Pressure unit conversion</p>	<p>Turn on the fan button, and press and hold the UV button for 5 seconds to switch between Pa and m/s.</p>

UV lamp and fan, lighting lamp, interlock	When the lighting lamp and fan are turned on, the UV lamp cannot be turned on
--	---

5.6 Fuse

The laminar flow cabinet is equipped with a power fuse, which is located on the side of the power cord outlet on the side of the box. For the corresponding specifications and models of the fuse, please refer to the section 9. Label description.

6. Installation and Operation Instructions

6.1 Installation

- a. Remove all packaging components.
- b. Check whether there are scratches, deformations or foreign objects on the outer surface of the host.
- c. Check the relevant accessories and information carefully according to the packing list of the accessories in the manual.
- d. Move the equipment near the final placement point and facilitate the installation position, prepare the S8 Allen wrench that needs to be used, and then proceed with the installation operation.

Note:

The base part is placed at the back of the laminar flow cabinet during transportation, and it should be taken out before installation; it is strictly prohibited to move the laminar flow cabinet with the bottom facing upwards, and it is strictly forbidden to place or disassemble it.

- e. Assembly of base part

Before assembling the base, please unscrew the M10*55 hexagon socket head bolts in the cross brace and T-bracket. For the specific assembly process of the base, please refer to the installation diagram of the base, as shown in Figure 3.

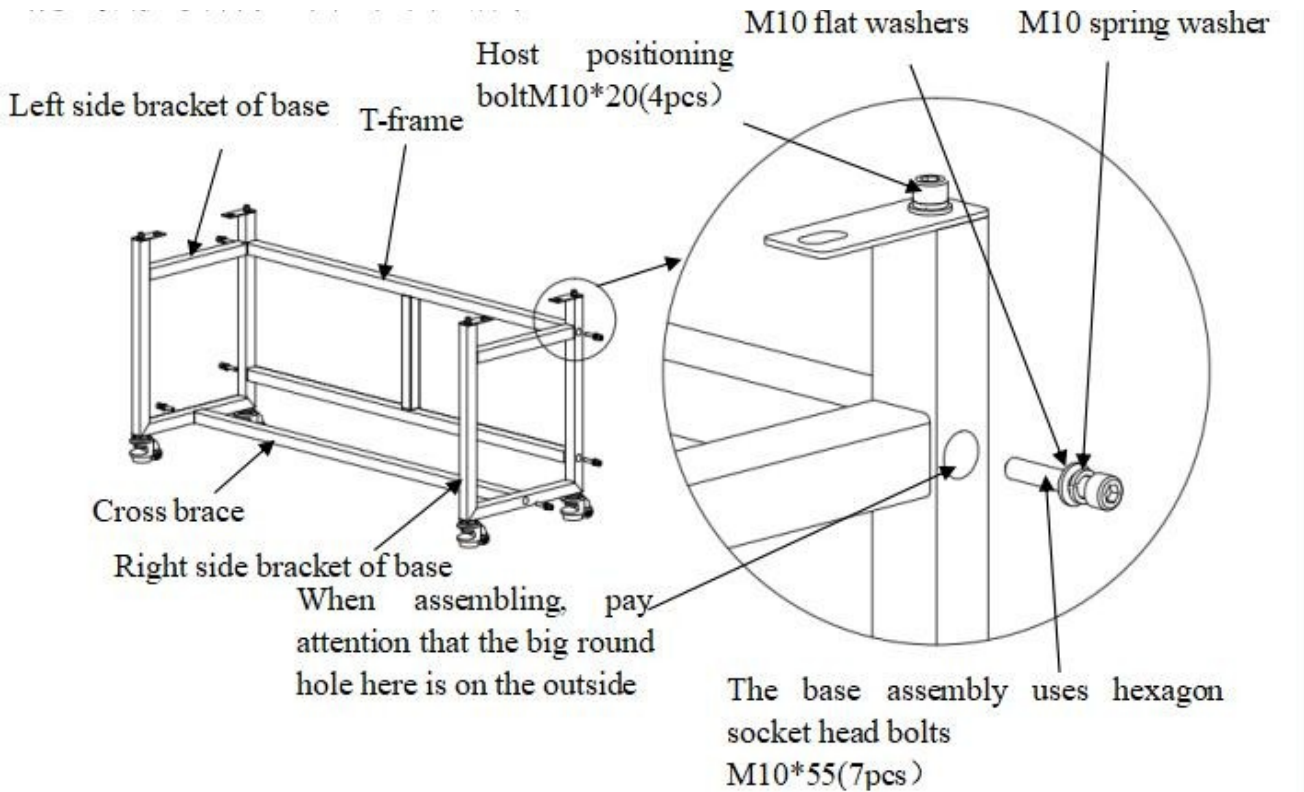

Figure 3

f. Adjustment of Footmaster Caster

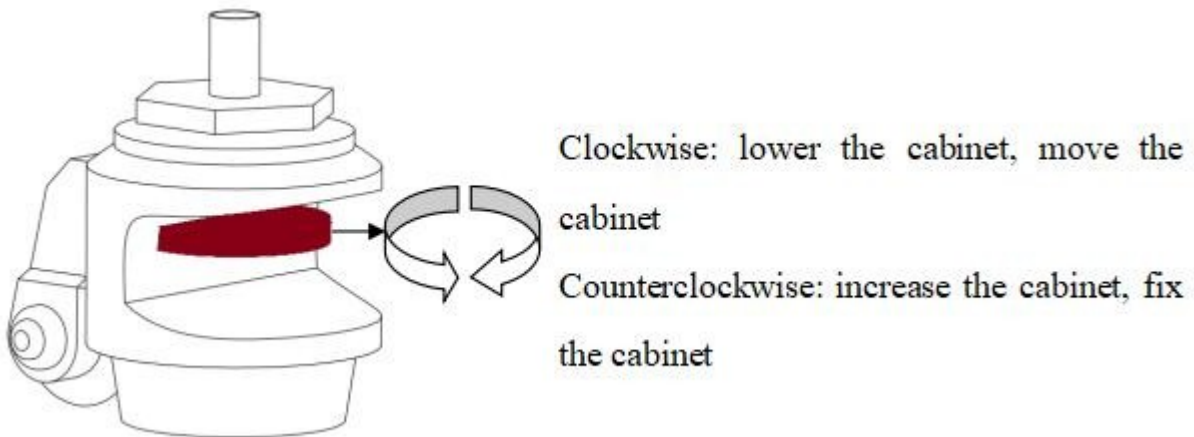
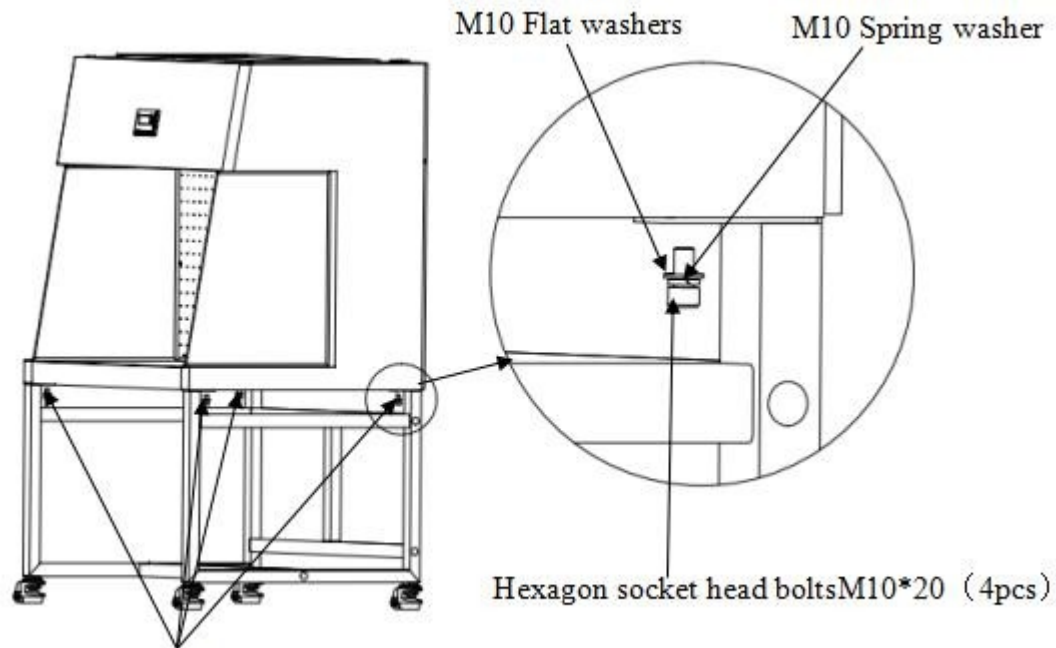

Figure 4

Please refer to Figure 4. Rotate the red part of the Fuma casters clockwise to lower the corresponding base feet, thereby reducing the height of the cabinet. When the four Fuma casters are lowered at the same time, the cabinet can be moved; Rotate the red part of the Fuma casters counterclockwise to raise the corresponding base feet to increase the height of the cabinet. When the four Fuma casters are raised at the same time, the cabinet can be fixed; The simultaneous adjustment of four Fuma casters can make the cabinet in a horizontal and stable state.

g. The host is connected to the base

Please refer to Figure 5 for the connection between the host and the base. To connect the host to the base, M10*20 hexagon socket head bolts, flat washers 10, and spring washers 10 need to pass through the base from the bottom up to the host side plate to fix the host and the base firmly.



Use bolts to connect the base and the host

Figure 5

h. Placement of the equipment

The laminar flow cabinet should be placed in a relatively stable indoor airflow area to reduce the impact of environmental factors such as ventilation system, air conditioning, doors, windows, and personnel movement on the performance of the clean workbench; It is forbidden to place the laminar flow cabinet in a location that is difficult to cut off, and at least 300mm of space must be reserved on each side of the laminar flow cabinet for subsequent inspection and maintenance.

Note:

- (1) The cabinet body should be installed in a larger and open place;
- (2) When moving the cabinet, it is necessary to cut off the power supply and adjust the Fumacasters before moving slowly;

6.2 Operation Instructions

- a. Connect the power supply;
- b. Press the relevant function key (refer to the description in 5.6 for relevant keys, functions and operations);
- c. Before use, turn on the UV lamp and disinfect for more than half an hour; Note:
 - (1) When disinfecting, people should leave the room to protect the eyes and skin of the operator and avoid damage to the skin and eyes of the operator due to accidental exposure;
 - (2) The intensity of the UV tube should be tested regularly according to the manufacturer's specifications. It is recommended to be done once a quarter. If it fails, it needs to be replaced.
- d. Before use, turn on the fan and run it for half an hour before performing normal experimental operations in the operating area of the laminar flow cabinet;

Note: In order to ensure the safety of the experimental operation, please place the experimental supplies in the operating area of the laminar flow cabinet in advance.

- e. After use, turn on the UV lamp, disinfect for more than half an hour, and then turn off the clean

bench.

6.3 Contraindication

None.

6.4 Operation Conditions

The laminar flow cabinet can protect the sample during use, but not the operator and the environment, so the operator needs to wear protective clothing, masks and medical rubber gloves for personal protection during the operation.

7. Maintenance and Common Failure Analysis

Since it is necessary to arrange when to perform maintenance according to the specific usage of the laminar flow cabinet, we recommend that when using the laminar flow cabinet, a detailed record sheet of the operation time of the laminar flow cabinet should be prepared for reference and inquiries.

7.1 Cabinet Surface Cleaning

7.1.1 Operation area cleaning

Wipe the entire surface of the operation area with a soft cotton cloth soaked in concentrated soap solution, then wipe the soap foam with another cotton cloth or towel soaked in clean hot water or warm water, and finally dry quickly with a dry cloth or towel; When the 304 stainless steel work surface is contaminated or has traces, it can be wiped with medical alcohol.

Note: The disinfectant used should not damage 304 stainless steel.

7.1.2 External surface and side window glass cleaning

You can choose any non-abrasive household cleaner, and wipe the outer surface of the laminar flow cabinet and the side window glass with a soft cotton cloth or towel.

7.2 Comprehensive Maintenance Interval

It is recommended that the overall maintenance period is one year or 1000 working hours.

7.3 Maintenance Method

7.3.1 Daily or weekly maintenance

- a. Disinfection and cleaning of the operating area (refer to 7.1.1 instructions);
- b. Clean the external surface around the operating area, side window glass, etc. (refer to 7.1.2 instructions);
- c. Check the various functions of the laminar flow cabinet to see if the corresponding working status is abnormal;
- d. Record this maintenance result.

7.3.2 Monthly maintenance

- a. External surface cleaning (refer to 7.1.2 instructions);
- b. Wipe the laminar flow cabinet surface, the inner surface of the operation area (without the uniform wind net of the operation area), and the inner surface of the side window glass with medical alcohol, and finally need to wipe it again with sterile water.
- c. Check the various functions of the laminar flow cabinet to see if the corresponding working status

is abnormal;

d. Record this maintenance result.

7.3.3 Annual maintenance

- a. Check the UV tube and lighting tube, and it is forbidden to wipe the lamp body with a wet cloth when the power is on;
- b. Apply for the inspection of the overall performance of the laminar flow cabinet every year to ensure the performance of the laminar flow cabinet, and the user will pay for the inspection fee;
- c. Record this maintenance result.

7.4 Disinfection Method

For specific disinfection methods, please refer to the disinfection procedures recommended in Appendix B of "YY0569-2011 Class II Biological Safety Cabinet".

7.5 Common Failures Analysis

7.5.1 Common failures analysis

Before diagnosing the fault, please confirm whether the power supply is well connected, whether the power cord is obviously damaged, whether the fuse is in good contact, and whether the switch is turned on. After excluding the above specific conditions, please refer to the troubleshooting table 4 for further troubleshooting.

Table 4. Troubleshooting table

Fault	Checking parts	Method
The LED light doesn't light up or is abnormal	Light tube	Replace the lamp
	Line	Check the line
	Control board	Replace the control board
UV lamp doesn't turn on or is abnormal	Interlock	Confirm whether the fan and lighting lamp are off
	Lamp holder	Check whether the lamp tube and the lamp holder are firmly connected
	Lamp tube	Replace the lamp
	Ballast	Replace the ballast
	Line	Check the line
	Control board	Replace the control board
Buttons don't work	Control board	Confirm that the power supply is connected and energized, and the fuse is not damaged
		Make sure the buttons are not damaged
		Make sure that the connection line is not in bad contact

		Replace the control board
The device is not powered	Power supply	Power is not connected
	Power cord	Check whether the power cord is obviously damaged
	Fuse	Check whether the fuse is in good contact
	Transformer	Check whether the transformer output is normal
	Control board	Replace the control board
The display does not lightup	Connection cable	Check whether the connection cable is in good contact
	Display	Check whether the display is good
	Control board	Replace the control board

Note:

- (1) The operation of the above electrical parts must be carried out by a professional electrician under safe conditions (it is forbidden to replace any parts of the clean bench when the power is on), If the laminar flow cabinet cannot be used normally due to disassembly of electrical components, the consequences shall be borne by the person who disassembles the parts; and the parts of the laminar flow cabinet except for electrical appliances are not allowed to be disassembled, otherwise the consequences shall be borne by the user;
- (2) When the laminar flow cabinet has a failure other than the above, and the operator cannot eliminate it immediately, please notify the after-sales department of our company immediately. For your safety, please do not repair it yourself;
- (3) The maintenance work of the laminar flow cabinet requires professional and technical personnel to perform maintenance;
- (4) If you need to order parts, you can go through our technical service department. Please inform our technicians that the model and number of the laminar flow cabinet you purchased (can be obtained from the laminar flow cabinet nameplate).

7.5.2 Simple accessory replacement**1) Replace the fuse**

The socket fuse ($\Phi 5 \times 20$ (5A)) is located at the top of the right side plate of the clean bench. When replacing, first turn off the power and unplug the plug. Use a Phillips screwdriver to press and screw the fuse holder counterclockwise, remove the fuse in the fuse holder and replace with a new fuse, and then press and screw the fuse holder clockwise; The live wire fuse ($\Phi 5 \times 20$ (10A)) is located on the side of the socket fuse. Use a flat-blade screwdriver to lift out the fuse holder, replace it with a new fuse, and then press it back. Please refer to Figure 6.

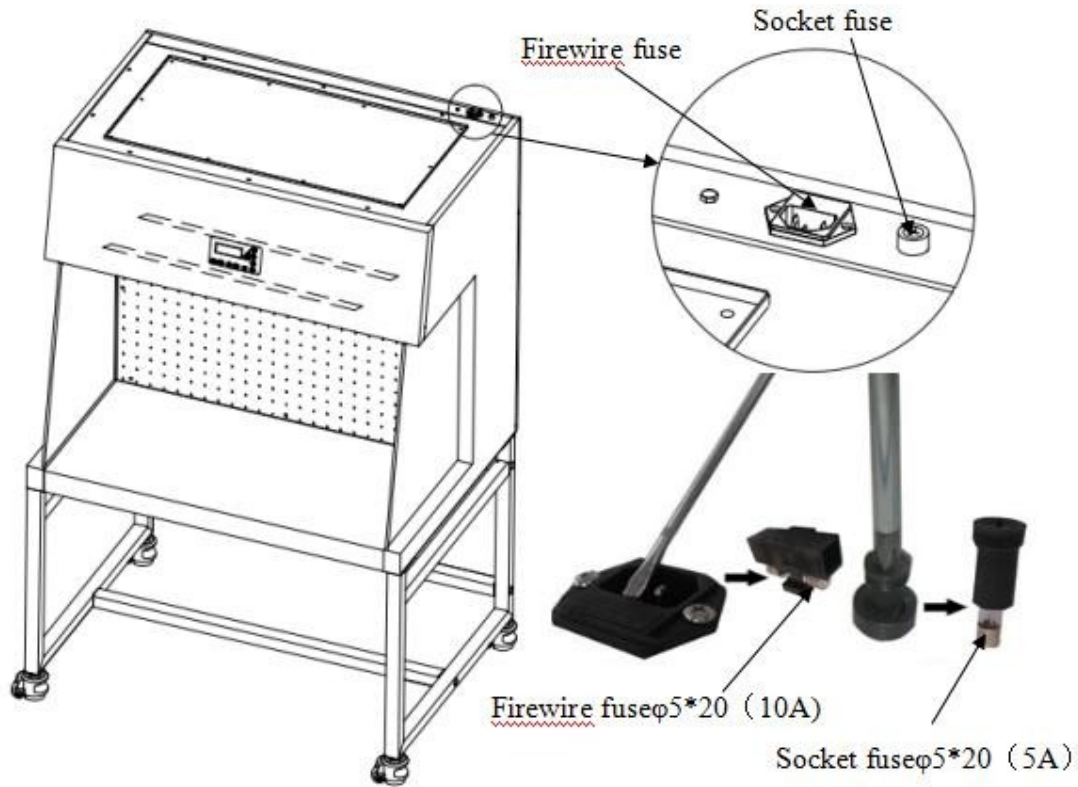

Figure 6

2) Replace the UV lamp

The service life of the UV disinfection lamp equipped with the laminar flow cabinet is 600 hours of cumulative working time. In order to achieve a good disinfection effect, it is recommended that you regularly test the UV intensity. You can use the UV intensity test card to confirm whether the UV lamp needs to be replaced. When replacing, first disconnect the power of the laminar flow cabinet, and then turn the UV lamp clockwise or counterclockwise 90° to remove it. Take an ultraviolet lamp of the same specification, push it into the lamp holder and turn it clockwise or counterclockwise by 90° so that the pins at both ends of the ultraviolet lamp are perpendicular to the plane of the lamp holder to complete the installation. Please refer to Figure 7 for specific operations.

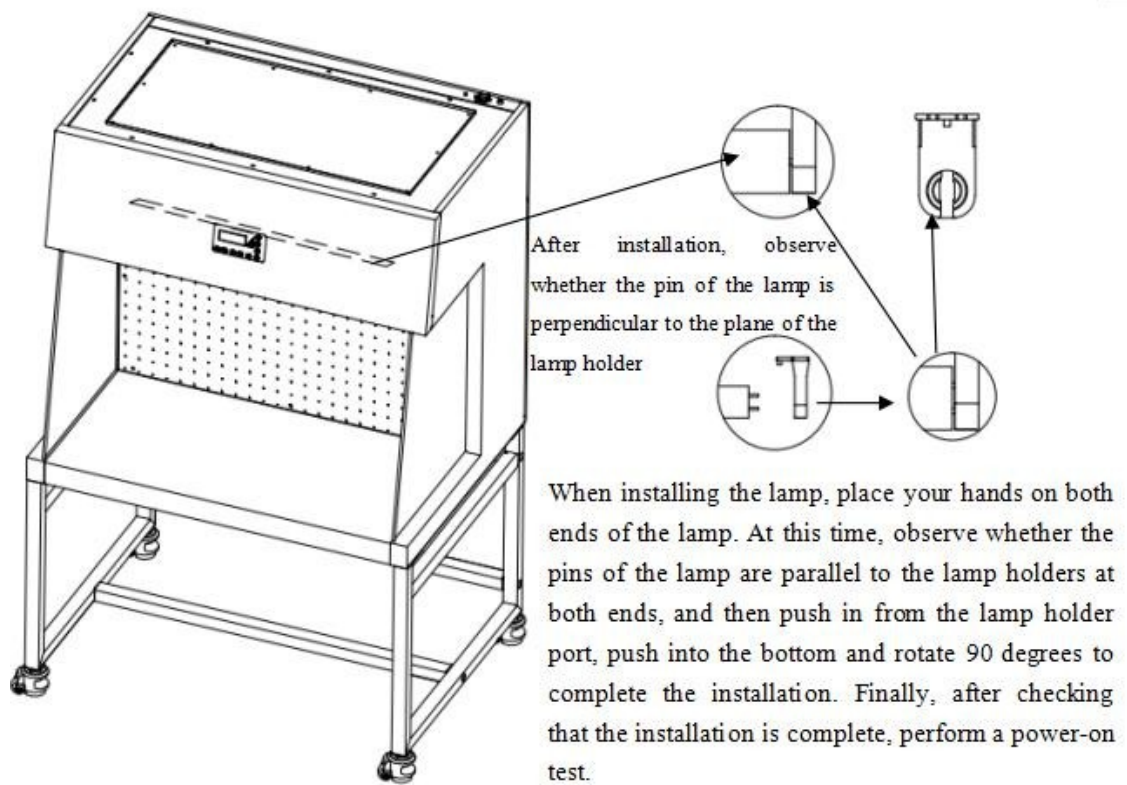

Figure 7

3) Replace the lighting lamp

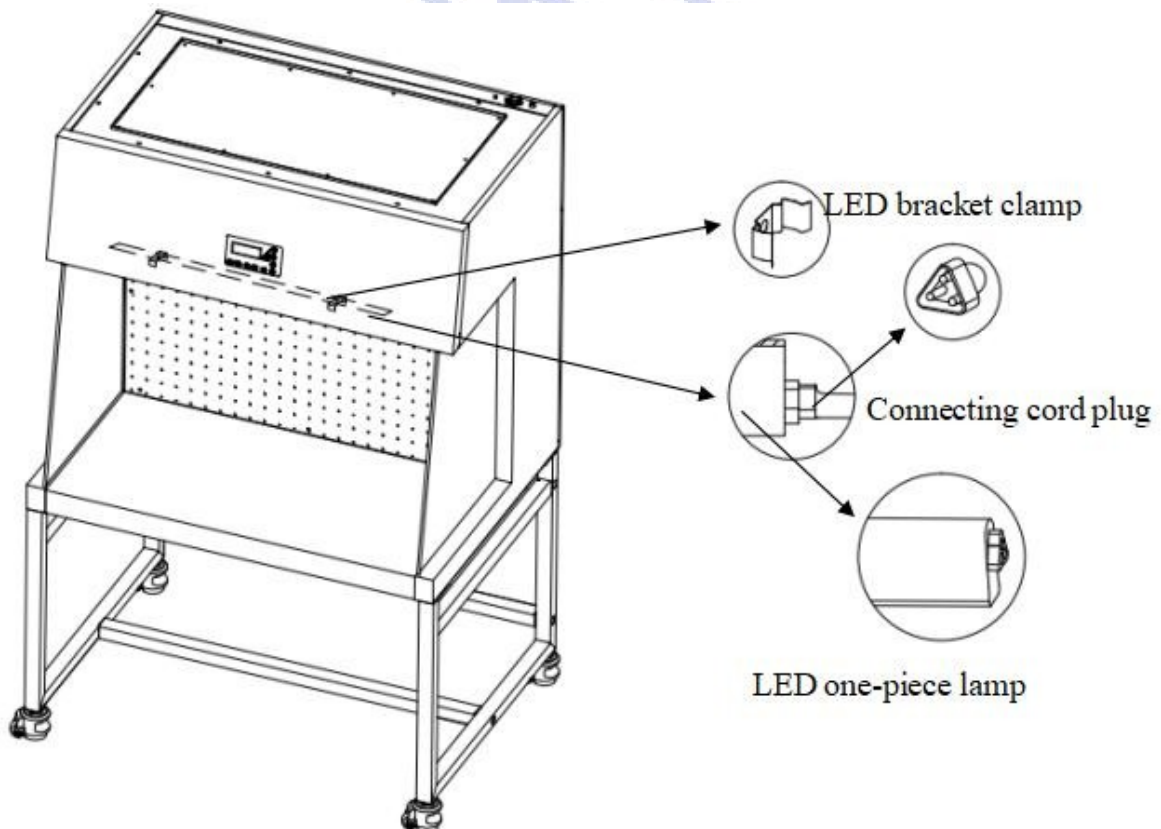

Figure 8

When the laminar flow cabinet lighting needs to be replaced, disconnect its power supply, Then take off the LED integrated bracket obliquely, unplug the right cable plug, replace with a new LED bracket, and then tilt it into the LED card slot head. Please refer to Figure 8 for details.

7.6 Storage Conditions

The laminar flow cabinet is stored in a warehouse where the relative humidity does not exceed 75%, the temperature is lower than 40 °C , and the ventilation performance is good, and there is nocorrosive gas such as acid and alkali. The storage period should not exceed one year. Laminar flow cabinets that exceed one year need to be unpacked for inspection. After the unpacking inspection is qualified, the laminar flow cabinets can enter the circulation field.

7.7 Transport Conditions

Corresponding measures should be taken in accordance with the requirements of the external surface of the packaging box during the transportation of the laminar flow cabinet. The buyer should carefully check the integrity of the packing box when receiving the laminar flow cabinet with packing box sent by the logistics company. If the packing box is damaged or squeezed, please refuse to sign for it, and contact our company in time.

Note: When the clean workbench that has been installed and used is moved or moved again, please contact our company in time.

8. Precautions

- (1) Before connecting the AC power supply, make sure that the power supply voltage is consistent with the input voltage of the laminar flow cabinet and the voltage is stable, and the rated load of the power socket is not less than the requirement; in order to ensure the safety of electricity, the laminar flow cabinet uses a grounding plug, The plug has a grounding pin and can only be used with a grounded power socket. If the plug cannot be inserted into the socket, you should ask a professional electrician to install a grounded power socket, and make sure that the grounding is good before use.
- (2) The weight of items placed on the laminar flow cabinet should not exceed 23Kg/25×25cm².
- (3) To avoid vibration, try to avoid the use of vibrating instruments (such as centrifuges, vortex oscillators, etc.) in the operating area of the laminar flow cabinet, because vibration may damage the glass; At the same time, the particulate matter accumulated on the filter membrane may be shaken off, resulting in a decrease in the cleanliness of the operating area; strong vibration may cause unstable performance of the laminar flow cabinet and affect its use.
- (4) It is forbidden to use open flames in the laminar flow cabinet! The use of an open flame will cause turbulence in the operation area and damage the filter; at the same time, high temperature disinfection and sterilization are required during the experiment. It is strongly recommended to use an infrared sterilizer.
- (5) As the service life of the high-efficiency filter is extended, the accumulation of dust and bacteria in the filter will cause the filtration efficiency of the high-efficiency filter to be reduced, and the cleanliness of the operating area cannot meet the requirements. You must contact the service department of our company in time and replace the high-efficiency filter, otherwise it will affect the safe use of the laminar flow cabinet. The replaced high-efficiency filter must be treated as medical waste.
- (6) Fans and high-efficiency filters are mainly used to achieve strict sealing treatment through fan

battens. During the use of laminar flow cabinet, they must strictly maintain their sealing properties. The operator must not loosen or disassemble the bolts of these components. If you have special needs, you must contact our company's service personnel for processing.

(7) The storage period of the laminar flow cabinet is one year. Products that exceed the storage period must be inspected once by our company's technicians and can be used only after being qualified.





Serious declaration: If the laminar flow cabinet is not used according to the method specified by our company, the protection provided by the laminar flow cabinet may be damaged. For the risks caused by the operation not in accordance with the regulations, our company will not bear its responsibility!

9. Label Description

Please refer to Table 5 for the specific usage and precautions of the laminar flow cabinet label.

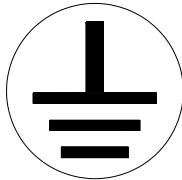
Table 5

<div style="display: flex; justify-content: space-around; align-items: center;"> <div style="border: 1px solid black; padding: 5px; margin: 2px;">F10AL250V</div> <div style="border: 1px solid black; padding: 5px; margin: 2px;">F5AL250V</div> </div>	Fuse label (10A power fuse label/5A socket fuse label)
	Lighting lamp anti-shock label
	Ground label
	UV lamp warning label
<div style="border: 1px solid black; padding: 10px;">  <p>Maximum power 500W</p> <p>Please use a well-grounded electrical appliance</p> </div>	The load requirement label (the total load power of the two sockets cannot exceed 500W) In all cases marked with this symbol, the document needs to be consulted in order to clarify the nature of the potential hazard and any countermeasures that must be taken.

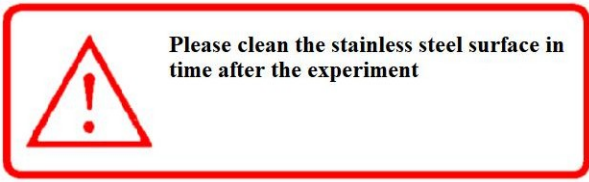
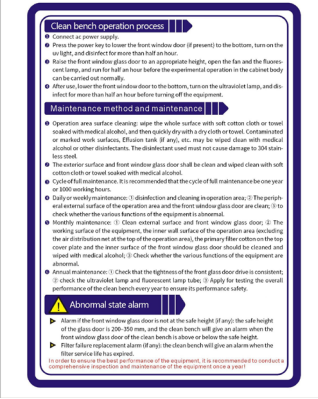
	<p>Stainless steel warning label</p>
	<p>Laminar flow cabinet SOP label</p>

10. Electromagnetic compatibility

- 10.1 This laminar flow cabinet meets the emission and immunity requirements specified in GB/T 18268.1-2010.
- 10.2 The laminar flow cabinet is designed and tested according to Class A equipment in GB 4824. In the home environment, it may cause radio interference, and protective measures need to be taken.
- 10.3 It is recommended to evaluate the electromagnetic environment of the laminar flow cabinet before use. It is forbidden to use the laminar flow cabinet near strong radiation sources (such as unshielded radio frequency sources), otherwise it may interfere with the normal operation of the equipment.

11. Warranty

- 11.1 The warranty period is 12 months from the date of purchase (excluding lamps and fuses (fusetubes)).
- 11.2 If the instrument and equipment during the warranty period become invalid or damaged due to improper use by the user, the company shall not assume the warranty obligation.
- 11.3 After the warranty period, the company is also responsible for repairs, but the corresponding repair fees will be charged.
- 11.4 The service life of the laminar flow cabinet is 8 years, and the production date is shown on the product label.
- 11.5 The maintenance organization and maintenance personnel trained and approved by our company can provide the drawings and some necessary technical data of the laminar flow cabinet.

Appendix B Packing List

YR0475 packing list:

Name	Qty.
YR0475 main unit	1 unit
YR0475 base stand	1 unit
RVV power line	1pc
Fuse (10A)	1pc
Fuse (5A)	1pc
UV lamp (T8 20W)	1pc
YR0475 User Manual	1copy
Testing report	1copy
Certificate of conformity	1copy
Warranty card	1copy
Hexagon socket head bolts M10*20	5pcs
Flat Washer 10+Spring washer 10	5pcs
Allen wrench	1pc
Button plug (white)	7pcs

YR0476 packing list:

Name	Qty.
YR0476 main unit	1 unit
YR0476 base stand	1 unit
RVV power line	1pc
Fuse (10A)	1pc
Fuse (5A)	1pc
UV lamp (T8 30W)	1pc
YR0476 User Manual	1copy
Testing report	1copy
Certificate of conformity	1copy
Warranty card	1copy
Hexagon socket head bolts M10*20	5pcs
Flat Washer 10+Spring washer 10	5pcs
Allen wrench	1pc
Button plug (white)	7pcs

YR0478 packing list:

Name	Qty.
YR0478 main unit	1 unit
YR0478 base stand	1 unit
RVV power line	1pc
Fuse (10A)	1pc
Fuse (5A)	1pc
UV lamp (T8 20W)	1pc
YR0478 User Manual	1copy
Testing report	1copy
Certificate of conformity	1copy
Warranty card	1copy
Hexagon socket head bolts M10*20	5pcs
Flat Washer 10+Spring washer 10	5pcs
Allen wrench	1pc
Button plug (white)	7pcs

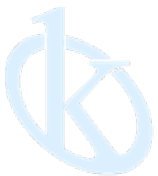

All rights reserved © KALSTEIN France S. A. S.,
2 Rue Jean Lantier • 75001 Paris •
+33 1 78 95 87 89 / +33 6 80 76 07 10 •
<https://kalstein.eu>
KALSTEIN FRANCE, S. A. S