



Heating Incubator (LCD)

Model YR02050

Instruction Manual

Thank you very much for purchasing our Kalstein's Heating Incubator (LCD) Model YR02050

Please read the "Operating Instructions" and "Warranty" before operating this unit to assure proper operation. After reading these documents, be sure to store them securely together with the "Warranty" at a hand place for future reference.



Warning: Before operating the unit, be sure to read carefully and fully understand important warnings in the operating instructions.



OUR SERVICES

Benefits and Support

In Kalstein France, we take care of the full satisfaction of our customers, that is why we provide value-added services of the highest level based on our experience.



Online Inductions and Trainings

In any part of the world, receive your induction or training from our specialized team of engineers



Quick Response

Our work team is always available to response all your consults or questions, in order to support you in any situation.



#Letsgivemore

Thanks to your purchase, a donation will be made to a non-profit foundation that fights against breast cancer and helps most vulnerable communities.



Technical Support

Enjoy of personalized advice for the correct preventive and corrective maintenance of your equipment, thanks to Kalstein's manuals and articles, special catalogues and video tutorials.



Delivery Logistics

We take care of all the necessary logistics for the dispatch of your goods, whether is by sea, land or air.



Kalstein Worldwide

With more than 25 years growing with our customers, Kalstein's multiformat and modern content, is now present in more than 10 countries and increasing.





1. Application

YR series heating incubator is a constant temp. equipment. Widely used in biological chemistry, chemical pharmacy, medical institution, industrial and mining enterprises, university and colleges, scientific research, etc. can be used for seed, cell, bacteria culture, etc.

2. Working principle

Heating incubator transfers actual temperature detected from temperature sensor into signal, through microcomputer control to heater towards required temperature.

3. features

- 1.The shell is made of steel plate, and outside surface is spray paint treatment.
2. Handle and controller are integrated, humanity design, easy to operate.
- 3.The inner chamber is made of stainless steel , heating way is air jacket type. heating wiring are evenly distributed around the inner chamber , and there is fan for air circulation to make sure uniform temperature.
- 4.Arc-design, easy to clean.
- 5.Adjustable shelf board.
- 6.The thermal insulation material is glass fiber. double-doors, magnetic silicone door seal, easy to operate and make sure good sealability .
- 7.YR heating incubator is a equipment with PID control, highly precise and advanced .
- 8.LCD display, with timing function, and the unit of timing is hour or minute.



9.If need timing function, you can stop heating output or keep present temperature after timing is over . beeper beeps after timing is over.

4.Product structure

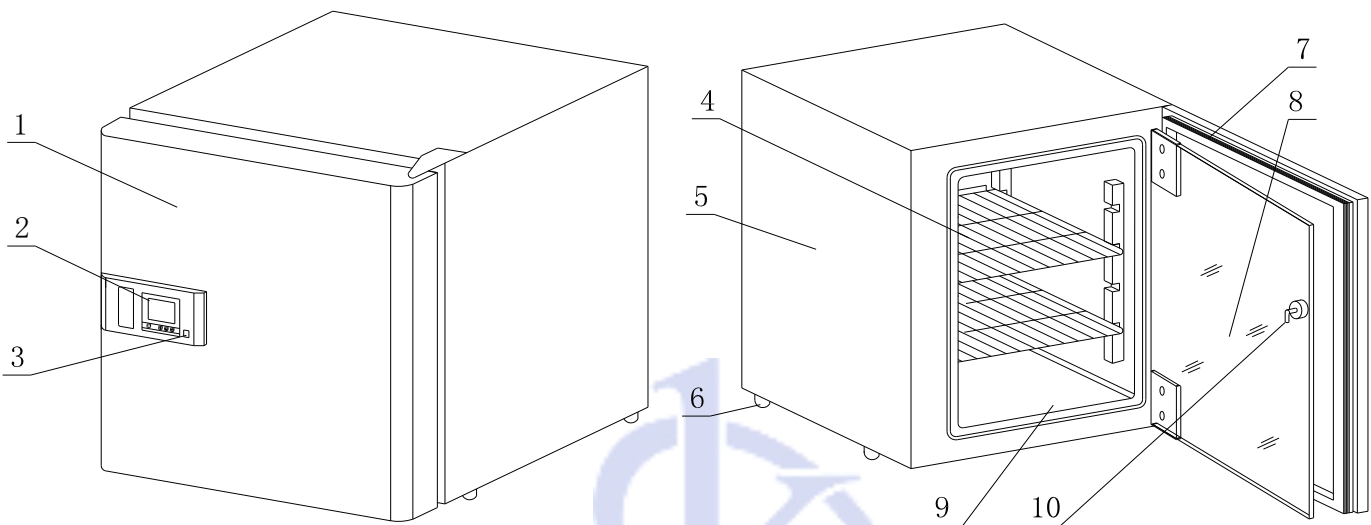

- | | | | |
|-------------------|------------------|----------------------|----------|
| 1. outer door | 2. handle | 3. power | 4. shelf |
| 5. incubator body | 6.rubber feet | 7 magnetic door seal | |
| 8.glass door | 9. inner chamber | 10.hook | |

5. Operation

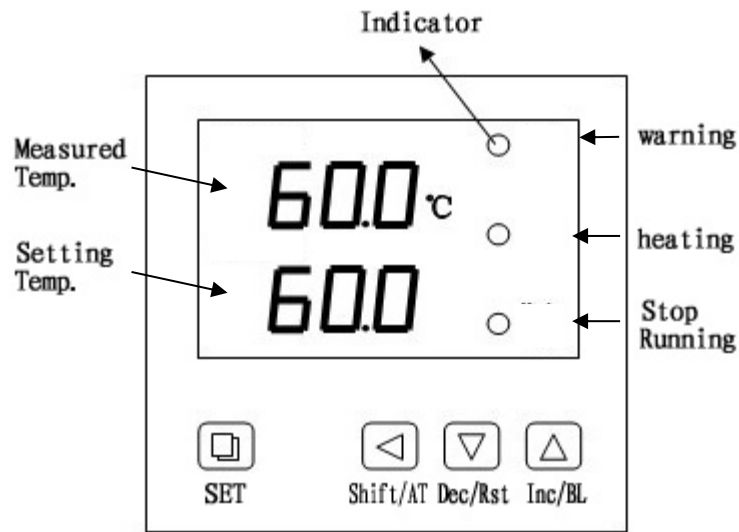

Key function

1. "set" button: set or view temperature, time and other settings.
2. "◀" shift/ auto-setting" button: in non-setting mode, long press this button for 6 sec. to enter or exit auto-setting; in setting mode, press this button to modify set value.
3. "▼"decrease/rerun" button: in non-setting mode, when run finishes, long press this button for 3 sec. to rerun; in setting mode, press this button to decrease set value, long press this button to decrease continuously
4. "▲"increase/backlight" button: in non-setting mode, press this button to turn on or off the screen backlight; in setting mode, press this button to increase set value, long press this button to increase continuously.

6.Parameters

- 1、 Temp control range : RT+5~65°C;



- 2、 Temp. resolution: 0.1°C
- 3、 Temp fluctuation range : $\pm 0.5^{\circ}\text{C}$ ($+5^{\circ}\text{C}\sim 50^{\circ}\text{C}$);
- 4、 Temp uniform range : $\pm 1.0^{\circ}\text{C}$ ($+5^{\circ}\text{C}\sim 50^{\circ}\text{C}$);
- 5、 Power voltage : AC 220V/50Hz;
- 6、 Timing range: 0~99hour, 0~9999min
- 7、 Equipment class: class I
- 8、 Working ambient : ambient temp 10~40°C relative humidity 70% below ;

7. Installation

In order to optimize the performance of equipment, please install the equipment in the following condition:

 Attention: ambient temperature 10~30°C ;relative humidity less than 70%

1. Avoid exposure to the sunlight.

Do not place it in direct sunlight, or it won't reach predicted performance

2. An efficient ventilative place

If you operate this equipment in a narrow and concealed room, it may lead to over-heating and malfunctioning. Minimum safe distance between equipment and wall is

10CM

1. Keep away from heat source

Don't install the equipment near heating source. External excess heat will affect performance of the equipment and may cause malfunctioning

2. Flat and firm ground

Make sure to install it in flat and firm ground. Uneven surface or leaning installation may damage equipment or injure people. Proper installation can avoid shaking and noise

3. Avoid humid place

Install the equipment in a place where humidity is less than 70%. Otherwise it may cause creepage or electric shock.

 **Warning**

Do not place this equipment outdoors. If it exposed in the rain, it may cause creepage and electric shock.

Do not place equipment in humid environment or a place with dripping water. Otherwise it may cause creepage or electric shock

Otherwise it may cause explosion or fire. Do not place equipment in the place where has acidic and corrosive gas, or corrosion will cause creepage, electric shock or equipment damage.

Installation

1. Unpacking

Remove packing materials, open the door for ventilation. Please use neutral detergent to clean if the shell and panel is dirty. Then wipe with wet cloth and at last with dry clean cloth

2. Level equipment

Fix equipment with the front brake-wheel after installation in case equipment moves.

To prevent shaking on uneven ground, pads maybe needed.

3. Protective conductor thermal

 **Warning**

Please use power socket that has protective conductor terminal in case of electric shock. If it is not connected, has to install protective conductor terminal by licensed technician.

Do not connect protective conductor terminal through gas, water pipe, telephone line or lighting arrester which will cause electric shock.

4. Idle equipment

Before setting equipment aside, empty water in the humidifier and remove internal moisture thoroughly. Be sure the inner chamber is dry and cool before closing the door .

5. Moving equipment

Before moving equipment, empty inner chamber to prevent objects falling off.

Preparation before hand

When equipment is running the first time, please operate according to following:

- Take out the shelf boards and other accessories inside.
- Clean the inner chamber with gauze
- Insert the shelf boards into inner chamber according to your experiment and requirement
- If you place samples on the same shelf, should keep space between samples for air circulation.

 **Attention : Do not use NaCl or other Halide solution to clean this equipment, or it will cause rust**

8.Operation

1. Start the equipment, screen display will light up. Wait for 3 seconds to enter the starter mode.
2. view and set temperature and timing time

1) if no timing function

Press “set” key, enter temperature setting mode, the upper screen displays “ SP” , the lower screen displays setting temperature, modify setting value through shift, increase, decrease key , re-press “set” key to log out setting mode, the modified value will be saved automatically .

2) if with timing function

Press “set” key, enter temperature setting mode, the upper screen displays “Sp” and the lower displays setting temperature, modify setting value through shift, increase, decrease key , re-press “set” key to enter timing mode, the upper screen displays “ST”, the lower screen displays timing time; re-press “set” key to log out setting mode, the modified value will be saved automatically .

When timing time is “0”, means no timing function, ,controller will run continuously, the lower screen displays setting temperature; then timing time is not “0” , the lower screen displays running time or setting temperature, when displays “running time” , after test temperature reaches setting temperature, timer starts timing, “running time” flashing, when time is up, running stops, the lower screen displays “End” beeper beeps, it will stop beeping one minute later. After running is over, long press “ decrease “ key for 3 minutes to reboot it

Notice : if increase setting temperature during timing, it will re-time from “0” , if decrease setting temperature during timing, it will keep timing

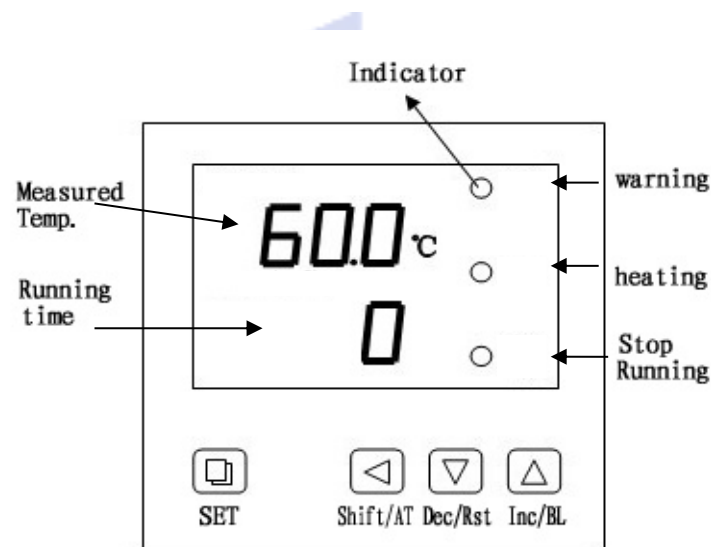

3. temperature sensor, if the upper screen displays“---“ ,it means that there is something wrong with temperature sensor or temperature is outside of measure range or controller fails, controller will cut off heating output automatically, and with continuous beep, alarm indicator is on, please check temperature and connection.



4. When over-temperature alarming, beeper beeps , alarm indicator is on; when lower-temperature alarming, beeper beeps, alarm indicator flashing; if the over-temperature alarm because of the change of setting temperature , alarm indicator is on, but no beep
5. beeper keep beeping, press any key to mute
6. Controller will return back to normal mode without pressing any key within one minute

(2). Auto-setting

If the temperature control is not ideal enough to meet your requirement , please proceed with auto-setting . temperature will soar during auto-setting, please take this factor into consideration before proceed with it

In non-setting mode, long press “shift/auto-setting” for 6 seconds to access auto-setting system, auto-setting flashing, it will stop flashing if auto-setting is over, controller will gain a new PID parameters, and parameters will be saved automatically. You can stop auto-setting during auto-setting via long press “shift/auto-setting” key

If it occurs over-temperature alarm during auto-setting, alarm indicator is out , no beep, but the relay of heating alarm will cut off itself . “set” key is unavailable during auto-setting. No matter there is setting for timing, then lower screen always displays setting temperature.

9. view and set intrinsic parameter

Long press “set” key for 3 seconds, the upper screen displays “Lc” and the lower screen displays password, please modify required password through decrease, increase and shift key.



Re-press “set” key, if the password is incorrect, controller will return back to normal mode automatically; if the password is correct, it will access setting mode of intrinsic parameter.

Re-press “set” key to modify other parameters. Long press “set” key to log out

intrinsic parameter -1

Parameter code	Parameter name	Function instruction	(range) factory default
Lc-	Password	“Lc=3”view and modify parameter	0
ALH-	Over-temp. alarm	when “test temp. > set temp. +AL ”, alarm light is on, alarm beeps, stop heating.	(0~100.0°C) 20.0
ALL-	Lower-temp. Alarm	when“test temp.<set temp.+ALL”, alarm light is flashing, beeper beeps	(0~100.0°C) 0
T-	Control cycle	heating control cycle	(1~60sec.) 5
P-	Proportion	timing proportion adjustment.	(1 ~ mileage value)
I-	Integral time	integral acting in regulation	(1~1000sec.) 380
d-	Differential time	differential acting in regulation	(0~1000sec.) 280
Pb-	Zero adjustment	Modify error margins of sensor(low temp.) during test. Pb=actual temp.- test temp.	(-12.0~12.0°C) 0.0
PK-	Full-scale adjustment	Modify error margins of sensor(high temp.) test. PK=1000*(actual temp.- test temp.)/test temp	(-999~999) 0

Notice :PCD-D3000C (relay output) controller, the factory default is 20 seconds , other models is 5 seconds

intrinsic parameter-2

Parameter code	Parameter name	Function instruction	(range) factory default
Lc-	Password	“Lc=9”View and modify parameters	0



ndA-	Temperature alarm way	0: only alarm when over-temperature 1: alarm when over-temperature and lower-temperature as well	(0~1) 0
Hn-	Timing way	0: minute; 1:hour	(0~1) 0
EH-	Whether need constant temp. control after timing is over	0: Cut off heating output after timing is over 1: Need constant temp. control after timing is over	(0~1) 0
oPn-	Door control function	0: Turn off the function of door-open judgment 1: Turn on the function of door-open judgment	(0~1) 0
nP-	Max power output	The max power percentage of heating output	(0~100%) 100
Co-	turn off heating output	When "test temp. \geq setting temp.+ Co", cut off heating output	(0~100.0) 0.3
SPL-	Min setting temp.	Min setting temp.	(-50.0~0) 0
SPH-	Max setting temp.	Max setting temp.	(0~400.0) 60.0
Addr	Communication Address	Communication Address of this equipment	(1~32) 1

10. Assistant Configuration Connection

Notice : in order to make sure good communication, please use Shielded Twisted Pair

(STP) communication data line (such as power line and load line)

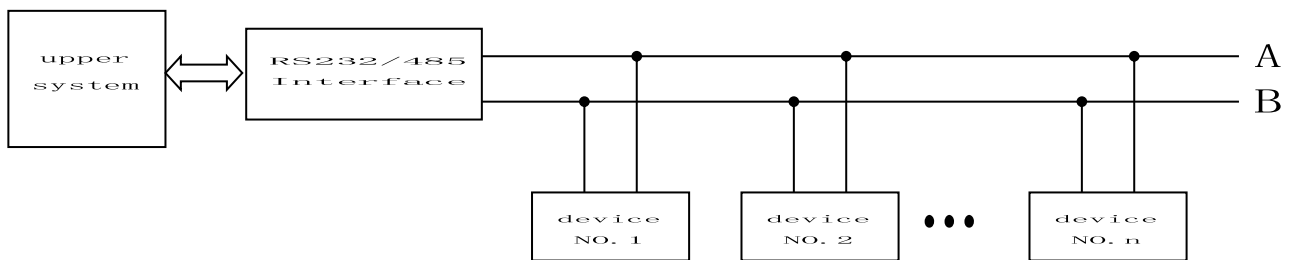

Alarm and safety functions

- **Temperature sensor failure alarm:** Screen displays: “- - -”, that is temp. sensor or controller failure.
- **Temperature limit alarm:** when test temp. is beyond 20 degrees, heating stops, “ALM” alarm indicator light is on. Alarm keeps beeping. Press any button to mute.



11.Routine using and maintenance

⊘	Do not capsize when moving.
⊘	Do not change the settings frequently during process, it may affect the life of use
!	The machine is equipped with power switch and circuit breaker, if failure occurs during operation, please cut off the power and check the control circuit if it's intact, and then check the other parts. (See wiring diagram)
!	Make sure the door is shut. If the door is not closed properly, the device may not be able to reach maximum performance. do not slam the door to avoid damage of the locking system.
!	Do not use corrosive solution to wipe the exterior in order to maintain the appearance of equipment. Please use dry cloth or alcohol to wipe inner chamber
!	If set the equipment aside, keep inner chamber dry, and cut off the power supply.
!	In order to keep temperature uniform inside the chamber, check the axial fan in the chamber if it is functioning properly. During the experiment, in order to allow air circulation, samples should not be placed too crowded .Do not touch and collide temperature sensor,or it may cause failure of temperature control.
!	Fix shelf. Otherwise it may damage the samples .
⊘	Do not lean against the glass or apply pressure on the glass, it might cause injury.
⊘	Do not lean against the door of the device. To prevent tipping of the equipments or equipment damage, personal injury by the damaged door.
!	When failure occurs, please arrange professionals or contact with the factory sales department. User should not attempt to repair or fix it.
!	Our company products have “Three Guarantees” from the date of original purchase. one year warranty, free to repair (exclude mis-operation and consumable items) when equipment has failure

11.Trouble shooting

Trouble	handling
Sensor failure display (- - -)	Temperature sensor is abnormal, please check temperature sensor (model:PT100)
Temp. can't reach setting value	Check screen if it is heating, If yes, then heating wiring is damaged or control panel failure or circuit failure.



Temp. rises too slow	Check fan whether is working properly (Open the door). If it's not running, check according to the wiring layout
Screen can not display	·Please check if the power socket is ~220V ·Please check if the power switch is on ·Please check power switch, if it is tripping operation, please check wiring layout.

12.Specification

Name	YR Heating Incubator		
Model	YR02050	YR02051	YR02052
Interior Dimension	580×530×600	680×630×600	800×750×700
exterior Dimension	380×380×350	480×480×350	600×600×450
Volume	50L	80L	160L
Power	450W	450W	650W
Shell	Cold-roll steel sheets with spray paint treatment		
Inner chamber	stainless steel		
Door	adopt thermal insulation material		
Heating insulation system	Polystyrene foam		
Temp. control system	PID auto-setting;		
Heating system	Heating wiring		
Fan	Centrifugal fan		
Temp. sensor	Sum sung Temp. sensor PT100		
Screen	LCD displayer		
Weight	33.5Kg	40.5Kg	52Kg
Shelf	2		
Optional Accessories	Switch port ,Portable printer,		



Notice : without notice if there any change of design and specification

13.Wiring layout

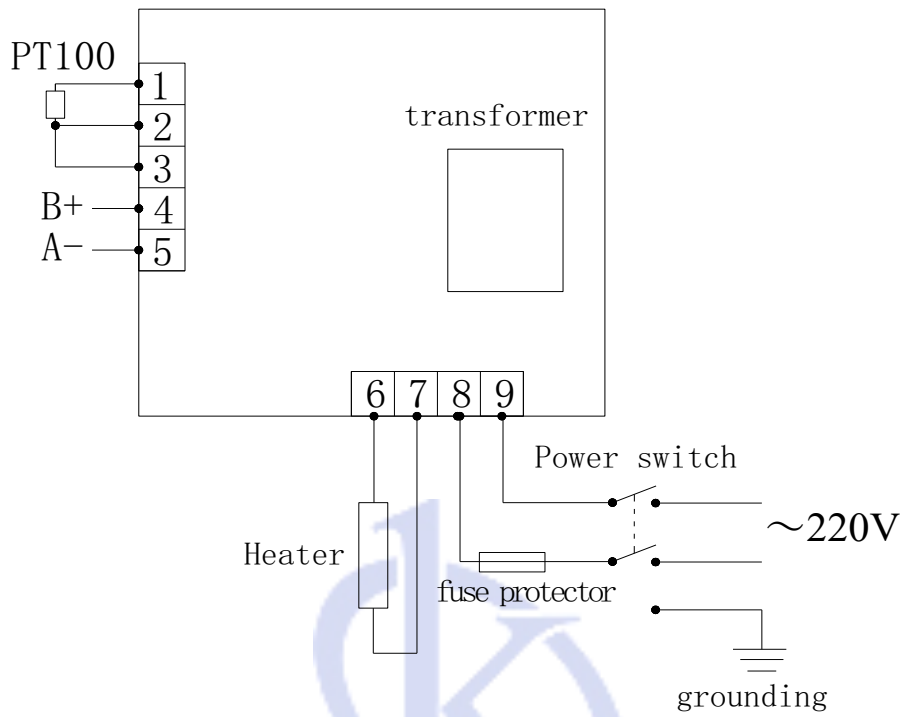

Heating Incubator

Packing list

No.	Name	Quantity	Note
1	Equipment	1	
2	User manual	1	
3	Shelf	1	