



4.3 inch TFT Lab Sonicator

Model YR05017

Instruction Manual

Thank you very much for purchasing our Kalstein's 4.3 inch TFT Lab Sonicator Model YR05017.

Please read the "Operating Instructions" and "Warranty" before operating this unit to assure proper operation. After reading these documents, be sure to store them securely together with the "Warranty" at a hand place for future reference.



Warning: Before operating the unit, be sure to read carefully and fully understand important warnings in the operating instructions.



OUR SERVICES

Benefits and Support

In Kalstein France, we take care of the full satisfaction of our customers, that is why we provide value-added services of the highest level based on our experience.



Online Inductions and Trainings

In any part of the world, receive your induction or training from our specialized team of engineers



Quick Response

Our work team is always available to response all your consults or questions, in order to support you in any situation.



#Letsgivemore

Thanks to your purchase, a donation will be made to a non-profit foundation that fights against breast cancer and helps most vulnerable communities.



Technical Support

Enjoy of personalized advice for the correct preventive and corrective maintenance of your equipment, thanks to Kalstein's manuals and articles, special catalogues and video tutorials.



Delivery Logistics

We take care of all the necessary logistics for the dispatch of your goods, whether is by sea, land or air.



Kalstein Worldwide

With more than 25 years growing with our customers, Kalstein's multifomat and modern content, is now present in more than 10 countries and increasing.





Contents

Chapter 1 Introduction.....	1
1.1 General Description	1
1.2 Functions and Composition	1
Chapter 2 Diagram	7





Chapter 1 Introduction

1.1 General Description

4.3 inch TFT touch screen series ultrasonic homogenizer Sonicator is our company's new developed product. With full functions, beautiful appearance, reliable performance. Instrument using large LCD display screen, using the central computer centralized control system, ultrasonic output, gap time, ultrasonic power, duty cycle, and temperature can be arbitrarily set, sample detection temperature display, frequency automatic tracking, automatic fault alarm.

1.2 Functions and Composition

2.1 Our ultrasonic homogenizer sonicator is a multi-function and multi-purpose instrument that utilizes ultrasonic cavitation in liquid. It can be used for breaking many kinds of cells, bacteria, viruses, animal and plant tissues, also for emulsification and separation, homogenization, extraction, deforming, cleaning, preparation of nanomaterial's, dispersion and accelerated chemical reactions. Widely used in biology, medicine, agriculture, chemistry, materials science, pharmaceutical and other fields of teaching, research, production.

2.2 This machine consists of ultrasonic generator (power), transducer components and sound proof box, middle part connected by the cable

1.3 Functions and Composition

3.1. **Check power supply:** This machine is powered by $220V \pm 5\%$ AC voltage (frequency 50Hz), the power socket is located in the lower left of the instrument rear panel. Please pay attention to the color of the power supply are fitted at the left lower sections of the backboard.

Warning: Please kindly use grounded AC power supply to avoid lightning and for safe using, and remove the plug when replacing the fuse

3.2 Working environment



The instrument should be placed in a well-ventilated place to work, the normal working room temperature range is 0 °C to 40 °C.

In order to ensure that the instrument can work normally, please kindly note: Anti-corrosion, moisture-proof, sun protection, dust prevention

3.3 Installation

- Connect the power cord, transducer and temperature probe according to each socket
- Insert the transducer into the soundproof box and select suitable container according to the sample size, pour the sample and put it on the lifting platform of the sound proof box. Adjust the lift height, the end of the horn inserted into the sample surface is generally 10-20mm and make it in the center of the container.

The horn cannot touch the wall of the container, the end part of horn and the bottom of the container should be more than 4cm (or will case no load when with bigger power), to ensure the good break effect

Recommended for use elongated containers. When process small capacity samples, using small ultrasonic power, the horn never can contact with the bottom of the container.

1.4 Scope of Application for Various Specifications of horns and the power ratio for new instrument as follows:

Horns (mm)	Φ2	Φ3	★Φ6	Φ8	Φ10
Process capacity (ml)	0.1-5	3-10	10-100	20-150	30-300
Power ratio (1-100%)	1-45%	1-55%	1-75%	1-90%	10-95%

1.5 Function and main parameters

- ✓ For the first time use, add water in a 50ml beaker, then put it on the lifting table of the sound proof box, place the transducer on the top hole of the sound proof box, adjust the lift to make the liquid surface immersion horn end face 1-2cm.
- ✓ Connect the power supply, temperature, transducer interface of the ultrasonic generator, turn on the power switch on the back of the instrument.
- ✓ 3.Click the password box after turn on the machine, then type "123456" to enter the factory standby state(usually remove the password before leaving the factory).
- ✓ Please see below diagram "standby interface A"

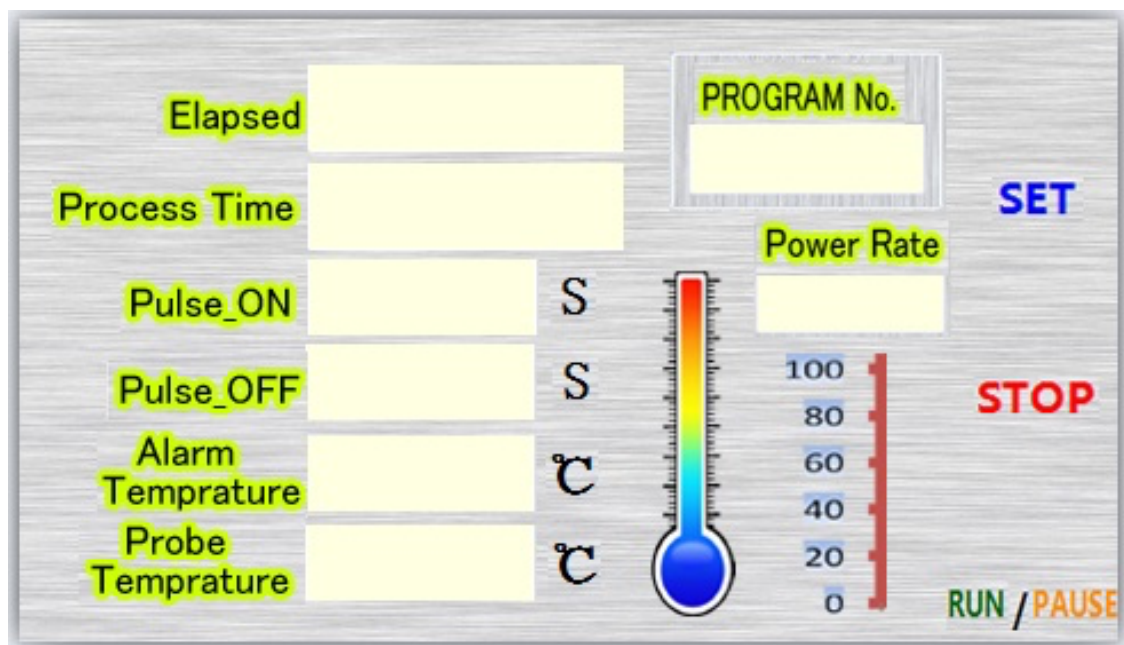

"Standby interface A"

- ✓ Check if the horn size on the screen consistent with the actual one, if need to reset, please click "SET" button, enter the setting state, as shown in the following figure "Setting interface B", at this time can modify the parameters according to your requirement, click on the box to set your needed parameters, modify it when the numeric keypad jump out, usually cannot set "0"

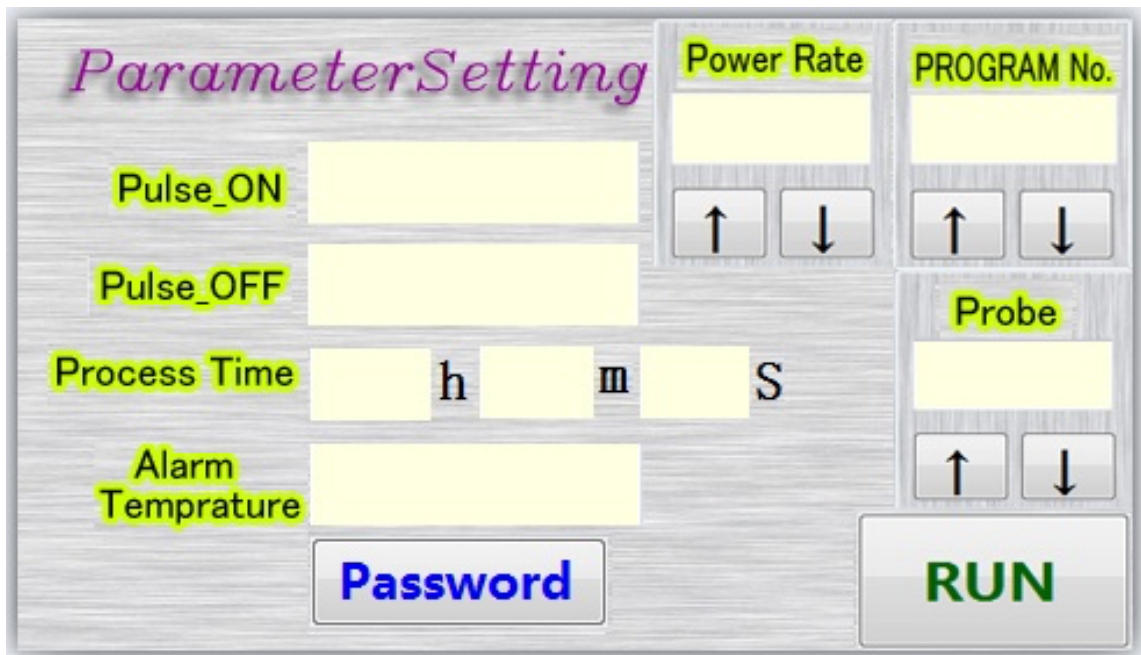

"Setting interface B"

(The choice of horn should consistent with the actual installation horn's size)

- ✓ After setting the parameters and click the "RUN" button, the interface into standby state, then click the "RUN" button again, the instrument begin to work, if need to stop the ultrasound can click the "PAUSE" button, If one cycle of work finished, you need to continue to work, please click "STOP" button, then click "RUN" button, in order to ensure user's experimental data preservation, this instrument has 20 sets of parameters stored (0-19) and call function, adjust above "settings interface B " PROGRAM No." is ok.
- ✓ If the "RESET" key box becomes yellow when the instrument on the working process, it's for over-temperature alarm, please check whether the set temperature is too low, It's for overload or fault alarm if turn into red color, then click the "reset" key box cancel the alarm.

1.7 Main technical parameters of the instrument

Output power	2.5-250W (adjustable)
Working frequency	20-25KHz frequency automatic tracking
Process capacity	0.1-300ml (need to match corresponding probe)
Timing	0-99H59M59S (can be set)
Working mode	Pulsed
Pulse	0.1-99.9s adjustable interval/working)
Temperature control	Control samples' temperature (0°C-100°C)
Alarm	Fault, temperature, time
Input method	touch screen control,
Display method	touch screen control, 4.3 inch TFT
Display content	Temperature, power, time, etc.
Protective device	Program automatic error correction, overload, over temperature protection display
Storing data	20 groups
password	Have user password protection
Standard configuration	Ultrasonic generator (host) one set Sealed transducers + 6MM horn one set
Optional horn	Φ2, Φ3, Φ6, Φ8, Φ10
Power supply (AC)	220V±5% /50Hz

1.8 Instrument interface description (Rear Panel)

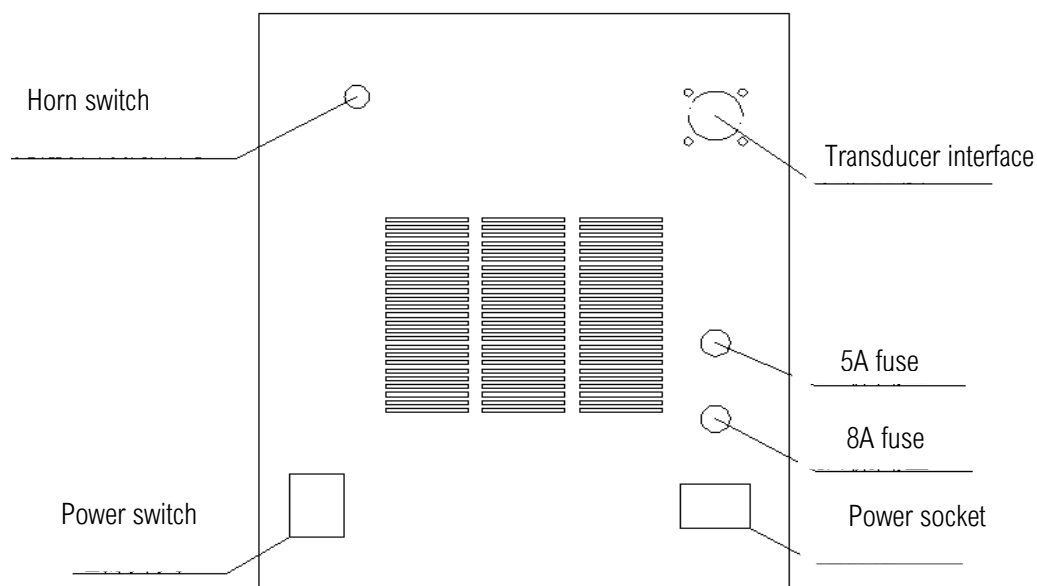



1.9 Instructions

5.1 Cautions

1. Temperature protection set point should be **1-3°C higher** than the room temperature or the sample temperature. Machine will stop in case of over-temperature.
2. **Don't start the machine when the horn is not inserted into the liquid (no load)**, otherwise it will damage the instrument
3. Process capacity, ultrasonic time power, waiting for user explore according to a variety of different cells and select the best value
4. After using a long time, the end of the horn will be cavitation corrosion and hairy, can use oil stone or file make it flat, otherwise will affect the work effect
5. In the working process, due to ultrasonic cavitation in the liquid effect, the liquid temperature will rise rapidly, the user should pay more attention to the temperature of various cells, recommended to use short ultrasonic time (less than 5 seconds each time)

While also can connect cooling bath for cooling (**ultrasonic time 1-3 seconds and gap time 2-6seconds**)

Warning: Turn off the power supply when you change the horn. Please re-select correct horn specification on the interface after restart; otherwise it may cause horn to be damaged

KIND REMIND:

★ Practices prove that instrument will have a better performance at working 1~3 seconds and interval 2~6 seconds. You may set a longer gap time to avoid liquid temperature increase. In addition, continuous working may cause empty load, will shorten the life of the instrument

Φ6mm horn's maximum output power should not exceed 80% for new instrument

★ Horn selection switch at the back of the machine (must be same as the actual installation of horn for new machine)

★NOTE: Please select correct horn (size), for example interface displays Φ6, then you must select Φ6 horn. And the switch at the back panel for horn shall be also Φ6.



★After the horn is used for a long time, when appear honeycomb, make it flat with file. If the ultrasonic wave cannot be generated normally, you can change the horn switch on the back board until the ultrasonic wave is normal.

If the ultrasonic wave cannot be generated normally when open the machine (voltage instability or external interference, can change the horn switch on the back board until the ultrasonic wave is normal

Chapter 2 Diagram

2.1 Removal and installation horn Diagram 3

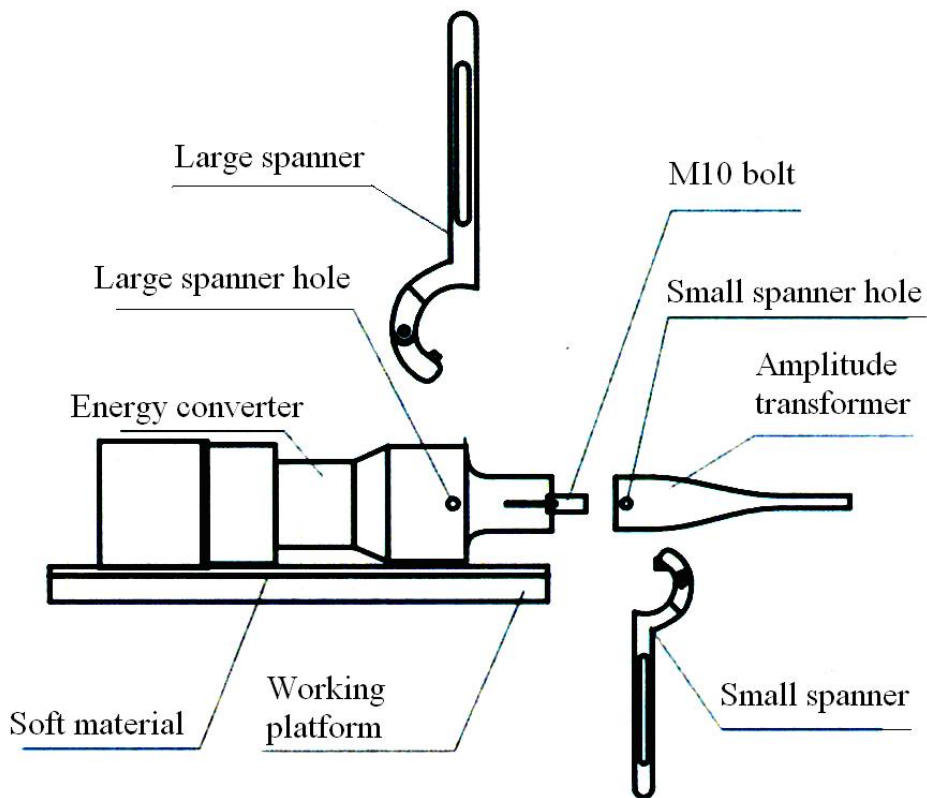

Diagram 3 Removal and installation horn

- Push the energy converter on the chair with soft materials (such as towel). Put the small spanner into the horn spanner hole and the large spanner into the transducer spanner hole. The large and small spanners shall be oriented to the left and right.
- You stand facing the horn, and hold the large spanner with left hand and small spanner with right hand. Tighten downward with both hands (**must be tightened**)
- When changing the horn, such as the M10 screw on the horn, remove the bolt out by hand, and then fasten the bolts on the transducer, and **must be tightened**. If the bolts on the horn, Hex wrench cannot be twisted, you can knock the bolts on the wood materials for a few times then can twist

2.2 Examples of experimental data for some samples

(Please refer to Φ 6mm horn)

Experimental content	Ultrasonic time (S)	interval time (S)	Total working time (Minute)	Power (%)	container (ml)	Broken rate (%)
Treponema palladium	1.5	2	10—20	30	20	Above 90
staphylococcus	1.5	2	10—25	35	20	Above 90
Mouse sciatic nerve	2	3	10—15	35	20	Above 92
Mouse liver	2	3	5—15	45	30	Above 95
Liver cell enzyme extraction	2	3	5—10	50	30	Above 95
Escherichia coli	2	3	10—15	50	50	Above 93
Pseudomonas aeruginosa	2	3	5—10	60	50	Above 92



2.3 Packing List

1. Ultrasonic generator	1 set
2. Sonic system (transducer components+ 6mm horn)	1set
3. Sound proof box (another package)	1 pc
4. Lift Tray (inside of sound proof box)	1 pair
5. Power cable	1pc
6. Fuse (Inside the power cord bag)	2 pcs
7. User manual	1pc
8. Temperature probe	1pc
9. Special wrench (for amplitude pole removing)	1set

