

Series YR03387  
Hand Wheel Vertical Autoclave  
**Instruction Manual**

Thank you very much for purchasing our Autoclave model series YR03387.

Please read the “Operating Instructions” and “Warranty” before operating this unit to assure proper operation. After reading these documents, be sure to store them securely together with the “Warranty” at a hand place for future reference.



**Warning:** Before operating the unit, be sure to read carefully and fully understand important warnings in the operating instructions.



OUR SERVICES

## Benefits and Support

In Kalstein France, we take care of the full satisfaction of our customers, that is why we provide value-added services of the highest level based on our experience.



### Online Inductions and Trainings

In any part of the world, receive your induction or training from our specialized team of engineers



### Quick Response

Our work team is always available to response all your consults or questions, in order to support you in any situation.

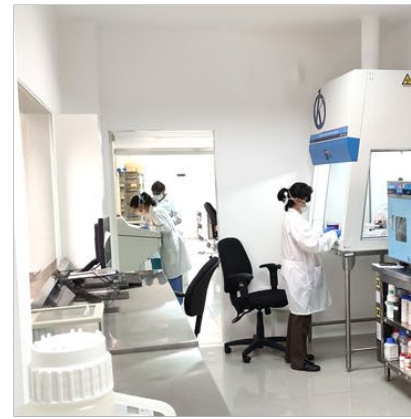

### #Letsgivemore

Thanks to your purchase, a donation will be made to a non-profit foundation that fights against breast cancer and helps most vulnerable communities.



### Technical Support

Enjoy of personalized advice for the correct preventive and corrective maintenance of your equipment, thanks to Kalstein's manuals and articles, special catalogues and video tutorials.



### Delivery Logistics

We take care of all the necessary logistics for the dispatch of your goods, whether is by sea, land or air.



### Kalstein Worldwide

With more than 25 years growing with our customers, Kalstein's multiformat and modern content, is now present in more than 10 countries and increasing.

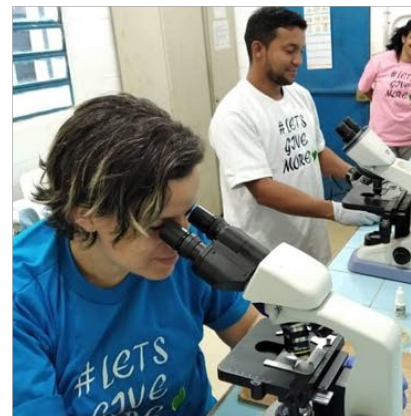



<https://kalstein.eu/>

---





Thank you for choosing our steam sterilizer.

Prior to operating this instrument, please read the operations manual carefully and follow all installation instructions.

#### IMPORTANT NOTICE

If you can't open the door, please unlock the door according to the instructions "How to open the door in case of power outage" in the manual.

Need maintenance

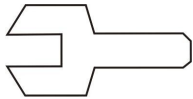

If this picture appears on the screen when power On or E88 appears on the report, please call your dealer or local maintenance service. Your steam sterilizer needs general maintenance.



Document: Version 00D20000V2.10  
Subject to technical changes

Save these instructions

# Content

1. General	4	4 Scope of manual 4 Intended use 4 General safety instructions 4 Standards and directives 5 Symbols
2. Description of the sterilizer	5	5 Sterilizer views 6 Control panel 6 Technical specification 6 Packing content
3. Installation	7	7 General conditions 7 Power supply connection 7 Location requirements
4. Setup	8	8 Fill the distilled water tank 8 Preparation of the sterilization materials 9 Basic set 9. About device 9 Advance set
5. Operation	11	12 Load the sterilization chamber 12 Select the program 12 Start the sterilization program 12 End of cycle 12 Manually interruption of the cycle 13 Test Program 14 Data 14 Save report 14 Printer (optional) 16 Labels (optional)
6. Maintenance	16	16 Clean the distilled water tank 16 Replacement of the bacteriological filter 16 Clean Chamber, trays and tray Rack 17 Door adjustment 17 Replacement of the door seal ring 17 The drain valve
7. Troubleshooting	18	18 Error code description
8. Transportation and storage	19	19 Transportation and storage conditions
9. Safety devices	19	19. Safety device description
11. Appendix	20	20 Water properties/characteristics 21 Diagrams of the sterilization programs



# 1 General

---

## Scope of Manual

---

This manual contains information concerning the installation, operation and maintenance of the steam sterilizers. To ensure proper performance of the sterilizer, the instructions given in this manual should be thoroughly understood and followed. Keep the manual near the sterilizer in an accessible location for future reference.

## Intended Use

---

The steam sterilizer described in this manual is intended for the sterilization in all medical, dental, beauty, vet and tattoo fields of the following types of instrument loads: solid, porous, hollow loads type A and hollow loads type B, un-wrapped, single wrapped and double wrapped, liquid, that are compatible with steam sterilization.

## General Safety Instructions

---

- Read and understand this manual before attempting to install or operate the sterilizer.
- Make sure that all the installation conditions are fully complied with.
- Ensure that the voltage agrees with the supply voltage specified on the supply on the type plate of the sterilizer.
- This appliance must be grounded. Connect only to a properly grounded outlet.
- Do not cover or block any openings on this appliance.
- Use this appliance only for its intended use as described in this manual.
- Do not exceed the maximum weight limit of the loads specified in this manual.
- Do not operate this appliance if it has a damaged cord or plug if it is not working properly or if it has been damaged or dropped.
- Never put into the sterilizer inflammables or explosive products.
- The sterilizer may not be operated in areas in which gas or any other explosive volatile substance is present.
- Installation and repair work should only be performed by authorized service technicians. Work by unqualified persons could be dangerous and may void the warranty.

## Standards and directives

---

The steam sterilizers were designed and produced in conformity with the following directives and standards:

Directives:

97/23/CE Pressure equipment.

93/42/EEC Medical devices (class II b).

Standards:

EN 13060 Relative to small steam sterilizers.

EN 61010-1 Safety regulations for laboratory devices - Part 1: General regulations.

EN 61010-2-040 Safety regulations specific to sterilizers used in the processing of medical material.

EN 61326-1 Electromagnetic compatibility regulations for laboratory devices.

## Symbols

For safe operation, please pay close attention to the alert symbols below which can be found on the sterilizer and throughout this manual.



Important information (Caution)



Hot surface



Ground connection

## 2 Description of the sterilizer

### Sterilizer views

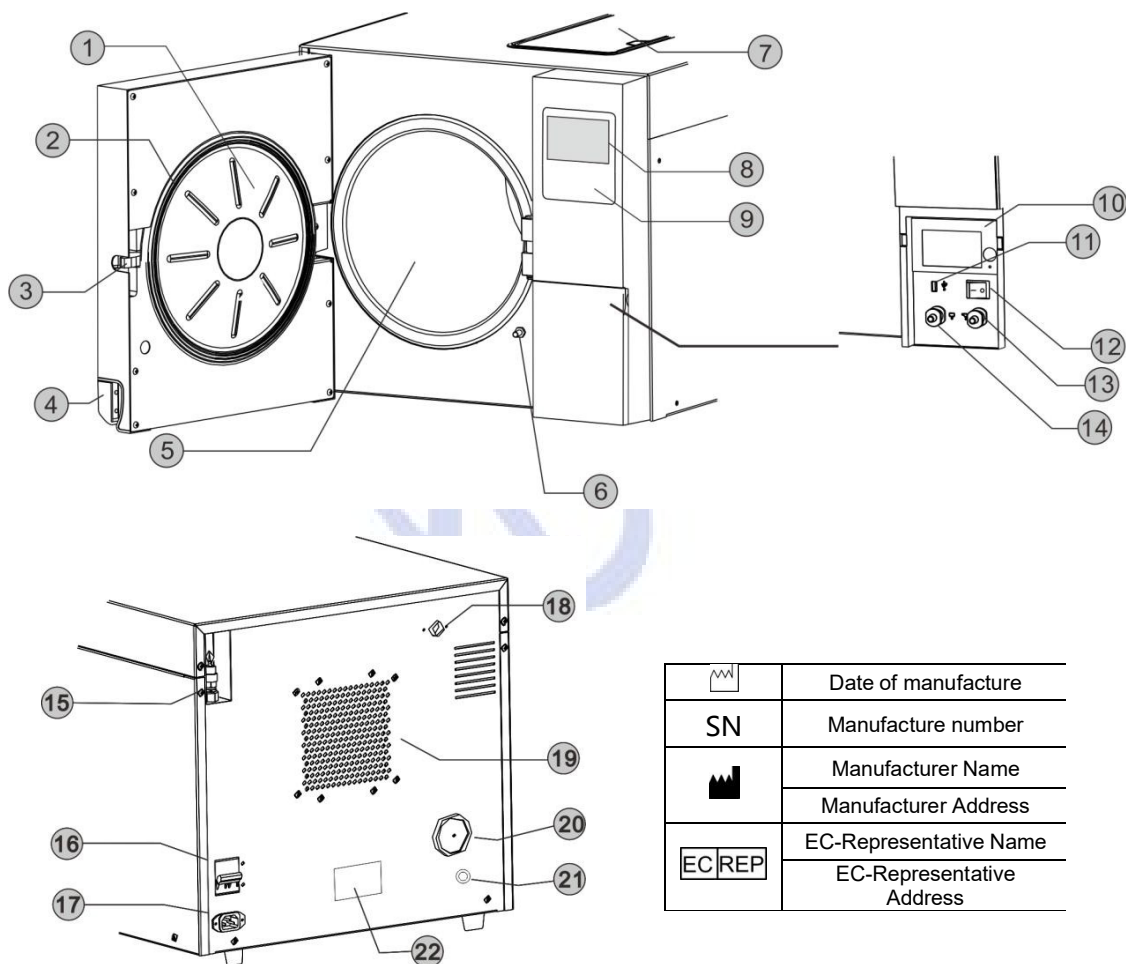

	Date of manufacture
SN	Manufacture number
	Manufacturer Name
	Manufacturer Address
EC REP	EC-Representative Name
	EC-Representative Address

1. Door	9. Control panel	16. Circuit breaker
2. Door seal ring	10. Printer	17. Power socket
3. Door lock	11. USB port	18. Used water tank vent
4. Door handle	12. Main switch	19. Condenser vent
5. Chamber	13. Distilled water outlet/ Distilled water inlet*	20. Bacteriological filter
6. Door switch	14. Used water tank outlet	21. Distilled water drain*
7. Distilled water tank	15. Safety valve	22. Rating plate
8. LCD		

\*Models equipped with external water filling function.

### Control panel

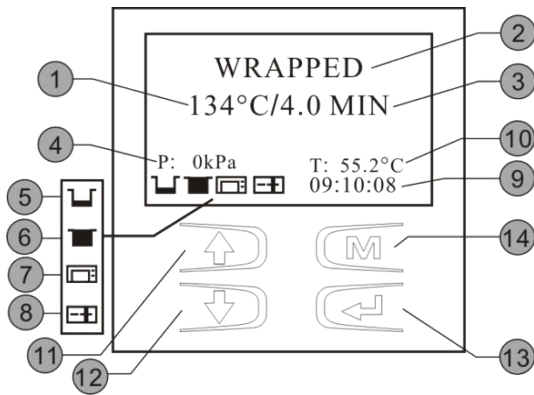

- 1 Program temperature
- 2 Program
- 3 Holding time
- 4 Pressure
- 5 Distilled water / Fill it flashing.
- 6 Filling the tank
- 7 Bad water quality
- 8 Used water tank full / Drain if flashing
- 7 Printer status
- 8 Door open
- 8 Door closed
- 8 Door blocked
- 9 Time
- 10 Current internal temperature
- 11 Up button
- 12 Down button
- 13 Enter button
- 14 Menu button

## Technical specifications

Model	YR03387	YR03388	YR03389	YR03390	YR03385C
Chamber (mm)	Φ170 x 320	φ200 x 360	φ247 x 350	φ247 x 450	φ247 x 625
Overall dimensions (W*H*D)	420*370*525	420*370*595	490*455*600	490*455*690	490*455*890
Net Weight (kg)	37	41	47	53	65
Nominal power (VA)	1750	1750	1750	1750	2300
Rated Voltage	230-240V;50 Hz				
Sterilization temperatures	121°C/134°C				
Capacity of the distilled water tank	2.5 L (Water at level Max.) Approx.				
	0.5 L (Water at level Min.) Approx.				
Circuit breaker	F16A /400 V				
Operation temperature	5°C ~ 40°C				
Operation relative humidity	Max. 80%, non-condensing				
Max. Noise level	<70 dB				
Atmospheric pressure	76 kPa ~ 106 kPa				

## Packing content

Item	Accessories	Quantity
1	Instruments tray	YR03387: 2 units YR03388/89/90/85C: 3 units
2	Instruments tray rack	1
3	Draining hose	2
4	Door Seal	1
5	Try handle	1
6	Instructions Manual	1



### 3 Installation

#### General conditions

- Position the device on a plane surface with a minimum capacity of 60 kgs.
- The sterilizer should be placed on a level worktable.
- Leave at least 10cm between the device rear part and the wall. The clearance required to open the door is 40cm.
- Position the sterilizer at such a height as to make it possible for the operator to check the whole sterilization chamber and carry out the normal cleaning operations.
- The room where the device is installed must be sufficiently ventilated.
- Do not install the device near washing basins, taps, etc. where it is likely to be splashed.
- Do not lean on the door when it is opened.
- Do not place trays, papers, fluid containers or other objects on the sterilizer.

#### Power supply connection

Check the label on the back panel of sterilizer to verify the voltage rating for the unit. Failure to connect the sterilizer to an appropriate power supply could result in damage to the unit and electrical shock to personnel.

Plug power cord into a properly polarized and grounded receptacle rated. A dedicated circuit only used for the sterilizer is recommended. Never connect the device pin to reductions of any type.

#### Location requirements and dimensions (mm)

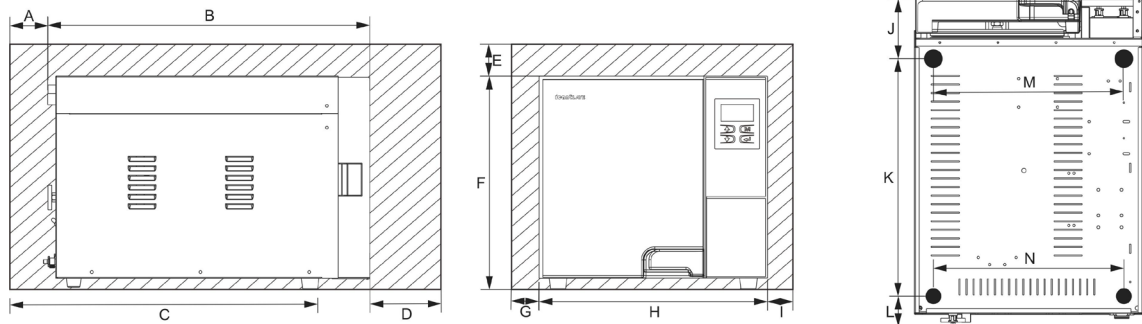

Model	YR03387	YR03388	YR03389	YR03390	YR03385C
A	100	100	100	100	100
B	542	582	595	685	875
C	552	592	605	695	885
D	350	350	400	400	400
E	100	100	100	100	100
F	367	367	450	450	450
G	50	50	50	50	50
H	410	410	483	483	483
I	50	50	50	50	50
J	130	130	135	130	130
K	360	400	405	500	690
L	52	52	55	55	55
M	330	330	403	403	403
N	330	330	403	403	403

---

## 4Setup

Connect the power cord to an outlet of the appropriate voltage.

Turn on the main power switch on the right side. Open the door to remove all of the inner contents for unpacking. After switching on, the machine turns on the LCD and shows the door position, water level, working program, date, time, etc.

---

### Fill the distilled water tank

---

#### Manual water filling

When the level of distilled water reaches a minimum level, the distilled water tank icon will flash and beep three times.

Press the button on the tank lid and open it to the maximum position.

Fill it carefully with distilled water.

If exceeds the maximum level, an alarm will sound, and the distilled water tank icon will blink.

---

#### From an external container (Optional)

Connect the supplied tube to the front (right)connector of the sterilizer.

Insert the other end of the tube with the filter into the container with distilled water.

Maintain ↓ button pressed until the icon  appears.

The pump charges the clean water tank located at the top of the sterilizer, the capacity of the tank is 2.5 liters approx.

If after 180 seconds the tank has not reached the maximum level, the pump will stop, and it will be necessary to press again the distilled water tank icon to finish filling the tank.

Once the maximum level has been reached, the pump stops automatically.

---

#### Drain the distilled water tank\*

Attach the drain hose on a fitting connection located on the back of the sterilizer. Pull the connector to start the draining.

Attention: The capacity of the distilled water tank is approximately 2.5 liters

\*for models equipped with automatic water filling (Optional).

---

#### Drain the used water tank

Attach the drain hose on the drain connector located inside the service door at the left.

Attention: The capacity of the used water tank is approximately 1.5 liters

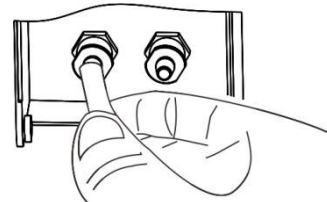

---

#### Preparation of sterilization materials

For the most effective sterilization and to preserve the sample, please follow below:

- Clean instruments immediately after used.
- Treat the instruments by ultrasound cleaner.
- Residual chemicals left over after cleaning and disinfecting process may damage and corrode parts of the sterilizer, always rinse off the instruments using distilled water.

- Follow instrument manufacturer’s guidelines and recommendations for handing and cleaning instruments prior to sterilization.
- Check the manufacturer’s instructions as to proper procedure for sterilizing of each item.
- Arrange the samples of different materials on different trays or with at least 3cm of space between them.
- Clean and dry instruments thoroughly before placing them into tray.
- Always insert a sterilization paper or cloth between the tray and sample to avoid direct contact.
- Arrange the containers (glasses, cups, test-tubes, etc.) on one side or inverted position, avoiding possible water stagnation.
- Don’t stack the trays one above the other or put them in direct contact with the walls of the sterilization chamber.
- Always use the instrument tray handle.
- Wrap the samples one by one or, if more tools have to be set in the same bag, verify that these are made of the same material.
- Don’t use metallic clips, pins or other, as this jeopardizes the maintenance of the sterilizer.
- Don’t overload the trays over the stated limit (see appendix 2).

## Basic Set

---

From the main menu,, select "Basic Set".



The “Basic Set” menu permits to set the following options:

\*Date \*Time \*Language

Select the “Basic Set” from the main menu by pressing **M** button.

Select the item by pressing **M** button. The unit you selected will be lighted.

Adjust the value by pressing **↑↓** buttons. Press **M** button to select the next item.

Press **←** button to save and back.

Abbreviation of language options

CHN	Chinese	ENG	English	DEU	German	ESP	Spanish
PL	Polish	FR	French	HUN	Hungary	ROM	Romanian
NL	Dutch	LTU	Lithuanian	LAT	Latvian	CZE	Czech
ITA	Italian	RUS	Russian	PT	Portuguese	HR	Croatian

Note: The Counter (cycle No) cannot be set by the operator.

## About device

---

Select “About device” from the main menu then press **M** button.

Press **←** button to back.

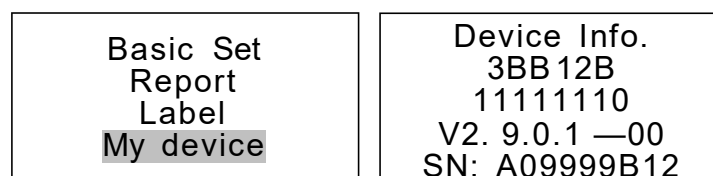



## Advance Set

The "Setup" menu permits to set the following options:

\*Parameter \*Unit \*Preheat \*Expiry date (labels) \*Water quality (sensor)  
and see the information of: \*Last error

Select "Setup" from the main menu by pressing **M** button.

Input the password digit to digit by pressing **↑↓** and **M** button to go next.

Password: 1111

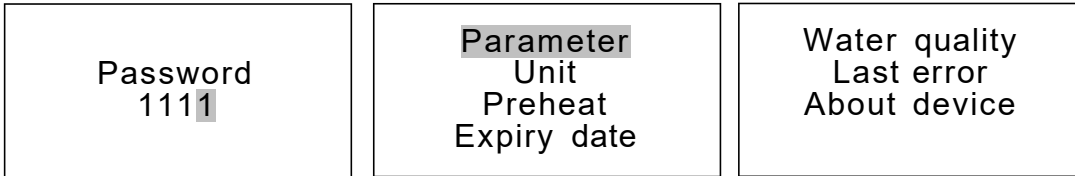

## Parameter

The "Parameter" menu permits to set the following options:

\*Holding time \*Dry time

Select "Parameter" from the menu by pressing **M** button.

Select the program by pressing **↑↓** then press **M** button.

Select the parameter by pressing **M** button. Adjust it by pressing **↑↓**.

Press **←** button to save and back.

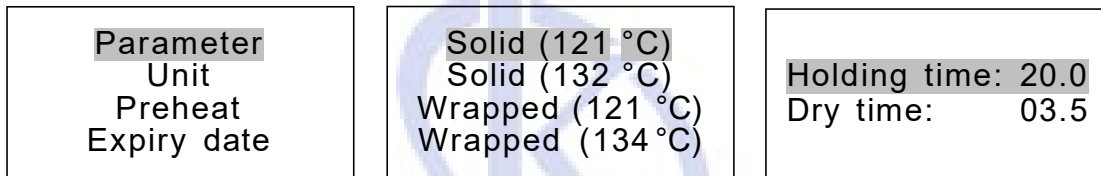

## Unit

Select "Unit" from the menu by pressing **M** button.

Select the parameter by pressing **M** button. Adjust it by pressing **↑↓**.

Press **←** button to save and back.

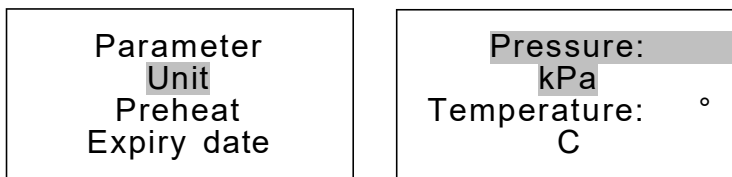

## Preheat

When this mode is activated, the chamber and steam generator start to warm until it reaches the minimum temperature to begin a sterilization cycle, this helps to reduce the total cycle time and the drying efficiency. The "Preheat" mode will be deactivated after one hour of inactivity.

Select "Preheat" from the menu by pressing **M** button.

Adjust it by pressing **↑↓**.

Press **←** button to save and back.

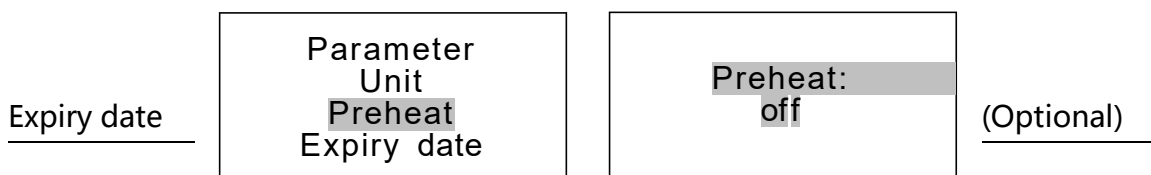



To modify the expiration date of the labels, select “Expire date” from the menu by pressing **M** button.

Adjust it by pressing **↑↓**.

Press **←** button to save and back.

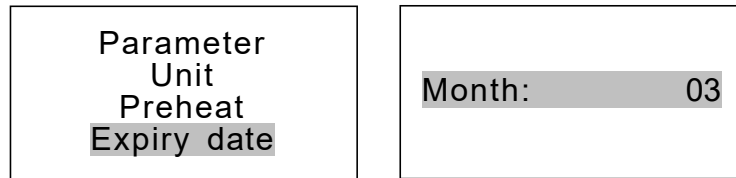

### Water quality (optional)

If your sterilizer is equipped with a water quality sensor and you want to deactivate it, select “Water quality” from the menu by pressing **M** button.

Adjust it by pressing **↑↓**.

Press **←** button to save and back.

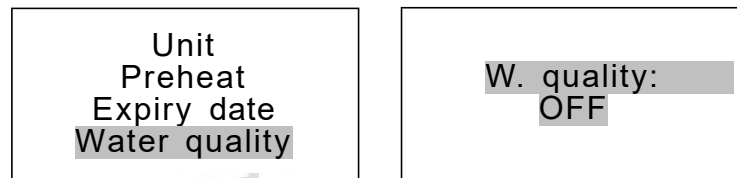

### Last Error

In order to help the technical assistance process, the most relevant information corresponding to the last error can be displayed on the screen.

Select “Last error” from the menu by pressing **M** button.

Press **←** button to back.

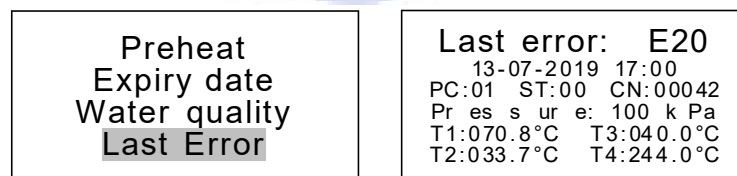

## 5 Operation

### Prerequisites

Switch On.

Check the status of the icons in the screen . (Refer to point 2. Description of the sterilizer)

Load

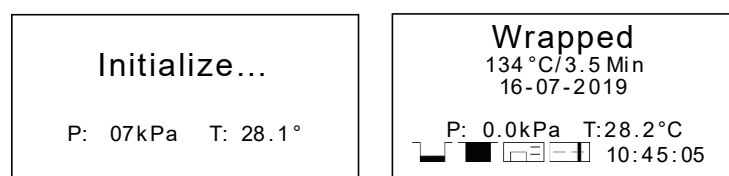

Open the door then placed the trays inside the chamber by the tray handle.  
After the instruments are loaded, you may close the door.

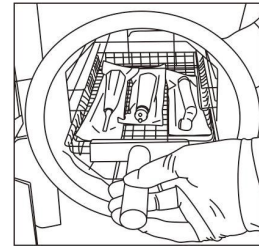

### Select the program

Enter to the main menu by pressing **M** button, Select "Program". Select the program by pressing **↑↓** then press **M** to confirm program, in the screen will appear the information of selected program as the temperature and sterilization time (holding time), also the date, time, current pressure and current temperature.

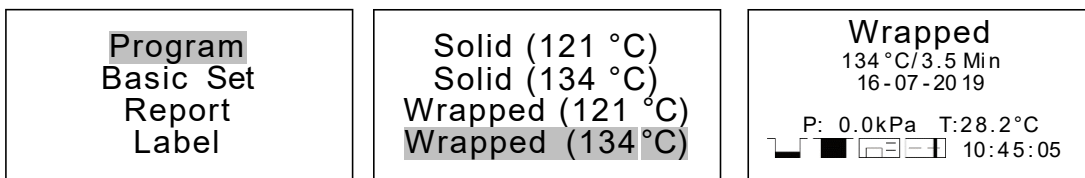

### Start the sterilization program

Press **←** to start the cycle. The stage, conditions and the status of the cycle will appear on the display. The sterilizers will perform the program automatically. (see appendix 2).

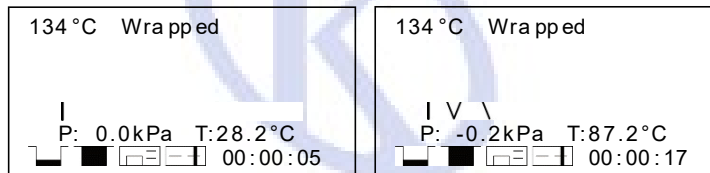

### End of the cycle

Once the cycle is completed, "End" will appear at the end of the graphic, the printer will print out and the digital report saved in the USB memory is these are connected.

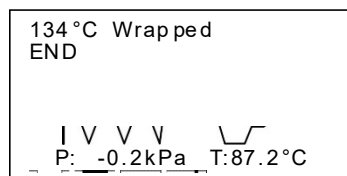

Caution: Always use the tray handle to load or unload the tray into the sterilizer. Failure to do so can result in burning.

### Manually interruption of the cycle

To interrupt a started cycle prematurely, hold **←** for 3 seconds.  
If the cycle is manually interrupted after it reaches the drying phase, the items inside the sterilizer may be considered sterile and considering that the cycle has been interrupted during the drying phase the materials and instruments inside the chamber may be wet.

Note: If the cycle is manually interrupted before it reaches the drying phase, the items inside the sterilizer must be considered not sterile. N20 will appear on the screen. (see Error code description).



Caution: Depending on the phase of the cycle, steam and water can escape from the sterilization chamber when you open the door.

## Test Programs

---

### Helix test

---

Put the Helix test device into the chamber, then close the door.

Select "Program" from the main menu by pressing **↑↓** then **M** to enter in the menu, select "Helix test"; in the screen will appear the information as temperature and sterilization time (holding time), also the date, time, current pressure and current temperature.

Press **←** to start the cycle. The stage, conditions and the status of the cycle will appear on the display. The sterilizers will perform the program automatically. (see appendix 2).

After finishing the cycle, you may check the indicator and evaluate the result according with the instructions of the test manufacturer.

### B&D test

---

Put the B&D test package into the chamber, then close the door.

Select "Program" from the main menu by pressing **↑↓** then **M** to enter in the menu, select B&D test, in the screen will appear the information as the temperature and sterilization time (holding time), also the date, time, current pressure and current temperature.

Press **←** to start the cycle. The stage, conditions and the status of the cycle will appear on the display. The sterilizers will perform the program automatically. (see appendix 2).

After finishing the cycle, you may check the indicator and evaluate the result according with the instructions of the test manufacturer.

### Vacuum Test

---

Select "Program" from the main menu by pressing **↑↓** then **M** to enter in the menu, select "Vacuum test".

After closing the door, press **←** to start the cycle. The stage, conditions and the status of the cycle will appear on the display. The sterilizers will perform the program automatically. (see appendix 2).

In compliance with EN 13060, the test requires that the air leakage rate less than or equal to 0.13 kPa/min. during 10 minutes.

If leakage rate is not greater 0.13, it will show Success.

If the temperature difference between the max. Temperature and the Min. is above 3°C, it will show void. That means the result of the test is fail. You need run the vacuum test again after the chamber has cooled down.

### Data

---

The internal memory will store the information of the last 9999 cycles.

## USB Flash memory (Optional)

---

A USB drive can be used as a method of storing a report of the cycle. To do so, insert the USB drive into the slot located on the service door of the sterilizer.

The information will automatically output directly to the USB drive after the cycle has completed. The name of the file is determined by the serial number of the machine and the cycle number.

For example:

The serial number is E00001. The cycle number is 0012.

The file name in the USB stick is 01001200.txt.

The first two numbers represent machine number.

The middle four numbers represent cycle number.

The last two numbers represent error code.

E.g. 00:no error;01: error E01

## Printer (Optional)

---

If installed, you can see the icon in the screen stop flashing.

At the end of each cycle the printer will print out a report of the cycle.

Note: if there is no paper inside the printer; the icon will flash.

## Report

---

### Internal Memory

In this menu you can get the information of all the cycles stored in the internal memory of the sterilizer.

Select "Report" from the main menu and press **M** button, you will see the list of records.

Select the record by pressing **↑↓** button.

Press **M** button to print and save the report.

Press **←** button to exit.

Program	00012
Basic Set	00011
Report	00010
Label	00009

## Sample of a printer report

---

When reading printed data records, refer to the diagram below:



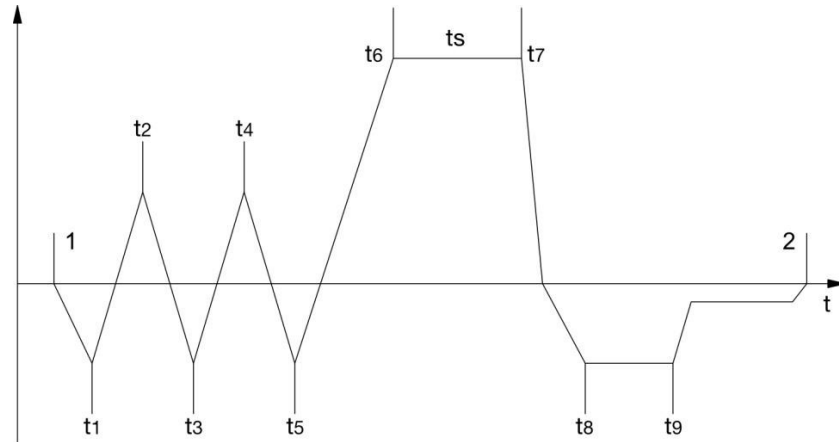

```
=====
Program: WRAPPED
Temperature: 134C
Pressure: 206.0 kPa
Drying Time: 08Min
Holding Time: 4.0Min
-----
Time  Temp. Pressure
Start 12:28:17 089.0C
T1: 12:31:32 087.1C -075.0kPa
T2: 12:33:43 110.2C 052.0kPa
T3: 12:36:37 088.9C -075.0kPa
T4: 12:39:20 114.7C 053.7kPa
T5: 12:43:37 087.9C -075.0kPa
T6: 12:50:40 134.8C 206.0kPa
TS: 134.7C 209.5kPa
Max. Temperature:135.2C
Min. Temperature:134.3C
Max. Pressure:214.0kPa
Min. Pressure:204.9kPa
T7: 12:54:39 134.4C 211.4kPa
T8: 12:57:36 102.1C -060.0kPa
T9: 12:59:54 098.2C -060.0kPa
End 13:04:07 102.4C
-----
Cycle No.: 00017
Ster. Value: Success
Date: 2017-06-07
SN:E54723
Operator:
v 2B00V2.5
=====
```

```
=====
Program:Vacuum test
Tp:1°C
P1:-75.0kPa
P2:-74.0kPa
rate of pressure rise:0.10
Start Time:08:22
End Time:09:01
Date:2017-07-19
Test Value:Success
SN:E00001
Operator:
=====
```

## Print labels

Select "Labels" from the main menu and press **M** button to enter in the menu.

Select the cycle number by pressing **M** button. Choose the labels quantity by pressing **↑↓** then press **M** button to print. Press **←** button to exit.

Program Basic Set Report Label	00012 00011 00010 00009	QT: 01
---	----------------------------------	--------

## 6 Maintenance

To ensure proper operation and maximum steam sterilizer life, carefully follow all recommendations for periodic maintenance.

One of the most important steps you can take to prevent problems with your sterilizer is to use only distilled water.

Frequency	Number of cycles	Maintenance operation
Monthly	50	Clean the door seal
		Clean the filter inside the chamber and in the clean water tank
		Clean the chamber the trays and the rack
		Clean the external surface
Every 3 months	200	Clean the distilled water tank
		Replace the bacteriological filter
Every year	800	Replace the door seal

### Clean the distilled water tank

Disconnect the main cable.

Drain the tank completely using the drain connector at the back of the sterilizer and leave it connected into the connector in an open position.

Clean the internal surface with a soft sponge and a small soft brush for the areas difficult to reach using and a distilled water.

Remove the filter and clean it with a small soft brush and mild soap, rinse it with distilled water, and put it back in to the position.

### Replacement of the bacteriological filter.

The bacteriological filter is in the back of the sterilizer. Unscrew the filter by hand anti-clockwise.

Place the new bacteriological filter.

Screw the new filter by hand clockwise.

Note: Do not operate sterilizer without filters in place.

### Clean chamber, door seal ring, trays, and tray rack.

Remove the trays and tray rack from the chamber.

Clean trays, rack and inside of the chamber with mild soap.

Rinse the trays, rack and inside of the chamber with a smooth cloth and distilled water.

Examine door seal for possible damage.

Clean door seal and mating surfaces with a damp cloth.

Note: Do not use bleaching agents or any abrasive materials or substances in the chamber.

Failure to comply may cause damage to the chamber and/or other components.



Caution: To prevent burns, let the unit cool before cleaning gaskets and touch the surface.

## Door adjustment

Under normal circumstances, the chamber door does not require adjustments. However, if the seal fails (resulting in steam leaking from the front of the chamber), you may adjust it.

Open the door.

Insert the spanner tool in the gap beneath the plastic cover; use the spanner to grip the adjusting nut. Turn the nut counter clockwise as the figure below. This will tighten the sealing plate.

Turn the nut until the sealing plate is tight. If the door knob is too tight, you may also turn the nut clockwise to loosen it.

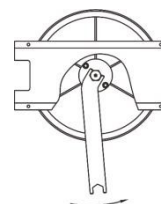
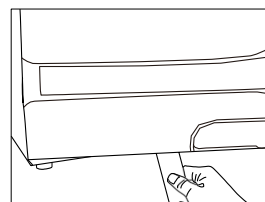

Caution: Never adjust the chamber door while the door is closed.

## Replacement of the door seal ring

Open the chamber door. Remove the door seal ring carefully by hand.

Clean the door seal ring carefully with a smooth cloth with distilled water.

Moisten the new seal with distilled water.

Insert the new seal and tap in sequence as follows:

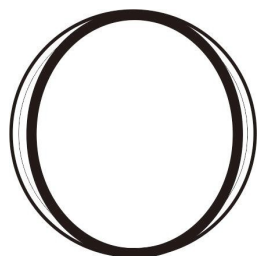

Press in the top and bottom of the door seal.

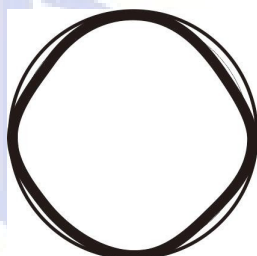

Press in the left and right sides of the door seal.

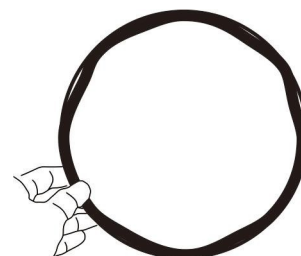

Press the remaining sections of the seal.



Caution: Please ensure the chamber and the door are cold prior to replacing the seal ring.

## The drain valves

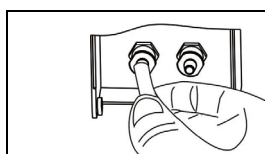

1. Press the included hose onto the drain valve firmly.

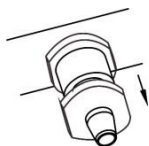

2. Pull the drain valve outward to drain the tank.

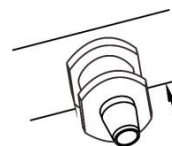

3. Push the drain valve back after draining the tank.

## 7 Troubleshooting

Code	Description	Proposed solution
------	-------------	-------------------



E1	Steam generator temperature sensor error.	Power off & run a new cycle Contact your supplier if error persists.
E2	Inner temperature sensor error.	Power off & run a new cycle Contact your supplier if error persists.
E3	Temperature sensor of the chamber wall error.	Carefully ensure that the chamber wall is heated and contact your supplier.
E5	Fail to release the pressure.	Power off & run a new cycle Contact your supplier if error persists.
E6	Door lock problem during the cycle.	Make sure you had closed the door properly. check the door switch.
E7	Error between temperature and pressure correlation.	Power off & run a new cycle Contact your supplier if error persists.
E8	Error between temperature and pressure correlation.	Power off & run a new cycle Contact your supplier if error persists.
E9	Failure to hold temperature.	Ensure the distilled tank isn't empty. Check the inner temperature sensor. Check somewhere for leaking.
E10	The door locking system doesn't work.	The electromagnet of locking system doesn't work. The switch of locking system doesn't work.
E11	Failure to preheat the steam generator.	Power off & run a new cycle Contact your supplier if error persists.
E12	Failure to preheat the chamber.	Power off & run a new cycle Contact your supplier if error persists.
E13	Vacuum failed.	Power off & run a new cycle Contact your supplier if error persists.
E15	Inner temperature sensor error #2*	Power off & run a new cycle Contact your supplier if error persists.
E16	Pressure error	Replace the air filter Power off & run a new cycle Contact your supplier if error persists.
N20	Program manually interrupted	Reset the error from main screen.
E22	Vacuum test failure	Somewhere is leaking. Check the door seal. Or contact your supplier if error persists.
N23	Result of vacuum test is void	The temperature of the chamber is high. Try again after the chamber has cooled down.
E24	It takes too long time to enter the next status.	Check somewhere leaking. Or contact your supplier if error persists.
N27	The vacuum test fails.	Switch off. Then switch on after the chamber cool down and try again.
E28	The pressure is overload.	Power off and contact your supplier if error persists.
E30	Vacuum failed.	Power off & run a new cycle Contact your supplier if error persists.
E31	Inner temperature sensor error #2*	Power off & run a new cycle Contact your supplier if error persists.

## 8 Transportation and storage

---

Switch off the sterilizer before transportation or storage.  
Pull out the plug. Let the machine cool down.  
Drain the distilled water tank and the used water tank.

Conditions for transport and storage  
Temperature: -20°C ~ +50°C  
Relative humidity: ≤ 85%  
Atmospheric pressure: 50kPa~ 106kPa.

## 9 Safety devices

---

1. Main breaker: Protection of the instrument against possible failures of the heating resistor.  
Action: Interruption of the electric power supply.
2. Thermal cutouts on the main transformer winding: protection against possible short circuit and main transformer primary winding overheating  
Action: Temporary interruption of winding.
3. Safety valve: Protection against possible sterilization chamber over-pressure.  
Action: Release of the steam and restoration of the safety pressure.
4. Safety micro-switch for the door status: Comparison for the correct closing position of the door.  
Action: Signal of the wrong position of the door
5. Thermostat on chamber heating resistors: Protection for possible overheating of the chamber heating resistors.  
Action: Interruption of the power supply of the chamber resistors.
6. Thermostat on steam generator heating resistors: Protection for possible overheating of the steam generator heating resistors.  
Action: Interruption of the power supply of the steam generator resistors.
7. Door safety lock: Protection against accidental opening of the door.  
Action: Impediment of the accidental opening if the door during the program.
8. Self-leveling hydraulic system: Hydraulic system for the natural pressure leveling in case of manual cycle interruption, alarm or blackout.  
Action: Automatic restoration of the atmospheric pressure inside the chamber.

## Appendix 1

---

### Water properties / Characteristics

Description	Feed water	Condensate
Evaporate residue	≤ 10mg/ l	≤ 1.0mg/kg
Silicium oxide sio2	≤ 1mg/ l	≤ 1.0mg/kg
Iron	≤ 0.2mg/ l	≤ 0.1mg/kg
Cadmium	≤ 0.005mg/ l	≤ 0.05mg/kg
Lead	≤ 0.05mg/ l	≤ 0.1mg/kg
Rest of heavy metals	≤ 0.1mg/ l	≤ 0.1mg/kg
Chloride	≤ 2mg/ l	≤ 0.1mg/kg
Phosphates	≤ 0.5 mg/ l	≤ 0.1mg/kg
Conductivity	≤ 15µs /cm	≤ 3 µs /cm
PH Value	5 – 7.5	5-7
Appearance	Colorless, clean	Colorless, clean
Hardness	0.02 mmol/ l	0.02 mmol/ l

## Appendix 2

### Diagrams of the sterilization programs

Programs <b>YR03387</b>	Temperature (°C)	Pressure (kPa)	Holding time (min)	Total time (min)	Type	Max load (kg)	Max load per tray (kg)
SOLID	134	210	4	15-20	Unwrapped solid material	2.00	0.60
	121	110	20	30-35			
WRAPPED	134	210	4	25-40	Unwrapped solid material	2.00	0.60
	121	110	20	45-50	Single-wrapped solid or hollow material	1.50	0.50
TEXTILE	134	210	8	30-45	Unwrapped porous material	0.50	0.15
					Single-wrapped porous material	0.35	0.10
	121	110	30	55-60	Dual-wrapped porous material	0.25	0.10
					Single-wrapped hollow material	1.50	0.30
					Dual-wrapped solid and hollow material	1.00	0.30
PRION	134	210	18	40-55	Unwrapped porous material	0.50	0.15
					Single-wrapped porous material	0.35	0.10
					Dual-wrapped porous material	0.25	0.10
					Single-wrapped hollow material	1.50	0.30
					Dual-wrapped solid and hollow material	1.00	0.30
LIQUID (Optional)	134	210	10	35-55	Liquid	0.60	0.20
	121	110	30	40-50			
Drying (Optional)	—	—	—	1-20	—	—	—
B&D test	134	210	3.5	10-20	—	—	—
Helix test	134	210	3.5	10-20	—	—	—
Vacuum test	—	—	—	17-20	—	—	—

The time required for sterilizer to be ready for routine use after the power is switched is less than 15 minutes.

The max. Temperature of the 134°C sterilization cycle is 137°C

The max. Temperature of the 121°C sterilization cycle is 124°C



Programs (YR03388)	Temperature (°C)	Pressure (kPa)	Holding time (min)	Total time (min)	Type	Max load (kg)	Max load per tray (kg)
SOLID	134	210	4	15-20	Unwrapped solid material	3.00	1.00
	121	110	20	30-40			
WRAPPED	134	210	4	30-45	Unwrapped solid material	3.00	1.00
	121	110	20	45-50	Single-wrapped solid or hollow material	2.50	0.80
TEXTILE	134	210	8	30-45	Unwrapped porous material	0.75	0.25
					Single-wrapped porous material	0.50	0.15
					Dual-wrapped porous material	0.30	0.10
	121	110	30	55-60	Single-wrapped hollow material	2.50	0.80
					Dual-wrapped solid and hollow material	1.20	0.40
PRION	134	210	18	40-55	Unwrapped porous material	0.75	0.40
					Single-wrapped porous material	0.50	0.15
					Dual-wrapped porous material	0.30	0.10
					Single-wrapped hollow material	2.50	0.80
					Dual-wrapped solid and hollow material	1.20	0.40
LIQUID (optional)	134	210	10	35-55	Liquid	0.80	0.25
	121	110	30	40-50			
Drying (optional)	—	—	—	1-20	—	—	—
B&D test	134	210	3.5	15-25	—	—	—
Helix test	134	210	3.5	15-25	—	—	—
Vacuum test	—	—	—	18-21	—	—	—

The time required for sterilizer to be ready for routine use after the power is switched is less than 15 minutes.

The max. Temperature of the 134°C sterilization cycle is 137°C

The max. Temperature of the 121°C sterilization cycle is 124°C





Programs (YR03389)	Temperature (°C)	Pressure (kPa)	Holding time (min)	Total time (min)	Type	Max load (kg)	Max load per tray (kg)
SOLID	134	210	4	15-30	Unwrapped solid material	4.50	1.20
	121	110	20	30-40			
WRAPPED	134	210	4	30-45	Unwrapped solid material	4.50	1.20
	121	110	20	45-60	Single-wrapped solid or hollow material	3.50	1.10
TEXTILE	134	210	8	35-50	Unwrapped porous material	1.00	0.30
					Single-wrapped porous material	0.80	0.25
	121	110	30	55-70	Dual-wrapped porous material	0.60	0.20
					Single-wrapped hollow material	3.50	1.00
					Dual-wrapped solid and hollow material	1.50	0.50
PRION	134	210	18	45-60	Unwrapped porous material	1.00	0.30
					Single-wrapped porous material	0.80	0.25
					Dual-wrapped porous material	0.60	0.20
					Single-wrapped hollow material	3.50	1.00
					Dual-wrapped solid and hollow material	1.50	0.50
LIQUID (optional)	134	210	10	40-55	Liquid	1.00	0.30
	121	110	30	45-60			
Drying (optional)	—	—	—	1-20	—	—	—
B&D test	134	210	3.5	15-30	—	—	—
Helix test	134	210	3.5	15-30	—	—	—
Vacuum test	—	—	—	19-22	—	—	—

The time required for sterilizer to be ready for routine use after the power is switched is less than 15 minutes.

The max. Temperature of the 134°C sterilization cycle is 137°C

The max. Temperature of the 121°C sterilization cycle is 124°C



Programs (YR03390)	Temperature (°C)	Pressure (kPa)	Holding time (min)	Total time (min)	Type	Max load (kg)	Max load per tray (kg)
SOLID	134	210	4	25-45	Unwrapped solid material	5.00	1.50
	121	110	20	30-60			
WRAPPED	134	210	4	35-60	Unwrapped solid material	5.00	1.50
	121	110	20	35-65	Single-wrapped solid or hollow material	4.00	1.20
TEXTILE	134	210	8	45-65	Unwrapped porous material	1.25	0.40
					Single-wrapped porous material	1.10	0.30
	121	110	30	50-75	Dual-wrapped porous material	0.75	0.25
					Single-wrapped hollow material	4.00	1.25
					Dual-wrapped solid and hollow material	2.00	0.60
PRION	134	210	18	50-75	Unwrapped porous material	1.25	0.40
					Single-wrapped porous material	1.10	0.30
					Dual-wrapped porous material	0.75	0.25
					Single-wrapped hollow material	4.00	1.25
					Dual-wrapped solid and hollow material	2.00	0.60
LIQUID (optional)	134	210	10	35-60	Liquid	1.20	0.40
	121	110	30	35-65			
Drying (optional)	—	—	—	1-20	—	—	—
B&D test	134	210	3.5	28-35	—	—	—
Helix test	134	210	3.5	28-35	—	—	—
Vacuum test	—	—	—	20-25	—	—	—

The time required for sterilizer to be ready for routine use after the power is switched is less than 15 minutes.

The max. Temperature of the 134°C sterilization cycle is 137°C

The max. Temperature of the 121°C sterilization cycle is 124°C



Programs (YR03385C)	Temperature (°C)	Pressure (kPa)	Holding time (min)	Total time (min)	Type	Max load (kg)	Max load per tray (kg)
SOLID	134	210	4	30-45	Unwrapped solid material	6.0	2.0
WRAPPED	134	210	8	45-60	Unwrapped porous material	3.5	2.0
					Single-wrapped porous material	3.0	2.0
					Dual-wrapped porous material	2.5 4.0	2.0 2.0
	121	110	30	50-65	Single-wrapped hollow material	3.5	2.0
					Dual-wrapped solid and hollow material	6.0	2.0
PRION	134	210	18	55-70	Unwrapped porous material	3.5	2.0
					Single-wrapped porous material	3.0	2.0
					Dual-wrapped porous material	2.5	2.0
					Single-wrapped hollow material	4.0	2.0
					Dual-wrapped solid and hollow material	3.5	2.0
LIQUID (optional)	121	110	30	55-70	Liquid	3.5	2.0
Drying (optional)	—	—	—	1-20	—	—	—
B&D test	134	210	3.5	35-40	—	—	—
Helix test	134	210	3.5	35-40	—	—	—
Vacuum test	—	—	—	20-25	—	—	—

The time required for sterilizer to be ready for routine use after the power is switched is less than 15 minutes.

The max. Temperature of the 134°C sterilization cycle is 137°C

The max. Temperature of the 121°C sterilization cycle is 124°C

