



Horizontal Cylindrical Pressure Steam Sterilizer

With Microcomputer control

Model YR05640

Instruction Manual

Thank you very much for purchasing our Kalstein's Horizontal Cylindrical Pressure Steam Sterilizer Model YR05640

Please read the "Operating Instructions" and "Warranty" before operating this unit to assure proper operation. After reading these documents, be sure to store them securely together with the "Warranty" at a hand place for future reference.



Warning: Before operating the unit, be sure to read carefully and fully understand important warnings in the operating instructions.



OUR SERVICES

Benefits and Support

In Kalstein France, we take care of the full satisfaction of our customers, that is why we provide value-added services of the highest level based on our experience.



Online Inductions and Trainings

In any part of the world, receive your induction or training from our specialized team of engineers



Quick Response

Our work team is always available to response all your consults or questions, in order to support you in any situation.



#Letsgivemore

Thanks to your purchase, a donation will be made to a non-profit foundation that fights against breast cancer and helps most vulnerable communities.



Technical Support

Enjoy of personalized advice for the correct preventive and corrective maintenance of your equipment, thanks to Kalstein's manuals and articles, special catalogues and video tutorials.



Delivery Logistics

We take care of all the necessary logistics for the dispatch of your goods, whether is by sea, land or air.



Kalstein Worldwide

With more than 25 years growing with our customers, Kalstein's multiformat and modern content, is now present in more than 10 countries and increasing.





1. Synopsis

YR series horizontal pressure steam sterilizer is the equipment that disinfects and sterilizes the objects with saturated steam, its structure is horizontal and heating way is: electric heating and direct steam heating. It is composed of sterilization room, jacket, shell, door, steam generator, pipe system, control system, indicating system and power-supply system.

2. Application Scope

The product is applicable to disinfect and sterilize medical devices, dressings, glass wares and hydroponics medium etc in the steam method.

3. Normal Working Condition

Normal working condition shall comply with the following conditions:

- a) Environmental Temperature +5°C~+40°C;
- b) Relative Humidity ≤80%RH
- c) Atmospheric Pressure 70kPa~106 kPa;
- d) Water Source Pressure 0.15MPa~0.25MPa;
- e) Steam Source Pressure 0.22MPa~0.27MPa (when heating by connecting external steam source)
- f) Working Power Supply three phase AC 220V±20V, 60Hz±1Hz (Control system)

4. Basic Parameters

Basic Parameters of Sterilizer (Table 1)

No.	Name	YR05640
1	Capacity	150L (Φ440mm x 1000mm)
2	Max.work pressure	0.22MPa
3	Max.work temperature	134°C
4	Heat evenness	≤1
5	Temp.range	40~134°C
6	Timer range	0min~99min
7	Dry time range	0min~99min
8	Power consumption	9KW/AC220V.60Hz/3-P



9	Characteristic	Auto water-in, cooling air release, sterilize timing, air release, dry timing, alarm
10	Safety	Over pressure, over temperature protection device, auto pressure release, lack water and overheat protection, over current power cut off, the door be locked when the pressure inner over 0.027MPa, with the function of interlock
11	Dimension	1400*650*1670mm
12	Trans Dimension	1560*860*1820mm
13	Weight	Net: 340kg / Gross: 430Kg

5. Outline Structure and Composition

a) See Fig. 1 for outline structure of sterilizer

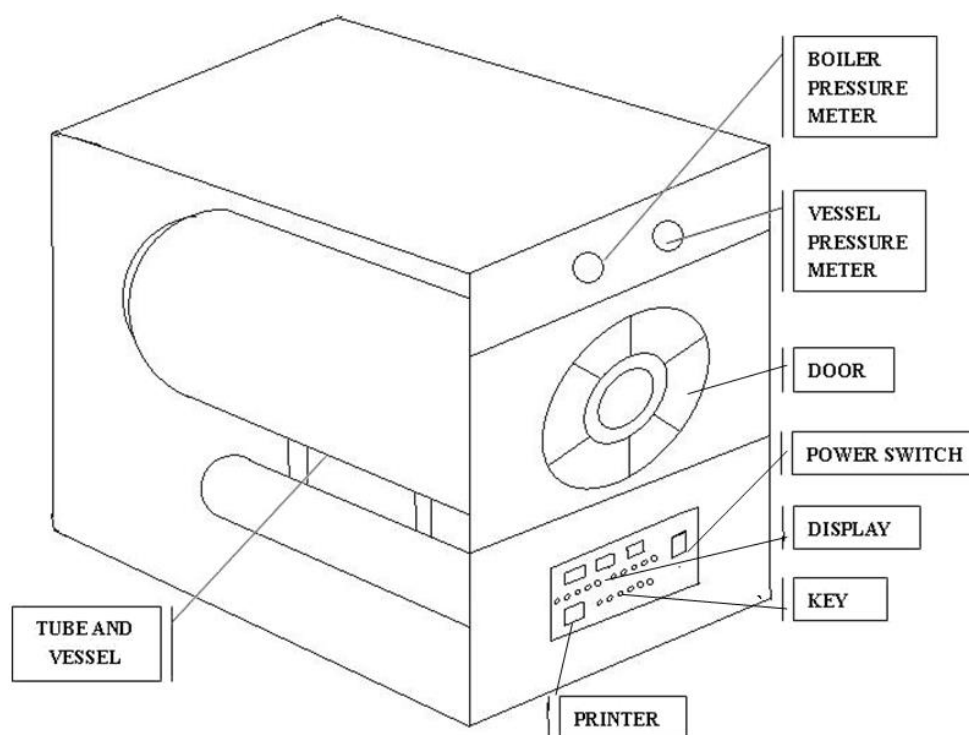

Fig. 1

b) Outline Structure Parts Instruction:

See Fig. 2 for display screen indicating

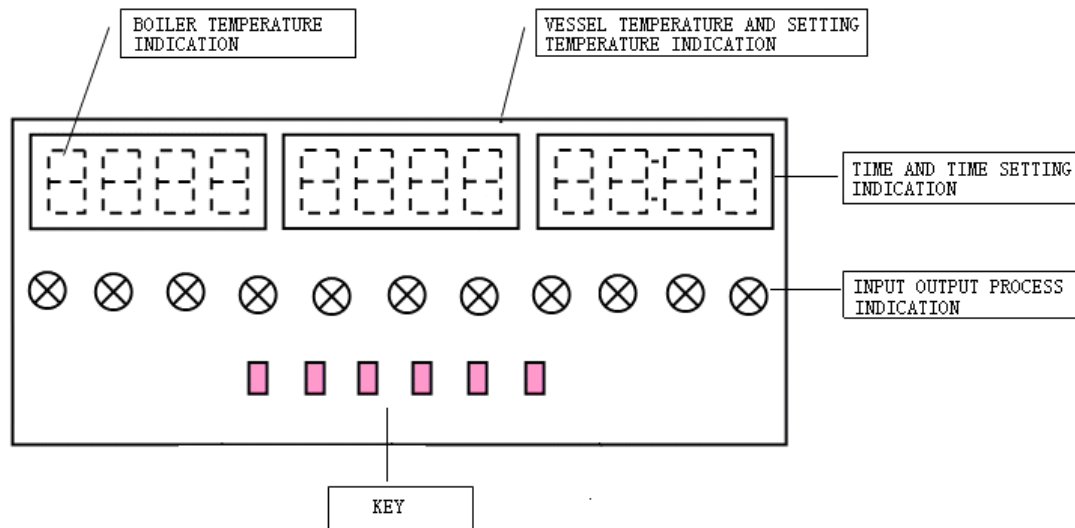

Fig. 2

Nixie Tube

The upper end of the display panel is installing three nixie tubes to display data.

Display contents in correct order are: jacket temperature, sterilization room temperature and time.

Indicator Light

To be used for displaying the input and output and of working process. From left to right in correct order are as below:

Door-----door indicator light; light on means the door has been closed.

Starting-----operation indicator light; light on means the operation stroke has been started, it is in sterilization cycle.

Water Inlet-----Water inlet indicator light; light on means it is inletting water inside evaporator.

Heating-----Heating indicator light, light on means electric heating pipe is in the ohmic heating state.

Sterilization-----Sterilization indicator light, light on means sterilization cycle has been in the sterilization state.

Slow Exhaust-----Slow exhaust indicator light, light on means slow exhaust valve is opened to exhaust steam, which is mainly used for drainage of sterilization room.

Fast Exhaust-----Fast exhaust indicator light, light on means fast exhaust valve is opened to exhaust steam, which is mainly used for freezing air replacement and exhaust steam.

Drying-----Drying indicator light, light on means sterilization cycle has been in the sterilization state.

Full Exhaust-----Full exhaust indicator light, light on means the sterilization room and evaporator are in the



exhausting steam in the fault state.

Water break-----Water break indicator light, light on means evaporator is in low water level state.

Print-----Print indicator light, light on means the printer is printing the sterilization record which has been saved. The sterilization record contains sterilization parameter and time and date before the sterilization is finished. During the period of indicator light on, press printer key again is in vain.

Instruction of other parts on operation panel:

Power switch

It is on the side lower part of sterilizer, which is used for the power supply junction or cut off for equipment control system.

Breaker

It is on the side lower part of sterilizer, which is used for the power supply junction or cut off for the electric heating tube inside the evaporator.

Micro Printer

It is on the side lower part of sterilizer, which is used for printing sterilization record that has been saved.

Pressure Meter

It is on the side upper part of sterilizer,, displaying the pressure of sterilization room and jacket (evaporator) pressure indication of sterilizer.

Operation keys, from left to right in correct order are:

Setting ----- Set sterilization parameters

It is used for setting sterilization temperature (115°C~134 °C) , replacement time (0 minute~60 minutes) , sterilization time (0 minute~99 minutes) , drying time (0 minute~99 minutes) and parameter inquiry during working process.

▲----- Increase key

It is used to set the increase of sterilization parameter value.

▼----- Decrease key

It is used to set the decrease of sterilization parameter value.

Starting-----Starting key



It is used to start the working stroke and set the color system time in control system.

Exhaust Steam-----Exhaust steam key

It is a press-key used to reset the control system when it occurs abnormal situation during working process. After the system is reset, the sterilization room will exhaust steam.

Print -----Print key

It is used to print the parameters of sterilization record process in working.

6. Instruction to Characteristics and Functions of Parts

- (1) The sterilizer body is featured with air-tight double-layer structure, composed of sterilization room and steam jacket. When the steam flows in and full of the jacket, the sterilization room wall will be preheating. There is electromagnetic valve between sterilization room and jacket, pressure steam enters sterilization room from jacket through main valve to moisten and heat articles, so as to achieve the goal of disinfection and sterilization under the influence of moisture and heating. Meanwhile, it can satisfy the requirements of preheating, drying and continuous operation of the objects waiting to be sterilized.
- (2) Cover enclosure outside of the jacket of the sterilization room and fill glass wool with well insulating performance in it, it is favorable to save energy resource and prevent environmental temperature rising too much.
- (3) The open and close for the door of sterilization room adopts radiation bar rotary disk. It is installed with secondary self lock and interlocking safety device, first pull the safety fixing hand wheel when closing the door, displace at the angle of 45 degrees with the joint center of radiation bar rotary disk; after the radiation bar is placed in complete meshing place, turn the hand wheel again, the central rotary disk is placed in axial direction and self-locked by the locating pin. When the pressure inside sterilization room is larger than 0.027MPa, the interlocking device enters automatically to avoid being opened by mis-operation. When the pressure inside sterilization room is less than 0.027MPa, the interlocking device quits, but the rotary disk is still self-locked, hand wheel can be turned counterclockwise, the central rotary disk can quit only in axial direction, the door seal fails gradually and the remaining steam is released to null, that is, release pressure first, then open the door. Only after the hand wheel quit to the outermost, can the safety fixing hand wheel be pulled, withdraw the radiation bar and open the door.
- (4) It sets program function in sterilizer, the air and condensed water in the sterilizer will be discharged



automatically during sterilization process so that the sterilization temperature in sterilization room can approach balance.

- (5) It is installed with steam pressure device to maintain stable pressure; its pressure is controlled within the range of 0.05~0.22MPa and the relative temperature is 110~134°C. Select working temperature pressure through temperature control knob on electric apparatus control box panel.
- (6) It is installed with timer device, with the time set within the range of 0~60 minutes, select working time through time control turn button on electric apparatus control box panel.
- (7) It is installed with high water level device, after pressing starting button, the inlet indicator light is on, the water supply will enter into water tank automatically, and it will heat up immediately after reaching high water level, meanwhile the indicator light is off.
- (8) It has automatic control functions:
 - If the door of sterilization room is not closed tightly and it cannot sterilize, prompting the door indicator light is off, now we can conduct drying operation.
 - If the door is opened by error in the starting process of sterilization room, the electromagnetic valve which enters into sterilization room will be closed automatically, and the door will be mechanical self-locked $\geq 0.027\text{MPa}$.
 - If starting without selecting to set sterilization time, the buzzer will be alarmed to prompt.
 - It is installed with low water level protective device, when the water level is lower than the requirement and lack of water in the entire process, it can cut off the heating power supply automatically and meanwhile, water break indicator light is on, heating and sterilization indicating is off and the buzzer is alarmed and the steam is exhausted automatically.
 - It is installed with overload leakage protective device, when it occurs electrical leakage or over-current, it can cut off the power supply automatically and the indicator light of electric appliance control panel is off.
 - It is installed with temperature controlling failure protective device, the fine-open spring safety valve is fixed on the top of sterilizer, which can open automatically and release over-pressure steam, when the steam pressure in the jacket exceeds the maximum permissible range and will close automatically when the steam pressure reduces to normal. It plays a very important role in ensuring safe application; the operation pressure range of safety valve is 0.24~0.25MPa. See Table 2.

Detailed List of Serial Number (Table 2)



S/n	Name	Specification & Model	S/n	Name	Specification & Model
1	Manual Ball Valve	DN25	4	Pressure Gauge	0-0.3MPa
2	Manual Ball Valve	DN32			
3	Check Valve	DN32			

(9) It is installed with manual emergency switch valve, when the equipment is switched off suddenly and need to open the door to fetch the objects, it is allowed to open the manual ball valve on the back of the equipment manually, releasing the pressure of sterilizer and open the door to fetch objects after pressure gauge returns to zero.

(10) It is installed with manual maintenance switch valve, when the evaporator of the equipment needs cleaning and draining, open the manual valve in the left bottom side of the equipment to exhaust the waste water from pressure box.

(11) Installed with electromagnetic valve:

- The inlet valve; press start key, the program will be closed after it is inlet water to high water level automatically.
- Drainage valve; electrify and press starting key, the programme will be opened automatically at the temperature $\leq 108^{\circ}\text{C}$ when it is exhausting air, heating and sterilizing automatically, at the temperature is $\geq 108^{\circ}\text{C}$, it will be closed automatically.
- Exhaust steam valve; electrify and press starting key, the programme will be closed after it finishes, exhausting air and it inlets water to high water level. When sterilization is completed and press emergency stop key, the programme exhausts steam and open automatically.
- Sterilization valve; electrify and press starting key, the program inlets steam automatically; when water inlet reaches to the high water level, the door is closed tightly, vice versa, the door is opened.

7. Installation and Commissioning

- (1) Put shock pad under the two rotation legs, rotate the support leg after universal wheels leave the ground, put shock pad under the oriented wheel.
- (2) It shall leave some space all around when installing the sterilizer, convenient to operate and maintain; outline dimension of maximum limit is 200×93×182cm, after the steam door is opened.



- (3) Adjust the inner drum level of the equipment through regulating the height of rotating support leg.
- (4) Connect the pipeline of drainage, water inlet and water source to the related ones of the equipment (see Fig. 3), and meanwhile configurate power source according to the requirements.

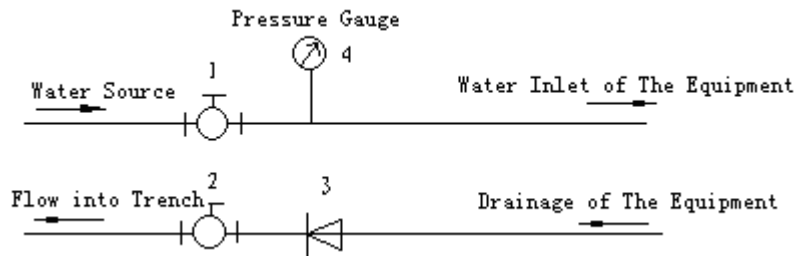

Fig.3

- (5) After installing the equipment, inspect the equipment completely once again, after confirmation without fault, it can start trial run. Refer to operation method, open the manual water inlet valve, observe the state of water source pressure gauge and examine whether the pressure is in the required pressure range. Switch on power supply and operate trial run referring to operation method.
- (6) It has been inspected by rising temperature before the products leave factory, but after it is installed and ready, the user shall perform trail run according to user' manual; if there is any problem, please inquire the reasons and solve it, it can't be put into operation until it runs normally.

8. Application Method

(1) Operation Method of the Door

Because the device is a pressure vessel, it is important to operate the door exactly, please read the following items carefully before operating the door.

A. Close the door

Before closing the door, make sure there are no cracks, damage and dirt on the sealing material of the door and make sure there is no damage and dirt on the contact face between the main body and the sealing material of the door damage and dirt.

First turn the handle counterclockwise to limit position when closing the door, so as to make all the radiation bars of the door in contraction position. Then get the door close to the main body, turn the handle clockwise, at the



beginning, turn a bit, after the door indicator light gives out signal, continue to turn the handle for 1/4-1/2 cycle. Strictly prohibit rotating the door counterclockwise after the door is closed.

B. Open the door

The door can be opened only when the inner drum pressure is equal to the ambient atmospheric pressure.

Note: The temperature of the door body is higher when sterilizing; prohibited to touch to avoid being burned.

Warning sign:  caution to be scalded!

① It must confirm the following items before opening the door:

- The stroke is in preparation or exhaust steam is finished or drying is finished.
- Inner pressure displays "0"MPa.
- It is in normal operation and the buzzer has alarmed.
- The self-lock device of the door is relieved.

Warning sign: The steam is not exhausted, please do not open the cover

② Turn the handle counterclockwise

- Turn to limit position counterclockwise to have the radiation bar contracted completely.
- Take notice if it can not rotate counterclockwise, please check whether the self-lock on handle seat has been relieved.

③ Open the door

- When exhaust steam is finished, open the door, a great deal of steam will let out, pay attention not to be scalded, please open the door a moment later.

④ About door lock structure

- According to the stipulation of pressure vessel safety performance by the country, the device is set with safety interlock, the door will be self-locked when the inner chamber pressure exceeds 0.027MPa, and it can not be opened at the time.

(2) Proper Method for Inletting Sterilization Objects

① Pay attention to the uniformity of sterilization

- The package of sterilization articles needs to be small and be inlet in loosen space.
- Package dimension of textile sterilization shall be less than 50×30×30 (cm), the weight does not exceed 5Kg.



Do not put the bottle covered tightly and disinfectant solution in the vessel.

Warning If to operate improperly, the bottle will explode, the liquid attachment will damage the inner surface of drum body and door.

② When sterilizing the injection syringe, don't put injection syringe and cast parts together directly to sterilize, it needs single package or fixed package, otherwise:

- Castings of injection syringe influences drying effect
- Unused products will be polluted during application period after germicidal treatment.
- It is easy to mix for using used products and unused products after sterilization
- Cover of castings is easy to attach water drops.

③ When using retort pouch, it is suggested to inquire the factory for its performance whether it has heat resisting property and air permeability.

④ Please do not put moisture sterilization articles in it so as to easily dry.

(3) Parameter Setting Method

① The equipment program is optional and set freely, it is supposed as follows:

- Replacement time: 0~60 minutes.
- Sterilization time: 0~99 minutes.
- Drying time: 0~99 minutes.
- Sterilization temperature: 105~134°C (it is generally 115°C~134°C in actual).

② Programming Method is shown as follows:

- Instruction of Parameter Definition
- Sterilization temperature: The lower limit temperature for control and timing during sterilization;
- Replacement time: The time for inletting steam and removing freezing air from inner chamber;
- Sterilization time: Time for timing in sterilization process;
- Drying time: Time for drying stroke timing (excluding the exhaust steam time in drying stroke);

Examples:

Example for Setting Parameter

1. Turn on the power supply, it displays 8888 8888 8888 on display panel nixie tube, all the indicator lights are on, after control system initialization is finished, it displays interlayer temperature, sterilization room temperature and



number 0 in turn.

2. Press setting key, it displays temperature numeral value needed to be set on the nixie tube, displaying sterilization temperature, the displayed value is the numeral value that is set last time. The numeral value flashes by 1S frequency. Meanwhile the sterilization indicator light is on, meaning it is setting sterilization temperature.

Press ▲ key, the nixie tube will stop flashing when the set sterilization temperature value increases by the way of plus 1. The upper limit value of the set sterilization temperature is 134°C, and go on to press ▲ key, the value is kept at 134°C.

Press ▼ key, the nixie tube will stop flashing when the set sterilization temperature value decreases by the way of minus 1. There is no lower limit value for setting sterilization temperature, it decreases to 115°C, return to 134°C and decreases circularly.

Press ▲ key for a long time, the nixie tube will stop flashing when the set sterilization temperature value increases quickly and continuously by the way of plus 1.

Press ▼ key for a long time, the nixie tube will stop flashing when the set sterilization temperature value decreases quickly and continuously by the way of minus 1.

If not to press ▲ key or ▼ key for 10S, the nixie tube will recover to flash. Now the set sterilization temperature is not saved.

3. Press setting key again, the nixie tube which displays the value 0 displays the replacement time value needed to be set, the displayed value is the one set last time. The value is flashing by 1S frequency (if the previous sterilization parameter is still in setting state and not flashing, the value will be flashing 10S later). Meanwhile the sterilization indicator light is off, which means it is setting replacement time.

Press ▲ key, the nixie tube will stop flashing when the set replacement time value increases by the way of plus 1. Set the upper limit value of replacement time for 60min, go on to press ▲ key, the value is kept at 60min.

Press ▼ key, the nixie tube will stop flashing when the set replacement time value decreases by the way of minus 1. There is no lower limit value for setting replacement time, it decreases to 0, return to 60 min and decreases circularly.

Press ▲ key for a long time, the nixie tube will stop flashing when the set replacement time increases quickly and continuously by the way of plus 1.

Press ▼ key for a long time, the nixie tube will stop flashing when the set replacement time value decreases quickly and continuously by the way of minus 1.



If not to press ▲key or ▼ key for 10S, the nixie tube will recover to flash. Now the set replacement time is not saved.

4. Press setting key for a third time, the nixie tube which displays the value 0 displays the sterilization time value needed to be set, and the displayed value is the one set last time. The value is flashing by 1S frequency (if the previous sterilization parameter is still in setting state and not flashing, the value will be flashing 10S later). Meanwhile the sterilization indicator light is on, which means setting the sterilization time.

Press ▲key, the nixie tube will stop flashing when the set sterilization time value increase by the way of plus 1. The upper limit value of setting sterilization time is 99min, go on to press▲key; the value is kept at 99min.

Press ▼key; the nixie tube will stop flashing when the set sterilization time value decreases by the way of minus 1. There is no lower limit value for setting sterilization time, it decreases to 0, then return to 99min, it decreases circularly.

Press ▲key for a long time, the nixie tube will stop flashing when the set sterilization time value increases quickly and continuously by the way of plus 1.

Press ▼key for a long time, the nixie tube will stop flashing when the set sterilization time value decreases quickly and continuously by the way of minus 1.

If not to press▲key or ▼key for 10S, the nixie tube will recover to flash. Now the set sterilization time is not saved.

5. Press setting key for a fourth time, the nixie tube which displays the value 0 displays the drying time value needs to be set, the displayed value is the one set last time. The value is flashing by 1S frequency (if the previous sterilization parameter is still in setting state and not flashing, the value will be flashing 10S later). Meanwhile the drying indicator light is on, which means setting the drying time.

Press ▲key, the nixie tube will stop flashing when the set drying time value increases by the way of plus 1. The upper limit value of setting drying time is 99min, go on to press ▲key, the value is kept at 99min.

Press ▼key, the nixie tube will stop flashing when the set drying time value decreases by the way of minus 1. There is lower limit value for the set drying time, it decreases to 0, then return to 99min, it decreases circularly.

Press ▲key for a long time, the nixie tube will stop flashing when the set drying time value increases quickly and continuously by the way of plus 1.

Press ▼key for a long time, the nixie tube will stop flashing when the set drying time value decreases quickly and continuously by the way of minus 1.



If to press ▲key or ▼key for 10S, the nixie tube will recover to flash. Now the set drying time is not saved.

6. Press setting key for a fifth time, nixie recovers the display when turning on the power supply and meanwhile save the set parameters.

Time Clock Setting

The control system consists of real-time clock, the clock mainly provides the time parameter which is in accordance with the local time for printer, after the arrival of equipment, users shall adjust time parameter according to the practical situation, the detailed adjusting method is as follows.

Press starting key and turn on power supply switch, then a voice of “Di” from buzzer can be heard. It displays 8888 8888 8888 on nixie tube of the panel from left to right in correct order, all indicator lights are on, after 10S, the nixie tube displays time, they are: year (e.g. 08 year), month (e.g. 04 month), day (e.g. 20 days), hour (e.g. 12 hours), minute (e.g. 00 minute), second (e.g. 00 second) in turn.

1) Press starting key for the first time, the value of year is flashing, presses ▲key or ▼key to adjust the value of year. If not to press ▲key or ▼key, the value will be flashing 10S later.

2) Press starting key for the second time, the value of month is flashing, press ▲key or ▼key to adjust the value of month. If not to press ▲key or ▼key, the value will be flashing 10S later.

3) Press starting key for the third time, the value of day is flashing, press ▲key or ▼key to adjust the value of day. If not to press ▲key or ▼key, the value will be flashing 10S later.

4) Press starting key for the fourth time, the value of hour is flashing, press ▲key or ▼key to adjust the value of hour. If not to press ▲key or ▼key, the value will be flashing 10S later.

5) Press starting key for the fifth time, the value of minute is flashing, press ▲key or ▼key to adjust the value of minute. If not to press ▲key or ▼key, the value will be flashing 10S later.

6) Press starting key for the sixth time, the value of second is flashing, press ▲key or ▼key to adjust the value of second. If not to press ▲key or ▼key, the value will be flashing 10S later.

After adjusting parameters, the parameters will be saved automatically.

Turn off the power supply and the clock parameter adjustment is finished.

Adjust the clock parameters every six months to make sure the time exact.

(4) Instruction of Sterilization Sequence

Preparation Stroke

In preparation procedure, it mainly finishes: load the sterilized articles, turn on the water source switch, check



whether the water source pressure complies with the requirement and close the door of sterilization room.

Electrify and plug the attaching plug in power supply socket, turn on the breaker switch and the power supply switch of control system. It displays 8888 8888 8888 on the nixie tube of display panel, all indicator lights are on, after the control system initiation, the nixie displays jacket temperature and sterilization room temperature 0, the slow exhaust steam light and fast exhaust steam light of indicator light are on, then set working parameters (if necessary). The setting range can refer to sterilization reference table for various kinds of articles (see Table 3) and comply with different sterilization articles to set sterilization temperature/sterilization time.

Sterilization Reference Table for Various Kinds of Articles (Table 3)

Category of Sterilization Articles	Sterilization Time min	Steam Pressure MPa	Steam Relative Temperature °C
Category of Rubber	15	0.1~0.11	121
Category of Dressing	10	0.215	134
Category of Vessel	8	0.215	134
Category of Equipment	8	0.215	134
Category of Bottling Solution	30	0.08	115

Curve Diagram for Working Procedure

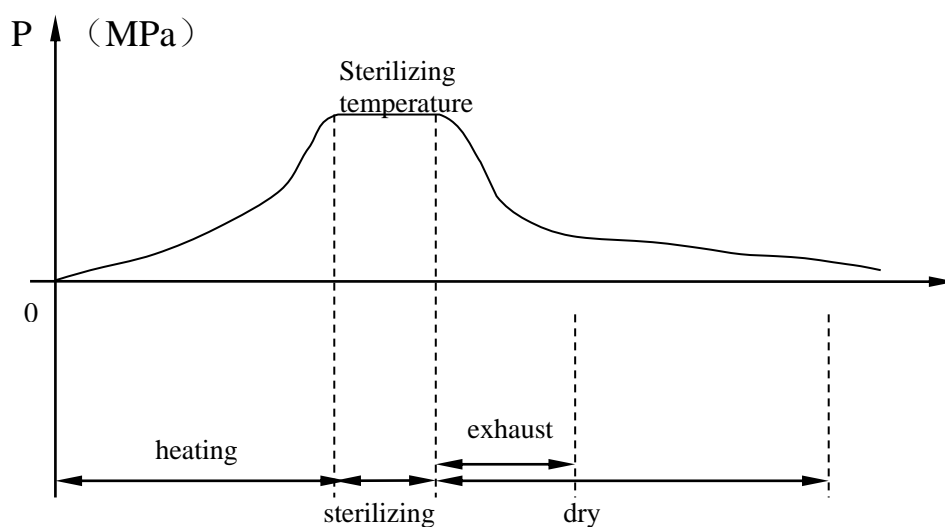

Curve Diagram for Setting Working Procedure (Taking parameters for example)



Temperature Rise Stroke

Press starting key, after entering temperature rise stroke, both the door light and starting light are on, if the water level is in the lower level inside the generator, the water break light and inlet light are on, the water is fed inside steam generator. Meanwhile slow exhaust steam and fast exhaust steam lights are on, fast exhaust steam valve, slow exhaust steam valve and inlet valve are opened.

When the water level reaches the high water level, steam valve and inlet valve will be closed and inlet indicator light is off. The electric heating pipe starts to heat and the heating indicator light is on.

The temperature in the steam generator starts to rise.

When heating to the set sterilization temperature $+0.5^{\circ}\text{C}$, inlet valve and fast exhaust steam valve will be opened to do gravity replacement. Remove freezing air of the sterilization room. Fast exhaust steam indicator light is on.

The nixie tube displays jacket temperature, sterilization room temperature and replacement time. The replacement time is decreasing.

When the replacement time reduces to 0, the fast exhaust steam valve will be closed and the inner chamber will continue to heat up. The fast exhaust steam valve indicator light is off.

Start pulsating movement of fast exhaust steam valve to drainage before not reaching sterilization temperature.

The nixie tube displays jacket temperature, sterilization temperature and sterilization time in correct order.

Enter sterilization stroke when reaching the set sterilization temperature.

Sterilization Stroke

After entering sterilization stroke and reaching the sterilization temperature, it will start to sterilize and timing.

During the stroke, stop timing when the temperature is lower than the set temperature. Close the inlet valve when the temperature is 1°C higher than sterilization temperature, inspect the delay exhaust steam automatically when the temperature is 3°C higher than sterilization temperature.

The nixie tube displays jacket temperature, sterilization temperature and sterilization time decreasing in correct order.

The pulsation of slow exhaust valve is opened to drainage.

When the sterilization time is over, it will enter drying stroke.

Drying Stroke

Enter the drying stroke and remove the steam out of inner chamber, when the temperature in the sterilization room



is lower than 105°C, the buzzer will alarm to remind the users to open the door for drying. Pay attention to the pressure of sterilization room and open the door for drying.

Now the nixie tube displays jacket temperature, sterilization temperature and drying time decreasing in correct order.

When the drying time reduces to 0, the entire sterilization period is finished (Note, if to set the drying time to be 0, The exhausting steam and directly buzzing of the buzzer will be transferred to finish).

Finish Stroke

When the buzzer buzzes, take out the sterilization articles.

Note: As for sterilized fluid, pay attention to not opening the door directly, but turn the door in place, open the door to 5 mm and take out the articles, until the liquid temperature of the inner chamber reduces below 50 °C.

Warning After entering working state, please do not try to open the door.

9 Attentions in Use

Precautions prior to use

A. Horizontal pressure steam sterilizer is an equipment, which takes advantage of saturated steam to sterilize the dressing packages and various medical appliances. Please pay attention to the following:

- (1) Sterilization articles of this device are the ones with the characteristics of high temperature resistance and high humidity resistance.
- (2) Sterilization articles of this device shall be washed prior to use. Otherwise, the dirt attached will affect the sterilization effect.
- (3) Under normal circumstances, it is different from the drying degree of the sterilization articles.

B. Security

Since the device belongs to Class I pressure vessel, please confirm the responsible person in order to ensure the proper and safe way to use this device.

C. Horizontal pressure steam sterilizer in normal use will produce sound pressure ≤ 85 dB, please be relaxed to use.

Daily use and maintenance

Warning Since the device is Class I pressure vessel, in order to use properly and safely every day, please pay



attention to the following while repairing and maintaining.

- (1) Please refer to "Operation of the door" when opening the door, and check whether the sealing materials of the door have been cracked and damaged.
- (2) Please refer to "Repair and Maintenance" for sealing material of door.
- (3) Please be careful not to be burnt when adding or taking out the sterilization articles.
- (4) Please confirm the indications of the pressure gauges during the use of this device. Be sure to cut off power supply and check the control system when the pressure exceeds 0.25 MPa.
- (5) Please check whether the inner chamber and exhaust steam port has sundries before use every day. If there are sundries piled up on the filter net, it will cause incomplete or bad sterilization.
- (6) Please be sure to maintain the performance of device, please self-check at regular time.

10. Maintenance and Repair

Please refer to this chapter for the maintenance of the equipment

Warning Do not reconstruct the equipment.

Replacement method of sealing materials

- Sealing materials of the door are the main parts to seal between the door and drum body. It must be checked regularly and have timely replacement when finding breakages.
- Get the right size and complete sealing materials prepared.
- Take out the aging or damaged sealing materials with wooden tools.
- Wipe off the sundries on the sealing materials of the installed door with an alcohol-attached wipes and insert new materials.
- Press the sealing material tightly with wooden tools; close the door 1 / 2 circle after the door switch is in working process.
- Test the machine; Shut the door tightly (No steam leakage occurs when sterilization).
- Inspect every part of the door comprehensively.

Replacement for Interlocking Apparatus Sealing Element of the Door

- Open the door and disassemble round copper cover or stainless steel cover.
- Remove the old cup packer and clean the installing position with wipes.



- Replace new parts.
- Test the machine (No steam leakage in the position of the door handle during sterilization)

Filling up Grease Lubricant to the Door Mechanism

Door mechanism is the part needed to be opened and closed frequently, it is always under high temperature, so it needs to fill up grease lubricant regularly (it is usually about 2 months), and the method of filling up grease lubricant is as follows:

Preparation Parts:

- Prepare No.4 high-temperature grease (ZBE36009—88) ZN6—4
- Gauze glove
- Wipes
- Necessary tools

Order of filling up grease lubricant is as follows:

- Disassemble the ball-end part of fixed radiation bar.
- Clean up the aging grease lubricant in screw thread and the ball-end part of fixed radiation bar.
- Re-install the disassembled parts in original order.
- Rotate the door several times repeatedly to have it smeared evenly.

Don't make the door rotate in the open position in order to avoid the radiation bar extending to damage the external appearance of the equipment.

Maintenance for Other Components

Safety valve: pull up the draw rod of safety valve every other month, exhaust steam several times repeatedly to avoid failure.

Pressure gauge: inspect it regularly, check every year.

Breaker: inspect it regularly, if there is any fault, please replace it in time.

The replaced fuse specification shall comply with the regulation in the user' manual and it is the same with the original fuse specification.



Make sure the grounding connection of sterilizer and electric outlet is in good state.

Common Fault and Troubleshooting

Reason Analysis and Troubleshooting	Fault
Whether the power is on Whether the circuit breaker is closed Whether the fuse wire on control panel is broken	1. The stroke indicator light is not on
Whether the switch of door is closed the corresponding indicator light is on)	2. Press “starting” and don’t enter into the heating process
Make sure the power supply (380V) is on Whether there is fault about water supply pipe Whether the water level has reached	3. Do not heat
Whether to prepare the stroke Whether it is drying or finished Whether the inner chamber pressure is 0.21MPa	4. The door can not be opened
Rotate the door handle by clockwise in place Lubrication state of the door	5. The door can not be closed tightly
Whether the outer chamber pressure is 0.22MPa Whether the inner chamber pressure is 0.22MPa Whether the state of drainage is good	6. Sterilization time is too long

During the sterilization, if it buzzer alarming appears and the nixie tube displays error message, it means there is fault in working process, the details are shown as follows:

Error 1

It means the door is not closed tightly or the door switch is off. Check the door switch or the door.

If to press the starting key without closing the door, it will display the above error message.

If to display the error message, turn on fast exhaust steam valve and slow exhaust steam valve and turn off electric heating pipe.

Error 2

It means the water level reaches to the low level inside the evaporator, check the low water level switch or whether it needs to add water.

If to display the error message, turn on fast exhaust steam valve, slow exhaust steam valve and inlet valve and turn off electric heating pipe.

At the moment, if it needs to add water, please do not open the door and cut off the power supply till the pressure in sterilization room and evaporator returns to 0, or turn off the power supply to wait the evaporator to be cool gradually then feed the water.



Error 3

It means the heating time has reached to 2 hours but the temperature inside the evaporator has not already reached to the set temperature.

If to display the error message, turn on the fast exhaust steam valve, slow exhaust steam valve and inlet valve and turn off electric heating pipe.

At the moment, it needs to check whether the power supply is in the phase-lack state and the electric heating pipe is burnt out.

11 Sign Instruction



Caution to be scalded!! Warning sign of scald

Steam in, stop opening!

Warning sign

Safety Valve

Safety valve

Exhaust

External steam exhaust port

AC220V 60Hz 3-P 9KW

Requirement of external power supply



Grounding sign

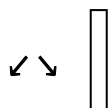

Door-Lock indication sign

12. Instruction of Circuit Breaker and Fuse Capacity

- a) With three-phase circuit breaker.
- b) The fuse is 250V/2A $\phi 5 \times 20$ mm

13 Principle Schematic Diagram of Pipeline

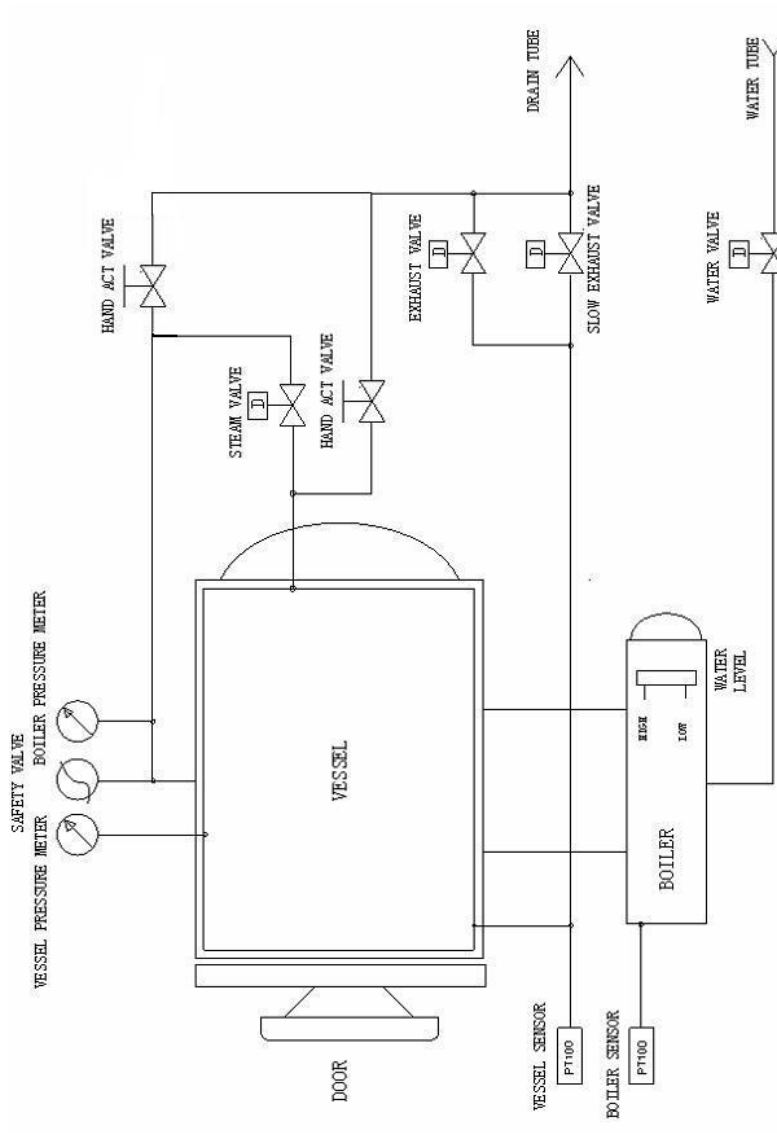

14 Electric Wiring Diagram

