

Model YR0102-4
Fume Hood Series (E)

Instruction Manual

Thank you very much for purchasing our Fume Hood model YR0102-4.

Please read the “Operating Instructions” and “Warranty” before operating this unit to assure proper operation. After reading these documents, be sure to store them securely together with the “Warranty” at a hand place for future reference.



Warning: Before operating the unit, be sure to read carefully and fully understand important warnings in the operating instructions.



OUR SERVICES

Benefits and Support

In Kalstein France, we take care of the full satisfaction of our customers, that is why we provide value-added services of the highest level based on our experience.



Online Inductions and Trainings

In any part of the world, receive your induction or training from our specialized team of engineers



Quick Response

Our work team is always available to response all your consults or questions, in order to support you in any situation.



#Letsgivemore ♥

Thanks to your purchase, a donation will be made to a non-profit foundation that fights against breast cancer and helps most vulnerable communities.



Technical Support

Enjoy of personalized advice for the correct preventive and corrective maintenance of your equipment, thanks to Kalstein's manuals and articles, special catalogues and video tutorials.



Delivery Logistics

We take care of all the necessary logistics for the dispatch of your goods, whether is by sea, land or air.



Kalstein Worldwide

With more than 25 years growing with our customers, Kalstein's multiformat and modern content, is now present in more than 10 countries and increasing.



Preface

Thank you very much for purchasing our YR (E) series Fume Hood.

Please read the “Operating Instructions” and “Warranty” before operating this unit to assure proper operation. After reading these documents, be sure to store them securely together with the “Warranty” within touch for future reference.



Warning: Before operating the unit, be sure to read carefully and fully understand important warnings in the operating instructions.

Disclaimer

Kalstein shall not be liable for any equipment failure or damage, or for any direct or indirect damage that may occur during the use of the equipment.

1. Malfunction or damage due to violation of the instructions, precautions, and intended use of this manual.
2. Malfunction or damage caused by repair or alteration of the other company.
3. Malfunction or damage caused by use instruments of other company at the same time.
4. Malfunction or damage caused by operating environment not corresponding to the specified operating environment (power conditions, installation environment, etc.).
5. Malfunction or damage caused by natural disasters such as earthquakes and floods.
6. Malfunction or damage caused by the company unaware of the movement or transfer (transport) after installation.



Content

1. Unpacking, Installation and Debugging.....	4
1.1 Unpacking of Main Body.....	4
1.2 Unpacking of Base Cabinet.....	6
1.3 Accessories Checking	7
1.4 Environment requirements.....	8
1.5 Installation	8
1.6 Inspection after Installation	11
2. User Instructions	13
2.1 Functions.....	13
2.1.1 Product concept.....	13
2.1.2 Operating principle/air flow pattern	13
2.1.3 Protected object.....	14
2.1.4 Technical parameters.....	14
2.2 Product Structure	15
2.2.1 Structural composition of YR (E)Series Fume Hood	15
2.2.2 Structure introduction	16
2.3 Instructions of Operation.....	18
2.3.1 Normal Operation Notice	18
2.3.2 Normal Operation Process.....	19
2.4 Regular Maintenance.....	19
2.4.1 Clean the equipment surface.....	20
2.4.2 Storage conditions.....	20
2.5 Replacement Parts List.....	20
2.6 Wiring Diagram.....	22



3. Common Failures and Solutions	23
3.1 Trouble shooting.....	23
3.1.1 Replace	
the fuse	24
3.1.2 Replace	
fluorescent light	24
3.2 Label Description.....	25
3.2.1 Fuse label	
25	
4. Warranty	27



1. Unpacking, Installation and Debugging

Please firstly check whether the packing box is in good condition. If the packing box is damaged, please take photos and contact the freight carrier. Kalstein and its dealers are not responsible for shipping damages

1.1 Unpacking of Main Body

Choose a proper unpacking method according to the actual situation.

1.1.1. For wooden box

a) Necessary tools for unpacking: M8 wrench



Picture 1

b) Method 2 Necessary tools for unpacking: Electric drill with hexagon dead M8



Picture 2

Quick unpacking procedures (Picture 3). Remove the screws shown in the diagram below, then move the wooden pieces to right and left.

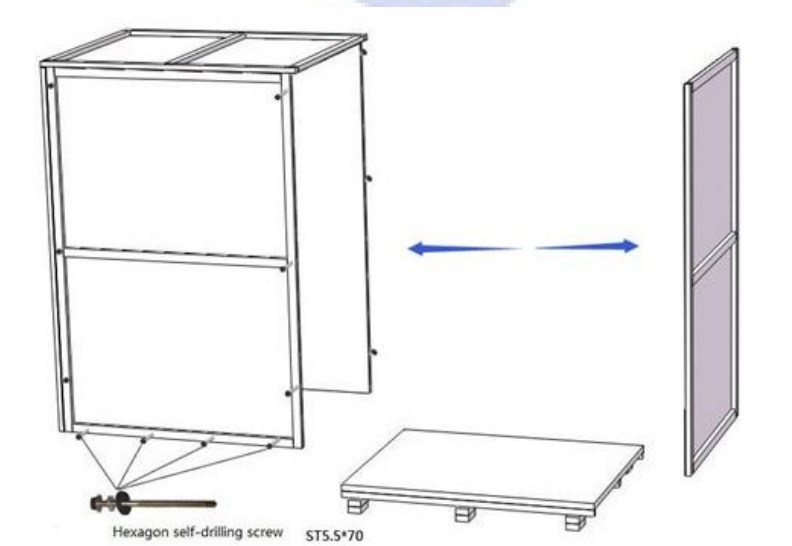

Picture 3

1.1.2. For carton box

Use scissor to cut the packing tape, take off the package cover, then move up the boxbody.

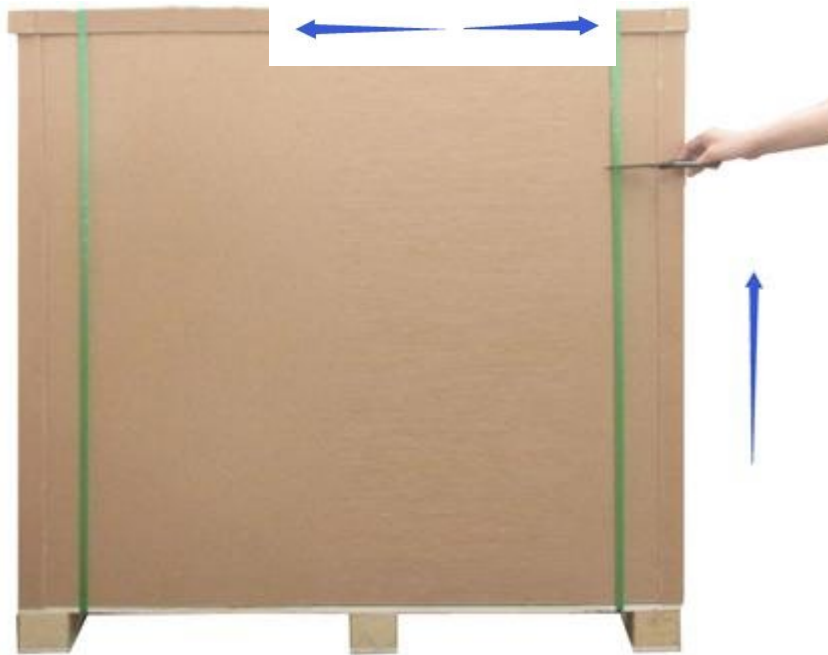

Picture 4

1.2 Unpacking of Base Cabinet

Choose a proper unpacking method according to the actual situation.

1.2.1 For wooden box

Please refer to the main body unpacking method (of wooden box) in the previous pages, use M8 electric drill or M8 wrench to remove the screws and unpack the box.

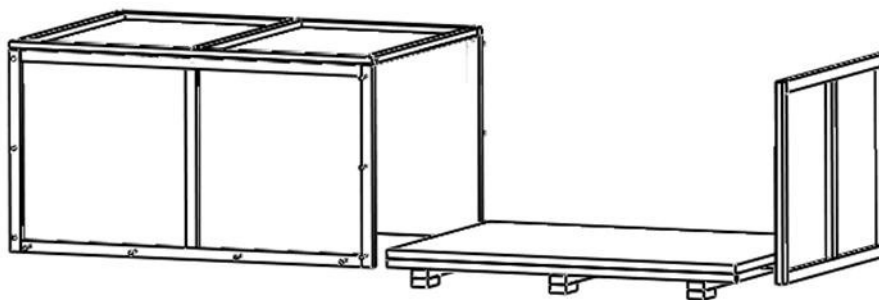

Picture 5

1.2.2 For cartoon box

Please refer to the main body unpacking method (of carton box) in the previous pages, use scissor to cut the packing tape, take off the package cover and move up the box body.



Picture 6

1.3 Accessories Checking

Main body box:

No.	Items	Quantity
1	Main body	1 unit
2	User manual	1 pc
3	Certification of quality	1 pc
4	Inspection report	1 pc
5	Fuse (5A)	1 pc
6	Fuse (10A)	1 pc
7	Stainless steel hexagon socket head cap screw M10×20 Stainless steel hexagon nut M10 Stainless steel flat washer 10 and spring washer 10	4 sets



8	PP water sink with accessories	1 set
9	Water tap	1 pc
10	Gas tap(optional)	1 pc
11	power cable	1 pc
12	Allen wrench	1 pc

Base cabinet box:

No.	Items	Quantity
1	Base stand	1 unit
2	Exhaust duct	1 pc
3	Duct clamp	2 pc

1.4 Environment requirements

- a) Only applicable to indoor operation
- b) Environment temperature: 15°C~35°C
- c) Relative humidity: ≤75%
- d) Pressure range: 70 kPa~106 kPa

Electrical requirements

- a) Electrical parameters: consistent with the rated voltage and rated frequency of the Fume Hood (See 2.1.4 Technical parameters)

Power supplies need to be grounded (Judging method: test the live wire and the neutral wire of the main socket with multimeter. The voltage between live and ground should equal to the voltage of local electrical grid, and the voltage between neutral wire and ground should be zero, otherwise the power grounding is bad)

1.5 Installation

- A. Remove all the package
- B. Check the surface of the base cabinet and the main body to make sure there is no scratch and deformation

- C. Check the items according to the packing list of instruction
- D. Keep the equipment close to the installation place
- E. Make sure the voltage frequency is the same as the required power supply on the label.
- F. Press a row buckles on one side of the cabinet, remove the middle panel from both sides.

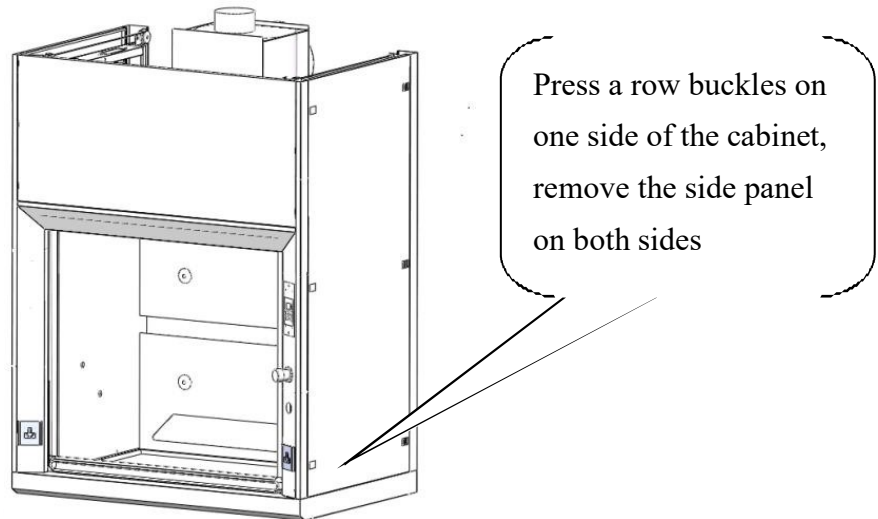

Picture 7

Connect base cabinet with main body

- a) Put the base cabinet in an appropriate location, open the caster wheel brake, place main body on the base cabinet. Make sure each side is in alignment.
- b) Make sure the main body and base cabinet are stable enough to prevent sideslip. Open the doors of the base cabinet and take out the components from the accessory bag

Stainless steel hexagon socket head cap screw M10×20

Stainless steel hexagon nut M10

Stainless steel flat washer 10 and spring washer 10hex nutsM10

As shown in figure 8, connect the base cabinet with the main body and tighten them, then put the middle panel on the original position.

Insert the hexagon socket head capscrews (M10×20) into the holes at the bottom of the main body (refer to the Picture 9). These screws should pass through the main body and the base

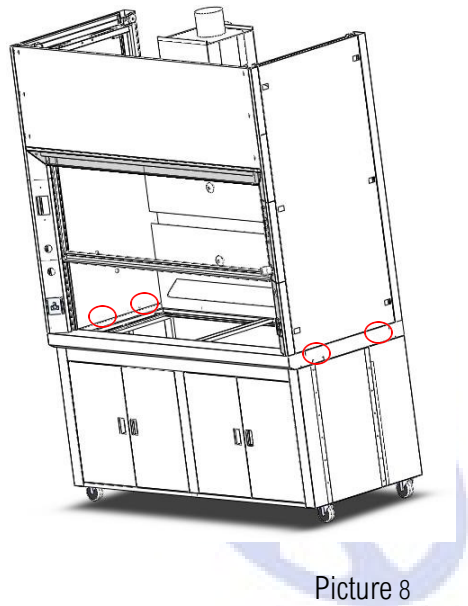

Picture 8

- c) Installed water tank corresponding mounting holes on the panel, then connect sink pipe in the base cabinet (water tank connected to the sewage pipe has been completed in factory) with laboratory sewage pipe; If equipped with water tap, gas tap, connect their pipes with lab pipe.
- d) As shown in figure 9, take pipe clamp and the outside pipe, put pipe clamp on the outside pipe, then put the outside pipe on the cabinet outlet, and finally fasten pipe clamp with a screwdriver, connect the other side of the outside pipe to outdoor.

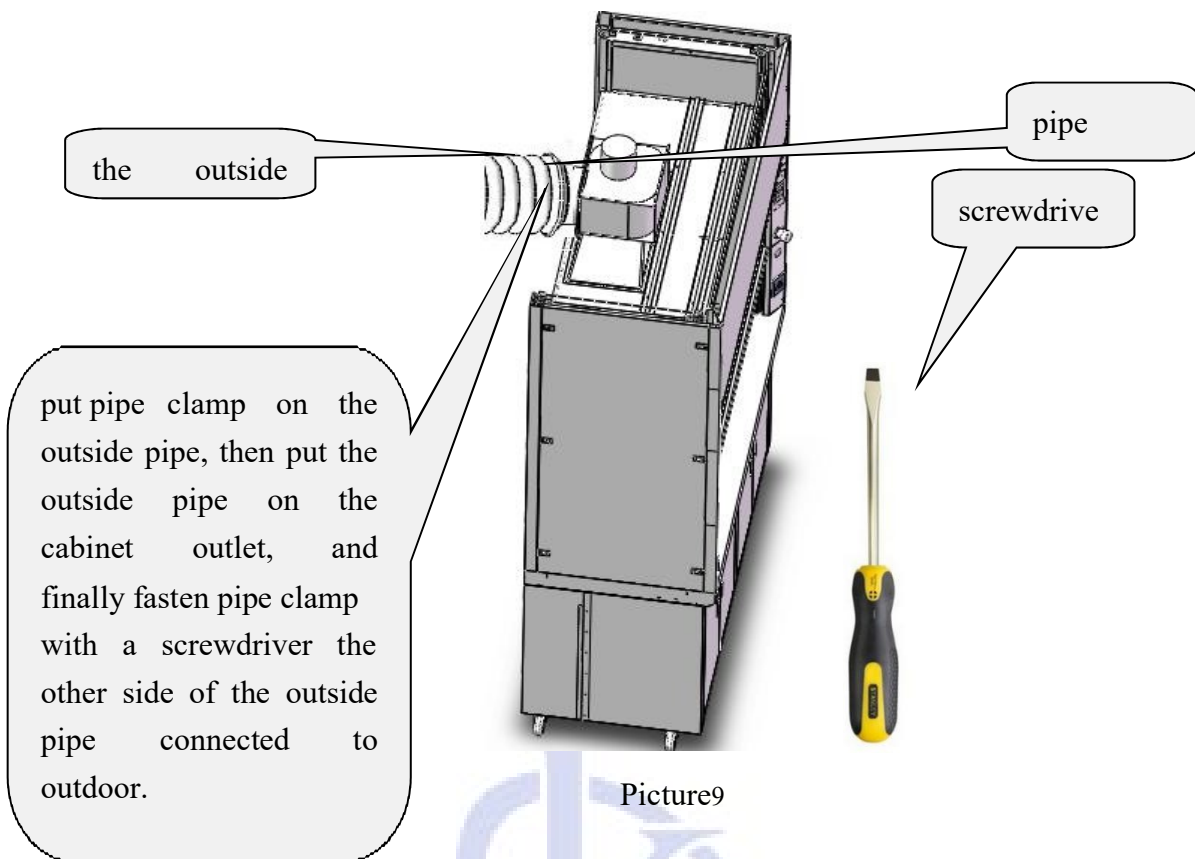

1.6 Inspection after Installation

Refer to this table and follow the instruction in 2.3.2, check the following items after powering on the Fume Hood.

Checking Items	Normal working status
Power status	Equipment could be powered on/switched off when press the power button
Fan	Runs normally after pressing the fan button, speed could be adjusted by pressing the adjusting button
Front window	Front window could be moved smoothly by pressing the UP and DOWN buttons
Fluorescent lamp	Lamp lights up after pressing button
Socket	Use multimeter to test voltage output after pressing the socket button

 **NOTE:** Please contact Kalstein technical department or agent for inspection or trouble shooting when problems could not be solved. Methodology of trouble shooting is stated in the After-sale Service Manual.

2. User Instructions

2.1 Functions

2.1.1 Product concept

There will be variety of toxic gasses, aerosol and corrosive substance during the experimental operation in the chemical laboratory, in order to protect the operator and laboratory environment also to prevent contaminants in the experiment spread to the laboratory. Fume hood should be used near the sources of pollution

 **NOTE:** Experiments with the use of flammable, explosive substances and strong acids or bases should NOT be conducted by this YR (E) II series Fume Hood.

2.1.2 Operating principle/air flow pattern

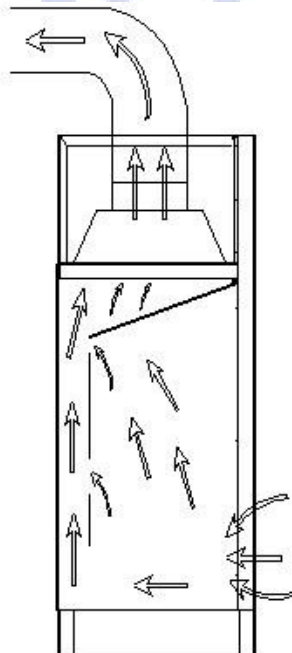

Picture 10

2.1.3 Protected object

The primary goal of the Fume Hood is to protect operators and laboratory environment from exposure to infectious aerosol and toxic gas which may be generated from the reaction during experiments.

2.1.4 Technical parameters

Model Parameter	YR0102-4) □	YR0103-6□	YR0104-6 □	YR0105-6 □
Rated Voltage AC	220V±10% □		110V±10% □	
Rated Frequency	50 Hz □		60Hz □	
External Dimension (W*D*H))	1000*800*2515 mm	1200*800*2515 mm	1500*800*2515 mm	1800*800*2515 mm
Working Zone Dimension (W*D*H)	790*600*870 mm	990*600*870 mm	1290*600*870 mm	1590*600*870 mm
Power Supply Consumption	400 W	400 W	500 W	500 W
Inflow Velocity	0.3~0.8m/s			
Fluorescent Lamp Consumption	T5 8W	T5 12W	T5 16W	T5 16W
Noise	≤68dB (A)			



NOTE:

- a) Power supply consumption does not include the consumption loaded at working zone, which should not exceed 500W.
- b) Kalstein reserves the right to make changes in future product design, without reservation and without notification to its users.

2.2 Product Structure

2.2.1 Structural composition of YR (E)Series Fume Hood

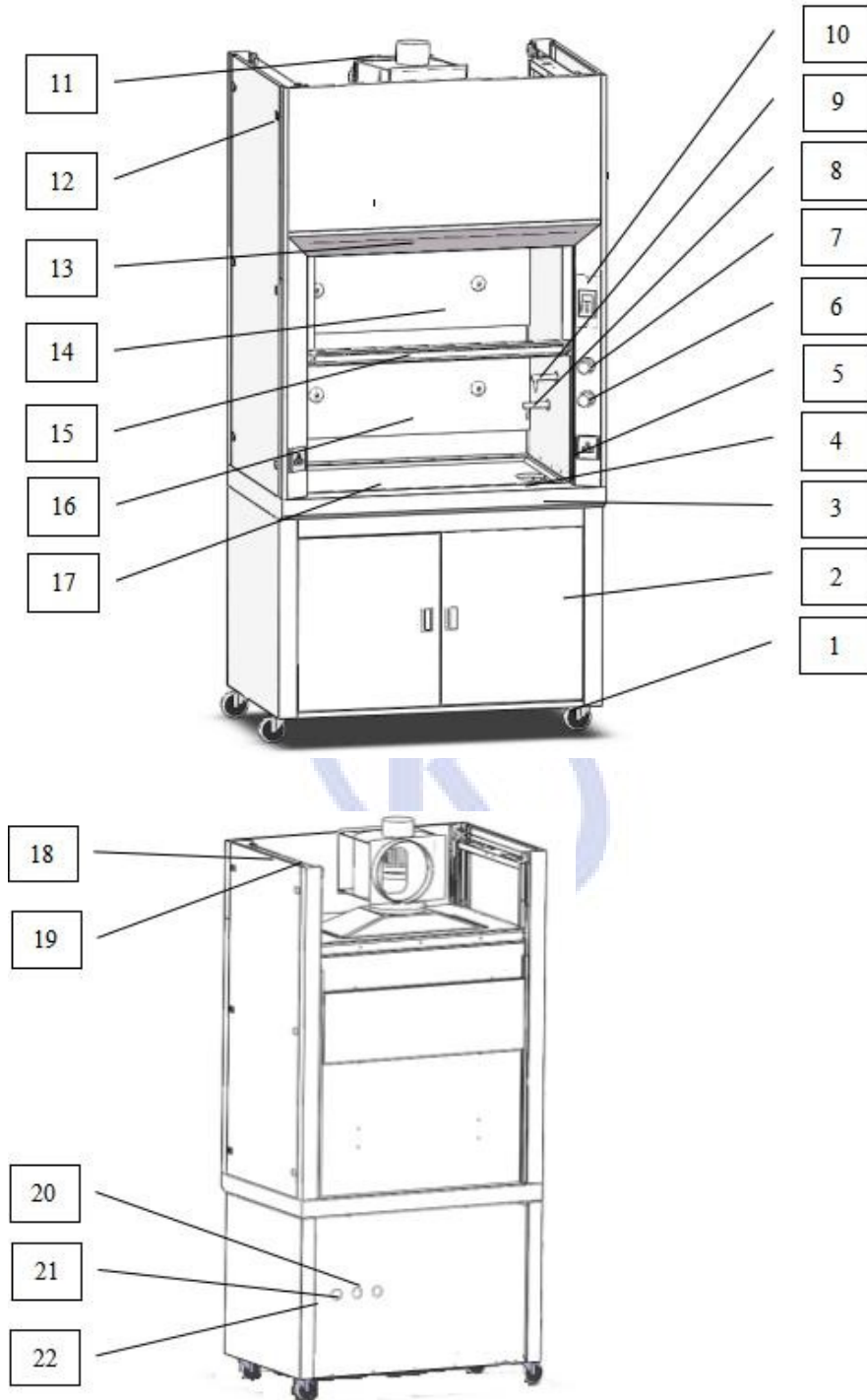

Picture 11

1, Caster

13, Fluorescent Lamp

- | | |
|----------------------------|-----------------------------------|
| 2, Base cabinet | 14, Front window |
| 3, Armrest | 15, Glass door shake hands handle |
| 4, Water sinks | 16, Phenolic compact laminate |
| 5, Socket | 17, Worktable |
| 6, Gas tap control knob | 18, Socket insurance tube |
| 7, Water taps control knob | 19, Power stock |
| 8, Gas tap | 20, Water outlet |
| 9, Water taps | 21, Gas inlet |
| 10, Control panel | 22, Water inlet |
| 11, Exhaust outlet | |
| 12, Buckles | |

2.2.2 Structure introduction

★Lighting source

LED fluorescent lamp to ensure that the operating zone average illumination meets the standard requirements.

★Control panel

The equipment operation panel, socket, lighting, fan, fan control, power six touch buttons and windshield display unit, each function working lamp.

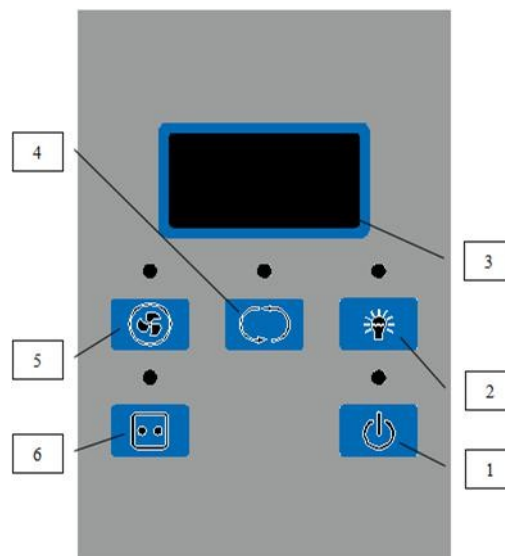

Picture12

Soft touch buttons

The main operation can be operated through the touch buttons.

Power button:  the main switch of the Fume Hood

Blower (Fan):  the control button which show blower working status

Adjust fan speed:  press to adjust the speed of the blower (fan) from F1 to F9, When the F9, press again return to F1.

Fan gear adjustment every time to save the current value, which is in the same working stall as the last time when turn off the blower.

Fluorescent lamp:  Fluorescent lamp control keys

Socket power:  General controls the working state of power socket

★Socket

The socket is set in the front side of the cabinet, can supply power to the equipment in the operation zone.

 : Please make sure the total power of sockets should be $\leq 500W$

★Insurance tube(fuse)

Insurance tube is installed on the top of the right side of the cabinet (picture 11), power socket, socket insurance tube used on the fume hood respectively equipped with fire wire and socket insurance tube. Insurance tube specifications should be consistent with the insurance tube label contents. Replace please refer to label content for replacement.

★Structure

a) Fume hood shell with 1.0 mm cold rolled steel plate after antirust processing, electrostatic spraying.

b) Interior: High grade melamine board with good acid and alkali resistance function, workable Chemical resistant phenolic resin, can remove facilitate cleaning.

front window: 5mm toughened glass

- d) Control panel: soft touch buttons, machine good appearance, easy to operate.
- e) Electric control system: Prevent overload, prevent to get an electric shock and stable performance and long service life.
- f) Stock: Using special laboratory safety products, fire retardant material of PC materials.

2.3 Instructions of Operation







2.3.1 Normal Operation Notice

- a) Make sure input voltage is correct and stable. The rated load of main power socket should be higher than cabinet consumption. Plug must be well grounded.
- b) The equipment should be powered off and unplugged before doing any replacement of parts, such as UV lamp and fluorescent lamp.
- c) The front window is made of explosion-proof toughened glass. In order to keep the front window clean and clear, please wipe it by wet soft cloth and keep it away from hydrofluoric acid
- d) The air deflector and other internal accessories should be cleaned according to the use of the Fume Hood
- e) The air duct and the blower of the Fume Hood should be cleaned and maintained regularly in a proper way
- f) Fume Hood should be placed in a position where there should be no other equipment or machine within 150mm of the front window
- g) Do NOT place any soft or tiny materials (such as soft tissue) on the work table during the operation to prevent breakdown of the blower caused by sucking those materials
- h) The packed Fume Hood should be stored in a warehouse with relative humidity no more than 75% and temperature lower than 40°C. The warehouse should have good ventilation performance without acid, alkali or other corrosive gases
- i) The maximum storage period is one year. A performance inspection should be done if the storage period exceeds one year



NOTE: KALSTEIN WILL NOT BE LIABLE FOR ANY RISK OR DAMAGE ARISING FROM YOUR FAILURE TO APPROPRIATELY OPERATION THE FUME HOOD!

2.3.2 Normal Operation Process

- a. Connect to a suitable power supply, the LED screen would be lighted as 
- b. Press the POWER button  on the control panel. The LED screen would display the operating time of the blower. Raise the front window to a proper height. Press the FAN button  to turn on the blower. The LED screen would display the speed level of the fan memorized from the last time of operation. The indicator light on the FAN button would be turned on to show the working status of the blower. Make sure the blower runs at least FIVE minutes before starting any experiment.
- c. Press the LAMP button  to turn on the fluorescent light. The indicator light above the button would be turned on to show the working status of the fluorescent light. Press the LAMP button  again, to turn off the fluorescent light. Please refer to the actual condition of illumination in the laboratory room to decide whether the fluorescent light is needed.
- d. Press the POWER button  on the control panel, then power off the Fume Hood.
- e. After finishing the experiment, turn off the blower and the fluorescent light and drop the front window to lowest.
- f. If power failure happened during the operation causing by interruption of electricity supply or dropping off of plug or other abnormal situations, the equipment could memorize the current operating status automatically and resume those functions when power on again.

2.4 Regular Maintenance

Overall maintenance period

Comprehensive maintenance is recommended to be carried out for a period of 1000 working hours or one year; weekly and monthly maintenance is also required to optimize the performance of the Fume Hood.



Turn off ALL power before applying maintenance for the equipment!

The accumulated operating time is a vital factor of deciding when the maintenance is needed. A comprehensive record of operation is highly recommended to be taken down after each time of operating. The blower and the exhaust duct should be inspected and maintained regularly.

Maintenance methods

1) Weekly and monthly maintenance

- a. Clean the external surface and front window (refer to 2.4.1)
- b. Check the various functions of the Fume Hood
- c. Record down the maintenance result

2) Annual maintenance

- a. Check the rope firmness of the front glass window
- b. Check the fluorescent lamp, replace it if needed
- c. Apply for overall performance test of the cabinet annually to ensure that the safety performance has met the requirements. User is responsible for testing costs
- d. Record down the maintenance result

2.4.1 Clean the equipment surface

Clean the fume hood regularly (at least every week). Wipe the entire surface with a wringed out soft cotton cloth which has been soaked with concentrated liquid soap. Don't spray any chemicals on the operation panel or other labels, to prevent discoloration or illegibility of the label film. Use a piece of soft cotton cloth or towel with non-abrasive household cleanser to wipe the external surface and front window.

2.4.2 Storage conditions

Fume Hood should be stored in a warehouse with relative humidity no more than 75% and temperature lower than 40°C. The warehouse should have good ventilation performance without acid, alkali or other corrosive gases. Storage period shall not exceed one year. Fume Hood stored for more than one year needs to be unpacked and checked before selling and using. Only the tested and qualified safety cabinet could be sold.

2.5 Replacement Parts List

YR0102-4 Fume Hood Replacement Part List

NO.	Part Name	Specification
01	Fuse tube	5A\10A
02	LED Fluorescent lamp holder	T5 8W
03	Blower	PP Centrifugal fan
04	Main control panel	YR(E) series fume hood main control



		panel
05	Front window glass	756*950*5

YR0103-6 Fume Hood Replacement Part List

NO.	Part Name	Specification
01	Fuse tube	5A\10A
02	LED Fluorescent lamp holder	T5 12W
03	Blower	PP Centrifugal fan
04	Main control panel	YR(E) series fume hood main control
05	Front window glass	956*950*5

YR0104-6 Fume Hood Replacement Part List

NO.	Part Name	Specification
01	Fuse tube	5A\10A
02	LED Fluorescent lamp holder	T5 16W
03	Blower	PP Centrifugal fan
04	Main control panel	YR(E) series fume hood main control
05	Front window glass	1256*950*5

YR0105-6 Fume Hood Replacement Part List

NO.	Part Name	Specification
01	Fuse tube	5A\10A
02	LED Fluorescent lamp holder	T5 16W
03	Blower	PP Centrifugal fan
04	Main control panel	YR(E) series fume hood main control
05	Front window glass	1556*950*5

2.6 Wiring Diagram

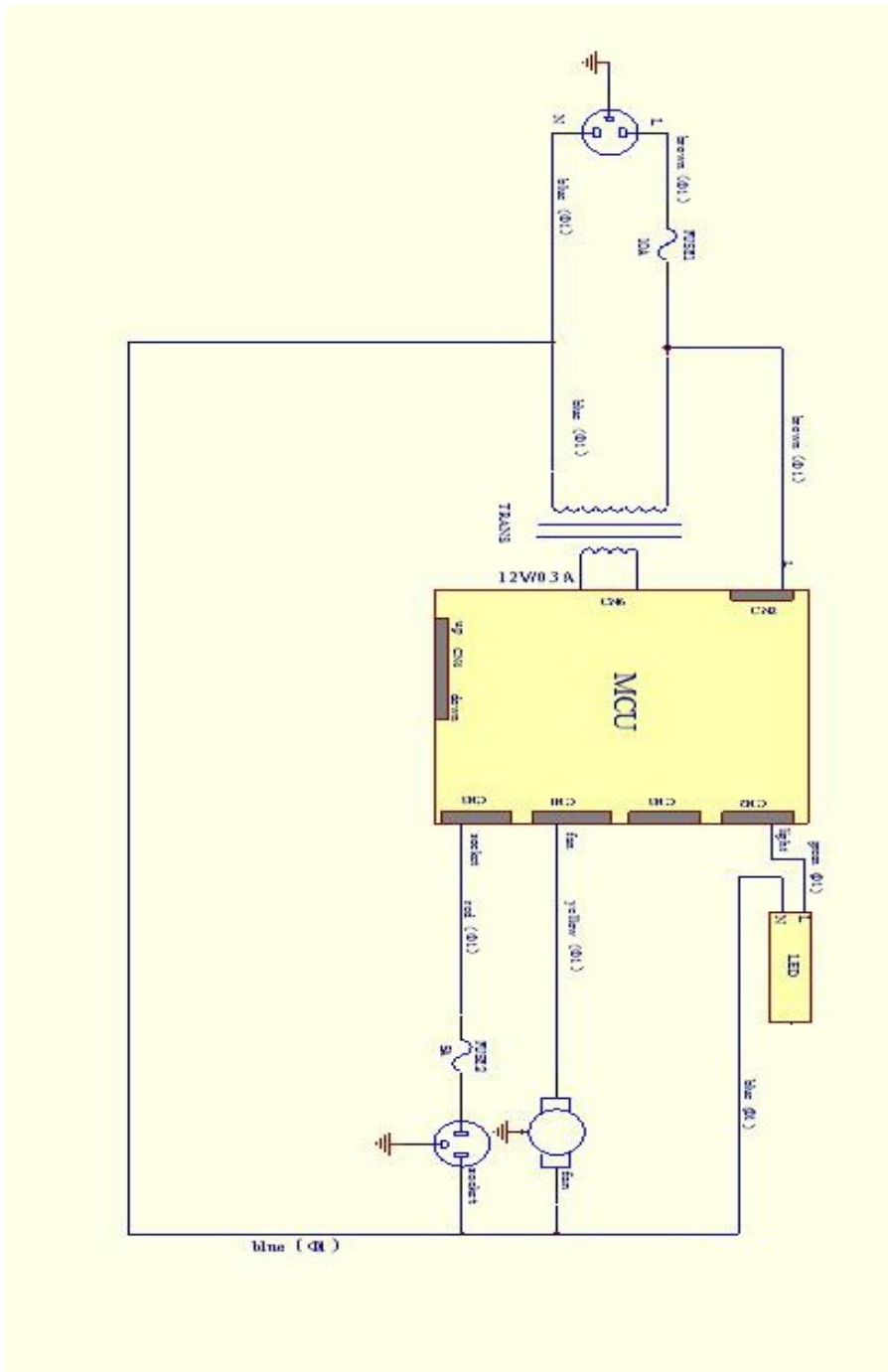

Picture 13

3. Common Failures and Solutions

3.1 Trouble shooting

Please confirm that the power is well connected, whether the power cord is obvious damaged, the circuit and the fuses are in good condition.

1. In order to ensure the maintenance and use of security, you need check whether the equipment has a reliable grounding measures according to the manual. To check whether the electrical wiring of the equipment is off, broken and short circuit. It should be excluded if similar situation appears.

Common Failures diagnosis and Solutions

Failures	Checking Part	Suggestion
LED fail to work	Lamp tube	Replace the lamp tube
	Circuit	Check the circuit
	Control panel	Replace the control panel
Button fail to work	Control panel	Make sure the power is well connected and the fuse is in good condition
		Check if the button is broken
		Make sure the connecting wire is well connected
		Replace the control panel
Blowers fail to work	Blower	Replace the blower if it is defective
	Circuit	Check the circuit
	Control panel	Replace the control panel
No electricity in socket	Socket fuse	Check if the socket fuse is broken
	Socket	Check if the socket is broken
	Circuit	Check the circuit
	Control panel	Replace the control panel
No electricity in equipment	Power supply	Check whether the power supply is well connected
	Power cord	Check whether the power cord is in good condition

	Fuse	Check if the fuse is damaged
	Potential transformer	Check whether the transformer works normally
	Control panel	Replace the circuit panel
Display fails to work	Connecting cable	Check whether the connecting cable is wellconnected
	Display screen	Check whether the screen is in good condition
	Control panel	Replace the circuit panel

Simple accessories replacement method

3.1.1 Replace the fuse

The roundness fuse holder on the top of the fume hood confirmed by label, it is F5A $\phi 5 \times 20$ mm F10A $\phi 5 \times 20$ mm. For replacing the fuse, turn off the power and disconnect the plug. Use a Phillips screwdriver and rotate it anticlockwise to unscrew the fuse holder. Replace the fuse inside the fuse holder and then, use a Phillips screwdriver and rotate it clockwise to screw back the fuse holder. Use a Slotted screwdriver to lever up the fuse holder to open it. Replace the fuse inside the fuse holder and then, press the fuse holder back.

Use a Slotted screwdriver to lever up the fuse holder to open and replace it, then press the fuse holder back.



Picture 14

Use a Phillips screwdriver and rotate it anticlockwise to unscrew the fuse holder. Replace the fuse inside the fuse holder and then, use a Phillips screwdriver and rotate it clockwise to screw back the fuse holder.

3.1.2 Replace fluorescent light

For replacing the lamp tube, turn off the power and disconnect the plug. Remove the lampshade on the top of the fume hood with the Phillips screwdriver, then you can see the fluorescent light. Strike the power cord of the lamp tube, remove the used fluorescent light. Install a new lamp tube by

pushing it in and connecting with the power cord.



Remove the used fluorescent light. Install a new lamp tube by pushing it in and connecting with the power cord.

Picture 15

⚠️ NOTE: a) The above trouble shooting methods should be done by qualified electricians under safe conditions (cut off power supply). Other components should not be removed. Risk caused by failing to follow those instructions would be responsible by user.

b) Please contact local dealers if a failure could not be traced or solved. Do NOT repair the equipment without a qualified electrician.

c) The trouble shooting and repair of this equipment only could be undertaken by trained and recognized technicians.

d) Please contact local dealer or agent to order required component or part. The model number and the serial number of purchased Fume Hood need to be indicated.

3.2 Label Description

3.2.1 Fuse label

Tubular Fuse For
Socket
F5AL250V

F10AL250V

Picture 16

Note: 5A socket fuse label located under the socket fuse holder.

10A power fuse label, located under the power socket.

Ground label (Picture 17)



Picture 17





4.Warranty

- 4.1. Warranty is 12 months from EX-factory date (excluding consumable accessories, UV and Fluorescent lamp, fuse)
- 4.2. Kalstein would not be responsible for any repair of damage caused by improper operation
- 4.3. If the warranty has been expired, Kalstein would still be responsible for repair with relative charges.
- 4.4. Kalstein would provide equipment drawings and necessary technical data for maintenance companies or personnel trained by Kalstein engineers



Warranty Declaration:

One-year Warranty, Life-long Maintenance



All rights reserved © KALSTEIN France S. A. S.,
Optimum Business Center 450 Rue Baden Powell,
• 34000 Montpellier, France.
Tlf: +33 467158849 / +33 680760710/ +33 663810023
<https://kalstein.eu>
KALSTEIN FRANCE, S. A. S

