

Analytical Balance  
YR01767  
**Operation User's Manual**

Thank you very much for purchasing our Analytical Balance YR01767.

Please read the "Operating Instructions" and "Warranty" before operating this unit to assure proper operation. After reading these documents, be sure to store them securely together with the "Warranty" at a hand place for future reference.



**Warning:** Before operating the unit, be sure to read carefully and fully understand important warnings in the operating instructions.



OUR SERVICES

## Benefits and Support

In Kalstein France, we take care of the full satisfaction of our customers, that is why we provide value-added services of the highest level based on our experience.



### Online Inductions and Trainings

In any part of the world, receive your induction or training from our specialized team of engineers



### Quick Response

Our work team is always available to response all your consults or questions, in order to support you in any situation.

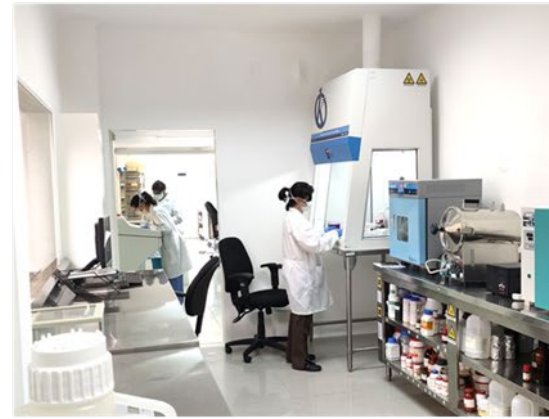

### #Letsgivemore

Thanks to your purchase, a donation will be made to a non-profit foundation that fights against breast cancer and helps most vulnerable communities.



### Technical Support

Enjoy of personalized advice for the correct preventive and corrective maintenance of your equipment, thanks to Kalstein's manuals and articles, special catalogues and video tutorials.



### Delivery Logistics

We take care of all the necessary logistics for the dispatch of your goods, whether is by sea, land or air.



### Kalstein Worldwide

With more than 25 years growing with our customers, Kalstein's multiformat and modern content, is now present in more than 10 countries and increasing.





# CONTENT

<i>Warning and Safety use Instruction.....</i>	<i>1</i>
<i>Overview.....</i>	<i>2</i>
<i>Basic weighing operation. ....</i>	<i>5</i>
<i>Basic weighting function.....</i>	<i>5</i>
<i>Calibrate/Adjust .....</i>	<i>6</i>
<i>Application Function.....</i>	<i>7</i>
<i>Counting Function. ....</i>	<i>7</i>
<i>Percentage Weigh Function.....</i>	<i>8</i>
<i>Density Weigh Function.....</i>	<i>10</i>
<i>Operation Menu .....</i>	<i>15</i>
<i>Communication Parameters. ....</i>	<i>16</i>
<i>Unit Conversion ..</i>	<i>17</i>
<i>Technical Specification... ..</i>	<i>19</i>
<i>Repairing and Maintenance .</i>	<i>19</i>





## *Warning and Safety use Instruction*

### Safety

- To avoid damage of the balance , please read the operation manual carefully before use .
- ☆ Please do not use it in dangerous environment .
- ☆ Please cut off the electricity without use for more than one week .
- ☆ Please power off the balance when it connects with output device or before cut off the connection .
- ☆ Magnet or static interference will affect the accuracy of balance , when these interference removed, balance will recover to normal use .

### Spare Parts

- ※ The spare parts we used are the most compatible with the balance .

Any revision to the balance or use the third party's cable and other device , it's end user's responsibility to check and correct the power and voltage .

- ※ Please do not open the out case , if the safety label is damaged , no warranty will be offered .

## *Overview*

These series electronic balance was designed and developed by our company. Utilized the advanced microcomputer controlled technology and high precision sensor technology (magnetic balance) , it is the ideal device for fast accurate weighing , widely used in medical research institute、 schools 、 enterprise 、 road construction and defense department etc.

- ▶ LCD backlight display, easy and clear ;
- ▶ Operator-friendly ,direct weigh ,directly read the weighing result ; □
- ▶ Highly smart , tare and back to zero within the whole weighing scope , overload display .
- ▶ Multi-mode choice : counting 、 percentage weigh 、 density weigh .
- ▶ With RS-232C interface, easy to connect with printer、 computer and other output device .



Part I: Open the package



☆ Once open the package , please check any visible damage on the balance .

☆ Please keep all the packing material until successful installation , to avoid any balance return . When pack the balance , please remove all the cables to avoid any unnecessary damage .

#### Part II、 Packing list

- balance
- operation manual
- scale
- power adapter
- weights (≤500g)
- Conformity certificate
- warranty card

#### Part III、 Remarks

- ◇ Forbid to get wet in the rain or washed by water ;
- ◇ Forbid to put balance in the place where is too hot or too wet , with vibration 、 corrosion 、 strong magnet or with the risk of explosion;
- ◇ Cockroach and other little creature are forbidden to live inside balance;
- ◇ Forbid to be bumped or heavily pressed (not over the max capacity),when use the pan forbidden to be dashed ;
- ◇ If the balance not used for a long time , please clean it up ,pack it by plastic bag with drier in ;
- ◇ Please pre-heat for 60 minutes before balance was used to raise the precision .

#### Part IV. Preparation before Use

Put the balance in a level position before use. Use the level adjust feet under the front place to adjust the level until the bubble move to the center of the circle.

Put the balance on the stable and flat table , not on the shaking or vibrating plate , to make the balance stable .  
(Recommend to use aseismic marble)

Avoid to put balance in the place with big temperature change or air flow , such as the place with direct sunlight or cold air outlet .

Please use the separate power socket to avoid the interruption by other device .

Please do not put anything on the scale when power on the balance.

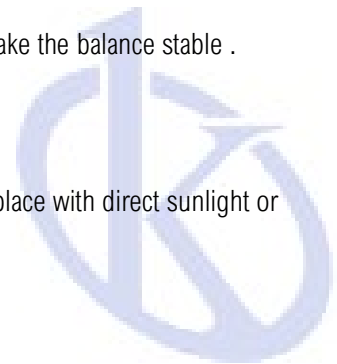



※ Make the balance adjust itself to the change of temperature

When change the balance from lower temperature to higher temperature or reverse , please put the balance in the new environment for about 2 hours , then pre-heat the balance , make it conform with the new temperature.

### Part V. Out looking and Installation Adjustment

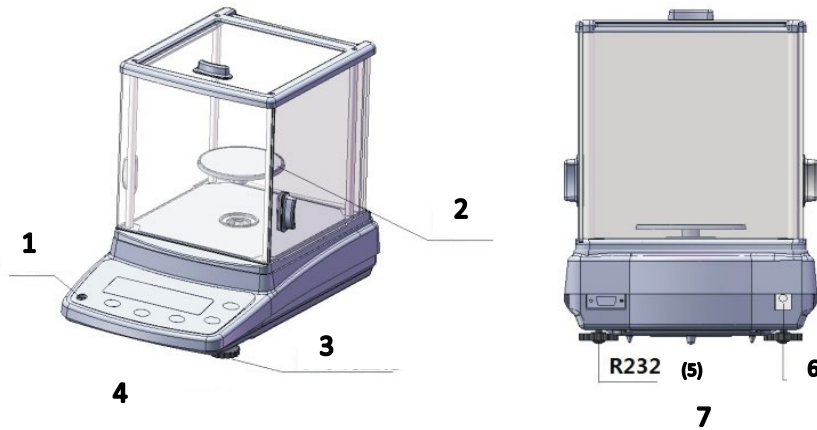

1: Level sensor , 2 : Pan , 3 : Level adjust wheel

4 : Front view

RS232 (5) : RS232 interface, 6 : power socket

7 : Back view

### Part VI. Display panel



1 : Switch off mark    4 : number display area

2 : sign display        6 : unit display area

3 : stable mark        5 : All displayed info by screen





Part VII. Instruction for Button

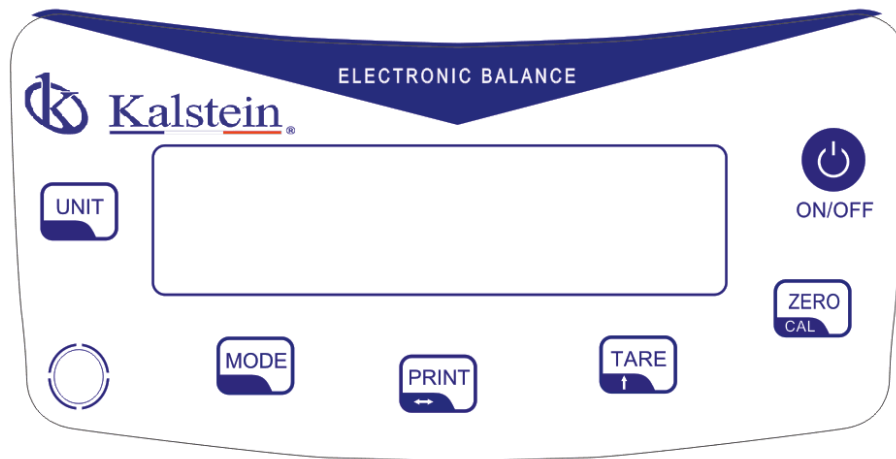

Button	Name	Function
ON/OFF	ON/OFF	Short press : Switch on/off the balance .
Zero/Cal	Zero/Cal	Short press : When it $\leq 6$ gram ,back to zero ; Long press : enter calibration within 5 seconds
Tare	Tare	Short press : Tare ; Go to next step menu, number scroll;
Print	Print	Short press : data output, change the position when set the numbers ;
Mode	Mode	Long press : mode exchange, weigh\count\percentage...
Unit	Unit	Short press : unit conversion Long press : 1d/10d conversion

## Basic Weigh Operation

### Basic Weigh Function

#### Preparation

- ✧ Connect the power supply: when the panel display [**\*** ] , press button [ON/OFF] to switch on the balance





### Pre-heat Time

【In order to ensure the precision of weighing , please preheat the balance completely reference to technical parameter form (page 19-20) , then start the following operation .】

### Example

Basic weigh operation (balance already pre-heated) , we take 210g/0.0001g balance as an example .

button (command)	steps	panel display
	1. Zero position stable	0.0000 g
	2. Put the container on the balance (e.g. 50g )	50.0000 g
【TARE】	3. Tare the balance	0.0000 g
	4. Put the sample in the container (e.g.100g)	100.0000 g

### Calibration/Adjustment

Only do the Calibration/Adjustment in the following case :

【In order to ensure the precision of weighing , please preheat the balance completely before do calibration】

※ No load on the balance , balance already tared , inner weigh signal stable .  
If the above conditions not fulfilled , it will display error message .

If the above conditions fulfilled , it will display calibrate the scale value you need .

### Outside Calibration

button (command)	steps	panel display
short press[ZERO]	1.Balance goes to Zero position	0.0000 g
long press [CAL]	2. About 5 seconds	CAL
	Release 【CAL】	-----
	The scale value twinkles for 3 sec.	[[ 200.0000 ]]

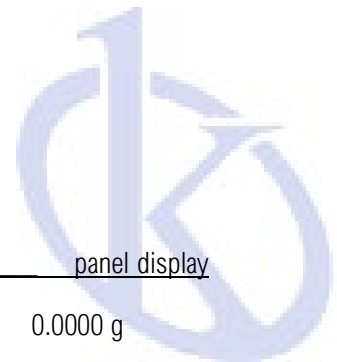





3、 Put on the indicated scale.

Display the calibrated scale value after 5 sec.

200.0000 g

4. Take off the scale, complete calibration.

0.0000 g

### Application Function Operation

Choose the Mode :

button (command)	steps	panel display
Long press [MODE]	Enter the choice for mode	
	Normal weigh mode	NORMAL g
	Count mode	COUNT pcs
	Percent weigh mode	PERCENT %
	Density measure mode*	DENSITY d

\*Density measure mode is an option , if you need please contact our company or authorized distributor .

Long press the button [MODE] , all the modes will display on the screen in a cycle , when the mode you want display on the screen , release the button [MODE] to confirm the balance work mode .

### Counting Mode

#### **Aim**

By this procedure the user weigh the total weight of the certain samples which with similar single weight, then divided by the single sample weight to get the final quantity of the sample.

#### Example

button (command)	steps	screen display
long press [MODE]	Enter the choice of mode	
	Choose : COUNT mode	COUNT pcs
	When release, the radix number value twinkling	[[20]] pcs
press [TARE]	optional radix number value 10、 20.....1000	

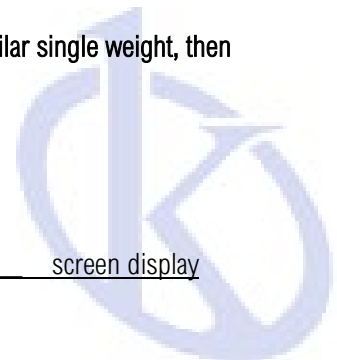



※ End user can set the radix number alone , press button [PRINT] to change the position , press [TARE] to scroll the number .  
Put on the certain number of sample,

Put all on the pan to set a radix number (In this e.g. we use 20 pcs)

press [CAL] To confirm the sample radix number 20 pcs

Remove the samples 0 pcs

Weigh the unknown numbers (in this e.g.200pcs) 200 pcs

※ In Count Mode , if you want to reset the radix number value, please press [MODE] to reenter the Count Mode .

Exit the Count Mode : Long press [MODE] , choose the normal weigh mode NORMALg

### Percent Weigh Mode

The end user can make a certain weight as definition 100% , then make other weight displayed as the percent of the definition weight .

button (command)	steps	Panel display
long press [MODE]	Enter the choice of mode	
	choose : percent weigh	PERCENT %
	When release, twinkling	[[-000001 ] %
Press [TARE]	Choose the precision of percent	
	Put on the chosen percent sample	[ [ 100.00 ] %
	(e.g.100.00%)	
press [CAL]	confirm sample 100%	100.00 %
	Take off the sample	0.00 %
	Weigh the unknown percent sample	58.00 %
	(e.g. 58.00%)	
※ In percent weigh mode , if you want to reset the percent precision and radix percent value , please press button [MODE] to reset .		
Exit percent weigh mode : long press [MODE] , choose the normal weigh mode NORMALg		

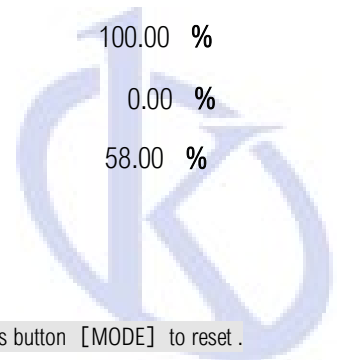



## Density Mode

### Aim

By using this procedure user can measure the density value for solid or liquid so that judge the sample desirable or not .(need to buy the necessary weighing kits from our company )

### Weighing method for solid

Step 1 : Use the density measure device to measure the solid density in the air ;

Step 2 : Put the solid into a certain liquid to measure the density.(The density of the certain liquid must be known in advance)

button (command)	steps	panel display
------------------	-------	---------------

Long press [MODE] Enter the choice of mode

1. Choose density mode .

DENSITY d

Solid density

[SOLID] d

Short press [CAL] 2. Confirm the solid density measure mode

Enter the liquid temperature coefficient settings 01.00000 d

※ The user can set the liquid temperature coefficient value on his own , please refer to Form1.

Press [PRINT] to change the position, press [TARE] to scroll down the number , press [CAL] to confirm , enter the solid density measure situation .

3、 The balance reminding to weigh in the air

[HI] 0.0000 g

4、 Put the sample and weigh it in the air

[HI]

(e.g. : The quality of the sample in the air is 6.8135g)

6.8135 g

button (command)	steps	panel display
------------------	-------	---------------

short press [CAL ] 5. To record the current weigh value in the air

[LO]

and indicating solid weighed in liquid

6.8135 g

6. Take off the solid

[LO]

It indicating solid weighed in liquid

0.0000 g

7. Put the solid in liquid

[LO]

(e.g. Quality of the solid is 1.3518g in liquid)

1.3518 g

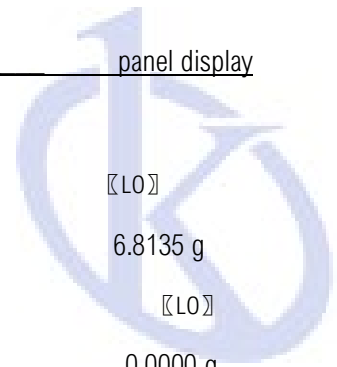



---

Short press [CAL] 8. It records the weigh value in liquid OK

In the meantime calculate the solid density 1.2398 g<sup>d</sup>

Measure result : 1.2398 g/cm<sup>3</sup>

※ If you want to measure different solid's density , please repeat step 4-8 .

※ In the solid density measure mode , if you want to reset the liquid density coefficient, please press [MODE] , to re-enter the coefficient settings .

Exit the density mode : Long press [MODE] and choose the normal weigh mode **NORMALg**

Appendix I. Pure water temperature and density cross reference.

T/°C	g/cm3	T/°C	g/cm3	T/°C	g/cm3
0	0.99986	14	0.99927	28	0.99626
1	0.99993	15	0.99913	29	0.99597
2	0.99997	16	0.99897	30	0.99567
3	0.99999	17	0.99880	31	0.99537
4	1.00000	18	0.99862	32	0.99505
5	0.99999	19	0.99843	33	0.99473
6	0.99997	20	0.99823	34	0.99439
7	0.99993	21	0.99802	35	0.99405
8	0.99988	22	0.99780	36	0.99369
9	0.99981	23	0.99756	37	0.99333
10	0.99973	24	0.99732	38	0.99297
11	0.99963	25	0.99707	39	0.99259
12	0.99953	26	0.99681	40	0.99221
13	0.99941	27	0.99654		



**The weigh method for liquid density**



Use density measure device , the volume of planed standard sample must be known .

The user need to enter the volume of standard sample manually . The latest data entered will be stored for further use .

Step 1 : To measure the liquid density , please weigh the standard sample in the air ;

Step 2 : Then weigh the standard sample in the liquid want to be measured.

button (command)	steps	panel display
------------------	-------	---------------

long press [MODE] Enter the choice of mode

1. Enter the density mode DENSITY d

2、 Release, solid density [SOLID] d

Short press [TARE] 3、 Choose liquid density [LIQUID] d

Short press [CAL] 4、 Confirm to enter liquid density measure

Enter "Gravity hammer volume" settings. 05.4957 d

※User can set the gravity hammer volume on his own, the gravity hammer volume of this balance :

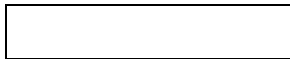

press [PRINT] to change the position , press [TARE] to scroll down the number, press [CAL] to enter the situation for liquid density measurement .

5.It indicating gravity hammer weighed in the air [HI]  
0.0000 g

6. Weigh the gravity hammer in the air. [HI]  
(e.g.: The quality of gravity hammer is 6.8135g in the air) 6.8135

Short press [CAL] 7. It records the value weighed in the air [LO]

And indicating gravity hammer measured in liquid 6.8135 g

8、 Take off the weighed sample [LO]  
It indicates gravity hammer measured in liquid 0.0000 g

9. Weigh the gravity hammer in liquid [LO]  
(e.g.: The quality of gravity hammer is 1.3518g in liquid) 1.3518 g

Short press [CAL] 10、 It records the weigh value in liquid OK

In the meantime calculate the weighed liquid density 00.99707 g<sup>d</sup>

※ If you want to measure different liquid's density , please repeat step 5-10 .

※ In the liquid density measure mode , if you want to reset volume of gravity hammer , please press [MODE] , to re-enter the gravity hammer volume settings .

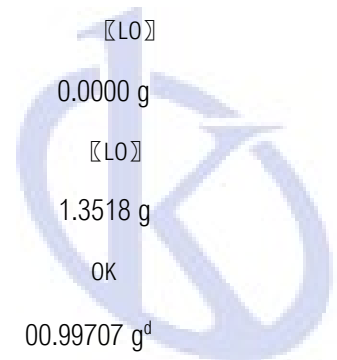



Exit the density mode : Long press [MODE] and choose the normal weigh mode NORMALg

### The Balance Operation Menu

Switch on, enter the weigh condition; press [TARE] + [ZERO] at the same time,

in 3 seconds it displays Cod0000

Press [PRINT] to change the position , press [TARE] to scroll the numbers or choose the parameters , press [ZERO] to confirm and enter the next step .

Code	Mark display	Description	Setting range
Cod0001	Zero-x.x	Zero range	0.0d-6.0d
	Stdy-x.x	Start sensitive range	0.0d-6.0d
	Sens--X	Inner sensitivity grade	1,2,3,4,5,6
	Filt-X	Filter radix	1,2,3,4,5,6,7 ; 1 weakest, 7strongest
	Speed	Weighing speed	1, 2, 3 ; 3 fastest
	BL-xxx	LCD back light mode	ON, OFF, AUT
	BEPxxx	Beeper switch	ON,OFF
	MOdRec	Whether record the weigh mode	0 : Always goes to normal weigh mode when switch on; 1 : record the weigh mode last used before switch off , enter this mode directly when switch on .
	TAdj	Display temperature correction	-1.9 to +1.9
	Baudxx	Baud rate	12 : 1200 ; 24 : 2400 ; 48 : 4800 ; 96 : 9600
Con---xxx	Communication method	Non : No communication ; CON: continuous ; Sty : communicate when stable ; Key : communication when press [print] ; SOFT : software exchange ; Txxx : communicate by time , xxx is the set time , unit is second.	
BLANK	Output the blank line	Line 0,1,2,3,4,5,6,7,8,9	
Cod0002	Unit---xxx	ON : display ; OFF : close	Unit shielding choice, "Unit"means the unit displayed by 8 codes , at the same time the directly displayed unit will be lighten . The shielded unit will not display when weighing .

### Communication Parameters

Baud(baud rate )

12 : 1200bps ; 24 : 2400bps ; 48 : 4800bps ; 96 : 9600bps ;

1、COM (Communication Method )

NON : No communication ; CON : continuous communication ;

STY : Communicate when stable ; KEY : Communicate when press button [PRINT] ; SOFT : software exchange ; Txxx : Communicate in every certain set time .

3、Communication data layout sample (in six lines , easy for mini-printer ) ;

MODE:NORMAL Mode





TEMP:31.8C      Temperature  
STATUS:STEADY      Current status  
STEP:NONE      Current step  
WT:0.00g      Weight value  
SIGN:      Sign by the operator  
                 Blank

4、 The list of command which the communicating device can send in software exchange mode. (ASCII code)

No.	Command	Function
1	?	Sample
2	P	Print
3	T	Tare
4	Z	Back to Zero
5	U	Unit

**Unit Conversion List**

Mark	Unit	Conversion radix
g	gram	1
ct	Carat	5
oz	Ounce	0.03527396200
ozt	Troy weight ounce	0.03215074700
dwt	Penny weight	0.64301493100
GN	grain	15.43235835000
lb	pound	0.00220462260
N	Newton	0.00980654189
dr	Dram	0.56438222222
tlT	Taiwan tael	0.02666666000
tlS	Singapore tael	0.02645544638
tlH	Hong Kong tael	0.02671725000
T	tola	0.08573532418
mom	momme(Japan pearl)	0.26670000000
kg	Kilo gram	0.00100000000



mg	Micro gram	1000.00000000
----	------------	---------------

### Technical Parameter

Model	YR01766	YR01767
Max weigh scope	120g	220g
Precision level	Ⓡ	
Weigh scope	0~120g	0~220g
value of scale division	0.0001g	
Standard weights value	100g	220g
Repeatable tolerance (standard tolerance)	±0.0003g	
Linear tolerance	±0.0003g	
Stable time	≈3s	
Pre-heat time	60-120 minutes	
Operation temperature	20±2.5°C	
Pan diameter	90mm	
Overall dimensions	325mmX205mmX305mm (L*W*H)	
Weigh chamber dimensions	180mmX175mmX200mm (L*W*H)	
Net weight	≈ 6kg	
Gross weight	≈8kg	
Adapter power supply	220V、50Hz, 15V/600mA	
Package size	460mmX360mmX400mm (L*W*H)	

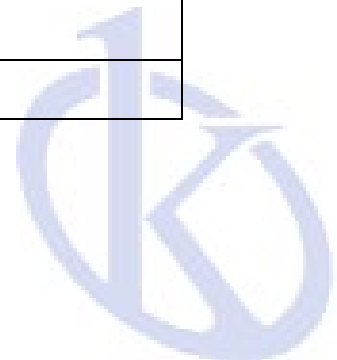





## Repair and Maintenance

### Repairing

Repairing must be done by the trained technicians.

### Cleaning

- ✧ Unplug the power adapter from the socket , if there is cable connecting with the balance interface , unplug the cable as well .
- ✧ Clean the balance by a cloth soaked in neutral flush (soap) .
- ✧ After cleaning, wipe the balance by a soft dry cloth .
- ✧ Taking up the bracket to check the weighing system not damaged.

Don't make the liquid flow into the shield of balance; Don't use the corrosive flush(solvent) to clean the stainless steel surface . All the stainless steel parts need to be flushed frequently , take out of all the stainless steel parts and flush them completely , use the wet cloth or sponge to clean the stainless steel parts . Only use the homely flush suitable to clean stainless steel parts .

### Warranty

Please do not ignore the warranty.

We offer one year warranty for the balance from the date it sold out, Damages not caused by misuse or vandalism all belong to warranty exclude the following case :

- ✧ Balance out of warranty .
- ✧ Damage caused by misuses such as long time under sunshine or receive corrosion .
- ✧ The user does not obey the operation manual such as overloading the balance .
- ✧ Without our authorized department or technician repairing, the user disassembly the balance on his own .
- ✧ Any brute force application caused the damage of balance . E.g. throw the heavy loads to the pan , open or shut the chamber door violently .

