



Model Series YR05698 to YR05700
Portable Pressure Steam Autoclave
Instruction Manual

Thank you very much for purchasing our Portable Pressure Steam Autoclave Model YR05698 to YR05700.

Please read the “Operating Instructions” and “Warranty” before operating this unit to assure proper operation. After reading these documents, be sure to store them securely together with the “Warranty” at a hand place for future reference.



Warning: Before operating the unit, be sure to read carefully and fully understand important warnings in the operating instructions.



OUR SERVICES

Benefits and Support

In Kalstein France, we take care of the full satisfaction of our customers, that is why we provide value-added services of the highest level based on our experience.



Online Inductions and Trainings

In any part of the world, receive your induction or training from our specialized team of engineers



Quick Response

Our work team is always available to response all your consults or questions, in order to support you in any situation.



#Letsgivemore

Thanks to your purchase, a donation will be made to a non-profit foundation that fights against breast cancer and helps most vulnerable communities.



Technical Support

Enjoy of personalized advice for the correct preventive and corrective maintenance of your equipment, thanks to Kalstein's manuals and articles, special catalogues and video tutorials.



Delivery Logistics

We take care of all the necessary logistics for the dispatch of your goods, whether is by sea, land or air.



Kalstein Worldwide

With more than 25 years growing with our customers, Kalstein's multiformat and modern content, is now present in more than 10 countries and increasing.





Warm Tips

1. Please read the instruction manual carefully before operating the equipment, and make the book well-kept, so that you can make reference to, and we can serve for you in the future.
2. We are not responsible for the damage and malfunction due to improper installation, operation, moving, and other contrived reasons.
3. If the safety valve doesn't vent even when pressure gauge pointer exceeds 0.165Mpa, stop using immediately and check its sensitivity. Don't strike the apparatus during using. Never use the machine under over-high-pressure condition; pressure gauge must be checked 1-2 times every year to ensure its accuracy.
4. The equipment should be kept clean and dry in ordinary times, pour water out of container when finishing using, to help to prolong the life of the sterilization machine.
5. Check the sealing ring to find whether abrasion or aging occurs, and change it timely, to ensure its sealing capacity.



Brief introduction

The sterilization machine we produce for objects disinfection and sterilization works through saturated high-pressured steam, it has following advantages of being easy to operate, heating up quickly, sterilizing thoroughly etc. It can be used in hospitals, academies of health, health care stations, infirmaries in mineral factories, laboratories, cosmetic factories, food factories, scientific research centers and so on. It can work on medical apparatus, dressing, glass utensils, solution, culture medium, etc. It can also be used as cook instrument in altiplano area.

Main body structure

1. Safety valve
2. Handle
3. Pressure gauge
4. Steam release valve
5. Container lid
6. Sealing washer
7. Butterfly nut
8. Bolt
9. Container
10. Sterilization pail
11. Sieve plate
12. Electric coil
13. Water discharge cock
14. Sterilization termination indicator
15. Pressure increasing indicator
16. Timer
17. Switch
18. Pressure adjuster
19. Wrench
20. Power plug

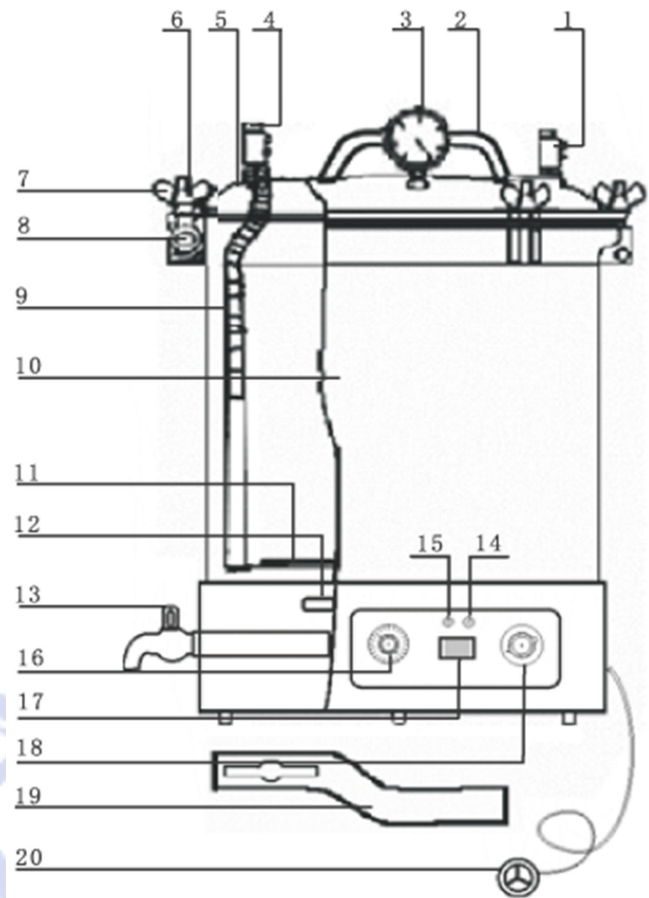

Structure characteristics

1. The main body of the container to our product is made of high-quality stainless steel 304 with one portion of Gr, eighteen of Ni, nine of Ti. Our product is not only acid-proof, alkali-proof, but also safe and durable to consume, its life is three times longer than aluminum metal alloy product.
2. Our product heated up by immersion heating element, consumes little power, while temperature goes up quickly.
3. Equipped with high-pressure faucet to drain water off, convenient and safely.



4. The safety valve can release over-high pressure automatically when the steam pressure exceeds 0.165MPa to ensure the safety.
5. The pressure gauge is designed to have double scales, with two types of reading to show pressure and temperature clearly.

Technique parameters

1. Capacity of disinfect cylinder: 30L
2. Working pressure rating: 0.14 - 0.16MPa
3. Maximal safety pressure: 0.165MPa
4. Power source pressure: 220V
5. Power of heating element: 2.0kw

Installation and debugging

1. Take out the product from the packing box properly.
2. The apparatus must be installed on flat surface; do not fix it using on unlevelled surface.
3. The left, right and back sides of the apparatus should be kept away from walls by 15cm at least.
4. To be sure the power source voltage is in accordance with the demand of the apparatus, and dependable earth wire required.
5. Don't locate the apparatus near inflammable gas sources; it should be installed in dry and ventilatory environment.



Operating instructions

1. Adding water: it can be used when 4.5L water has been added into the container, but the water level can't exceed the three-shelving plane which is under inner barrel. Water rating must be supply enough during circulative use, in order to prevent damaging the heating element due to water shortage.
2. Heating objects: put these objects needed to be sterilized on sieve plate, there should be gaps among these packed objects, to help steam to permeate and improve working quality.
3. Airproofing: put the sanitizing cylinder into the container, and then insert the soft tube which is on container lid into the semicircle groove in the cylinder, screw the container lid with wing-shaped nut in container tightly, make no distance between the lid and container.
4. Heating: connect the power source to power source; venting valve and safety valve should be raised when heating begins to make cold air in sanitizing cylinder go out; when temperature inside is more than 100°C, and when rapid steam jet out, restore the hats of the two valves to original.
5. Cooling: when finishing sterilizing, turn off power first, and then open the vapor valve and the lid when the reading of pressure gauge turns back to zero after cooling. Be cautious to not open valve to venting or open the lid as soon as finishing sanitizing, to avoid seething lotion overflowing which may cause accident.

Reference table of Time, pressure and temperature about vary material needed to be sterilized

Materials	Time needed (minute)	Steam pressure			Saturated steam relative temperature °C
		Mpa	kgN/cm ²	ponud/inch ²	
Rubber	15	0.11	1.1	16	121-126
Dressing	30-45	0.105-0.14	1.05-1.4	15-20	121-126
Utensil	15	0.105-0.14	1.05-1.4	15-20	121-126
Instrument	10	0.105-0.14	1.05-1.4	15-20	121-126
Liquor in bottle	20-40	0.105-0.14	1.05-1.4	15-20	121-126



Technical Specifications

Model	YR05698	YR05699	YR05700
Capacity	18 L	24 L	30 L
Size	Φ300*330mm	Φ300*460mm	Φ300*520mm
Max Working Pressure		0.165Mpa	
Working pressure		0.14-0.16Mpa	
Working Temperature		115-129°C	
Timer		0-80 min	
Power		2KW	

